

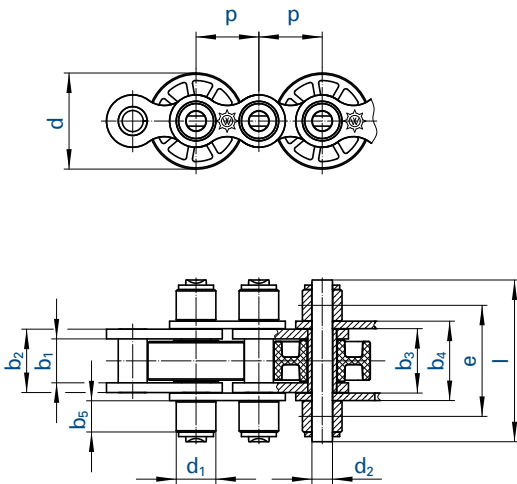

Design E

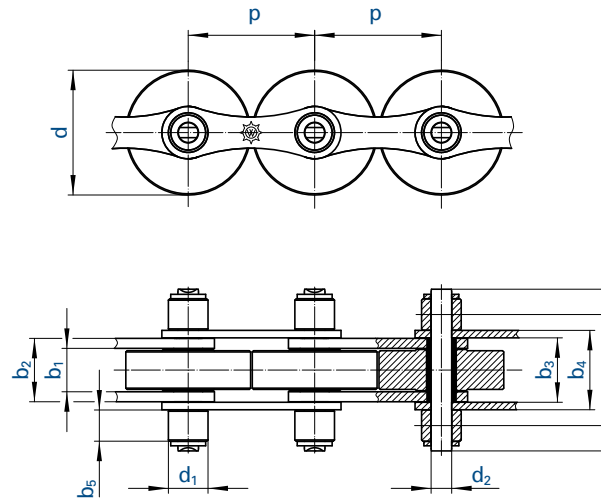

Double pitch chain Design L



Chain	Pitch	Design	Inner width	Inner link width	Width		Support roller Ø	Pin Ø	Transverse pitch	Plate height	Width over pin	Support roller width	Width over pin Type I	Support roller width	
					between outer plates	over outer plates									
	p		b ₁ min.	b ₂ max.	b ₃ min.	b ₄ max.	d ₁	d ₂ max.	e	g max.	l max.	b ₅ max.	l max.	b ₅ max.	
No.	Ind.	mm	mm	mm	mm	mm	mm	mm	mm	mm	mm	mm	mm	mm	
513 SF MA		19,05	E	11,68	15,62	15,80	20,0	12,00	5,72	31,50	16,1	48,0	11,5	43,0	9,0
548 SF MA		25,40	E	17,02	25,45	25,81	32,0	15,88	8,28	44,50	21,0	65,0	12,5	-	-
722 SF MA		38,10	L	11,68	15,62	15,80	20,0	12,00	5,72	31,50	16,1	48,0	11,5	-	-
728 SF MA		50,80	L	17,02	25,45	25,81	32,0	15,88	8,28	44,50	21,0	65,0	12,5	-	-
D 513 SF MA		19,05	D	11,68	15,62	15,80	20,0	12,07	5,72	52,00	16,1	68,0	11,5	-	-
D 548 SF MA		25,40	D	17,02	25,45	25,81	32,0	15,88	8,28	76,76	21,0	97,0	12,5	-	-
T 513 SF MA		19,05	T	11,68	15,62	15,80	20,0	12,07	5,72	38,92	16,1	61,7	-	-	-
T 548 SF MA		25,40	T	17,02	25,45	25,81	32,0	15,88	8,28	63,76	21,0	99,9	-	-	-

Sprockets are available for all accumulator chains!

Connecting links with securing circlips.

Our connecting links always have the same length l as the ordinary pins.

Temperature range: - 30 to 100°C for steel conveyor rollers

- 10 to 60°C for plastic conveyor rollers

For information on AFS clips for optimal equipment and finger protection see page 60.



Design D

Design T

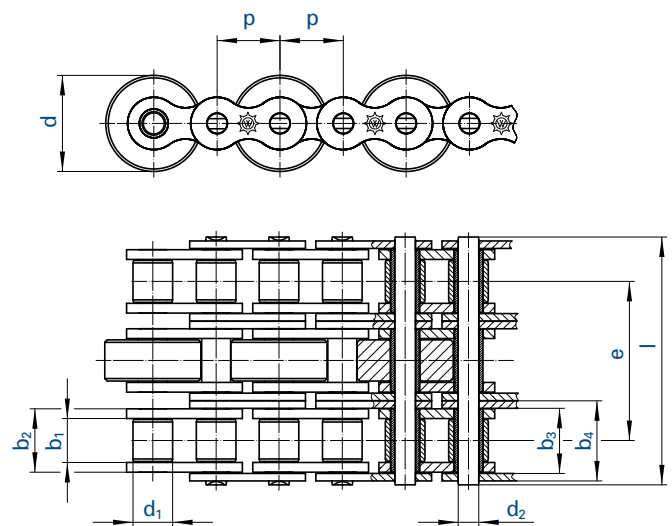
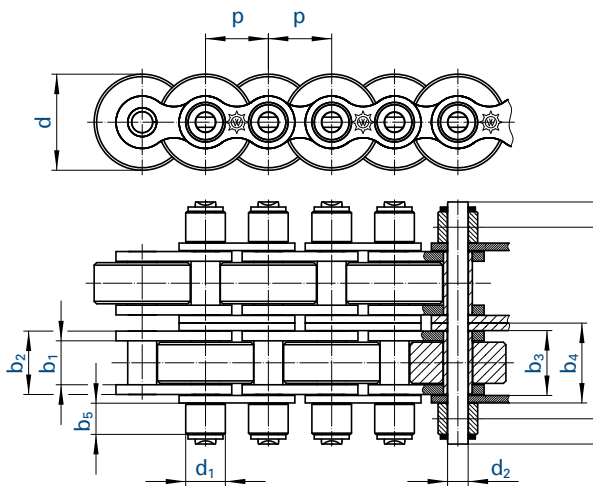

Width over pin Type II	Support roller width	Conveyor rollers						Breaking load ⚙️ FB min.	Maximum load per m conveyor chain with 10 m conveyor length	
		Designation for material			Diameter				Steel	Plastic
l max.	b5 max.	Steel	PA 6.6	Vestamide	d	Type I d	Type II d			
mm.	mm				mm	mm	mm	kN	kg	kg
40,0	7,5	SF	SFK	SFV	24,0	26,0	28,0	29,0	300	260
-	-	SF	SFK	SFV	38,5	-	-	60,0	600	500
-	-	SF	SFK	SFV	24,0	26,0	28,0	29,0	300	260
-	-	SF	SFK	SFV	38,5	40,0	50,0	60,0	600	500
-	-	SF	SFK	SFV	24,0	26,0	28,0	57,8	600	520
-	-	SF	SFK	SFV	38,5	-	-	120,0	1200	1000
-	-	SF	SFK	SFV	24,0	26,0	28,0	60,0	600	260
-	-	SF	SFK	SFV	38,5	-	-	120,0	1200	500

The load per m applies for 10 m conveyor length per double chain strand. The load may be proportionally increased for shorter chain lengths and must be proportionally decreased for longer conveyor distances: e.g. 5 m conveyor distance = double load, 20 m conveyor distance = half load.

Maximum conveyor distances 25 - 30 m. The installation of guide plates is recommended as of 15 m.