

Klinkenzüge

Latch locks

Ouvres-moules

DLC 

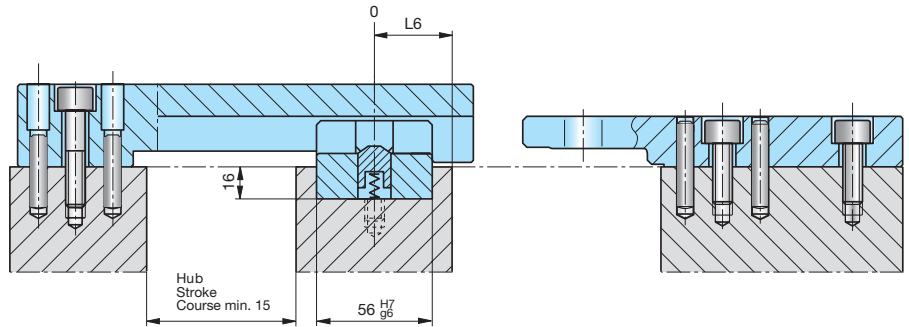
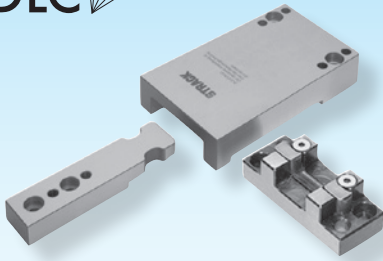

Z4-30-

i deutsch 6.84-94
english 6.95-105
français 6.106-116

 Z4-30-L1-
L3-L4-L5-L6



6

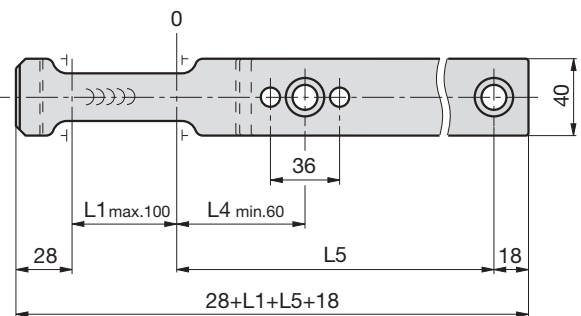
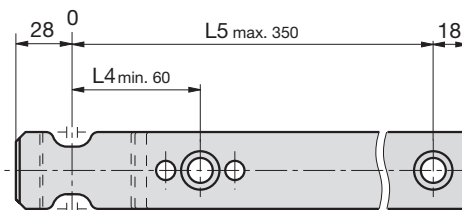
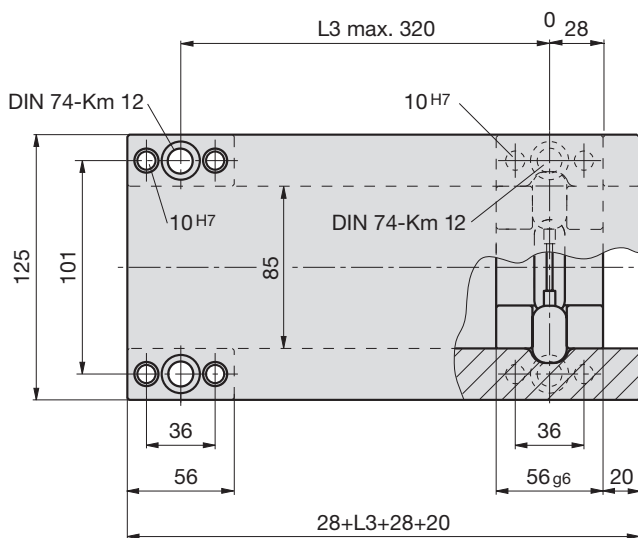
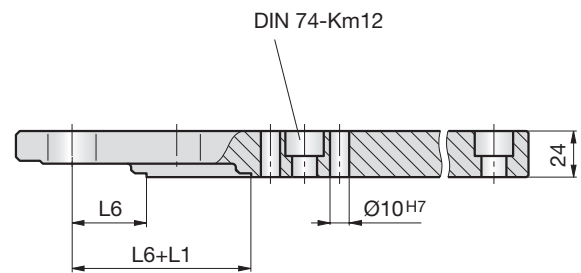
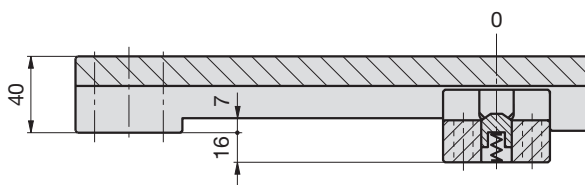

Klinkenzüge		Latch locks		Ouvres-moules	
Z4-30-	deutsch 6.84-94 english 6.95-105 français 6.106-116				
 Z4-30-L1- L3-L4-L5-L6					
Z4-32-	deutsch 6.84-94 english 6.95-105 français 6.106-116				
 Z4-32-L3-L5					

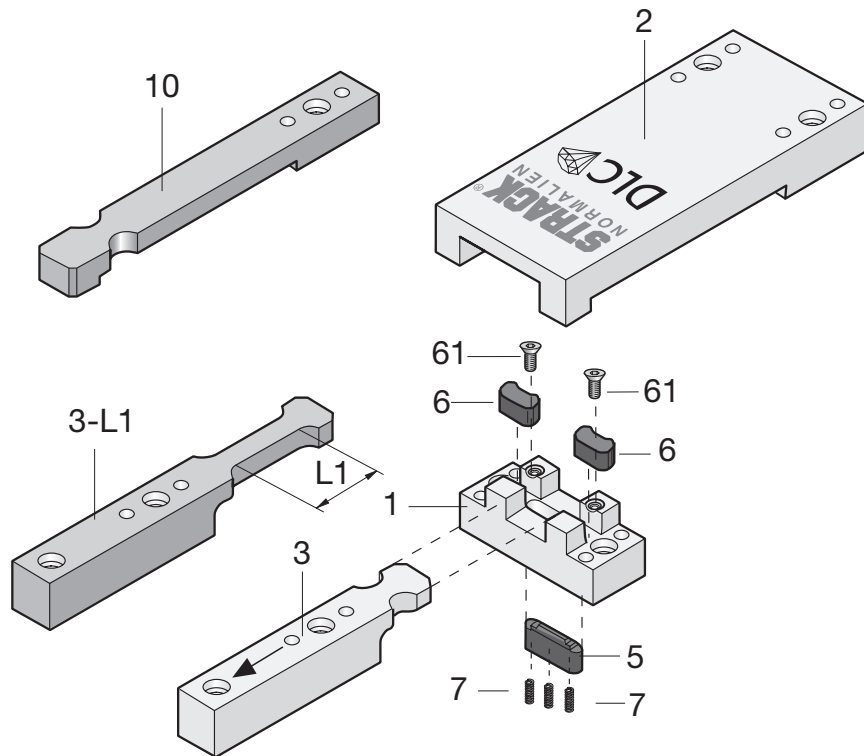

Stückliste

Parts list

Liste des pièces



Z4-30-Type / Z4-32-Type

Type	Pos. Item Pos.	Bezeichnung	Description	Désignation	Stück Quant. Nbr.	Mat.-Nr. Mat.-No Mat.Nr.
01	1	Klinkengehäuse	Latch housing	Support mobile	1	
02	2	Steuerplatte	Control plate	Plaque support	1	1.2162 ¹⁾
03	3	Zugleiste	Latch bar	Crochet	1	1.2162 ¹⁾
03 L1	3-L1	Zugleiste mit Verzögerung L1 = max. 100 mm	Latch bar with delay L1 = max. 100 mm	Crochet de traction à retardement L1 = max. 100 mm	1	1.2162 ¹⁾
05	5	Sperre	Catch stop	Verrou	1	DLC
06	6	Raste	Catch	Clavette	2	DLC
10	10	Ausstoßerleiste	Reverse latch bar	Poussoir	1	1.2162 ¹⁾

¹⁾ ~ 630 HV10
Einatzhärtetiefe (Eht)
Thickness of hardened layer = 0,4 - 0,6 mm
Épaisseur de la couche durcie

Normalien

Standard parts

Elements standard



Strack Norm

Strack Norm	Pos. Item Pos.	Stück Quant. Nbr.	Bezeichnung	Description	Désignation	Mat.-Nr. Mat.-No Mat.Nr.
SN3550-M5-10	61	2	Senkschraube	Countersunk screw	Vis à tête fraisée	SN
SN2500-5-15	7	3	Druckfeder	Spring	Ressort de pression du verrou	SN

Lieferumfang

Scope of delivery

Contenu de la livraison

Z4-30-0	Z4-30-L1	Z4-32
01	01	01
02	02	02
03	03-L1	
05	05	
06 + 061	06 + 061	06 + 061
07	07	
		10

Achtung!
Bei einer Ersatzbestellung der Positionen 2, 3, 3-L1 und 10 erfolgt eine Lieferung ohne Befestigungsbohrungen.

Warning!
If items 2, 3, 3-L1 or 10 are ordered as spare parts, they will be supplied without fixing holes.

Attention!
A la commande de pièces de rechange pour les réf. 2, 3, 3-L1 et 10 la livraison sera effectuée sans alésages de fixation.