

## Gasdruckfedern

## Gas springs

## Ressorts à gaz

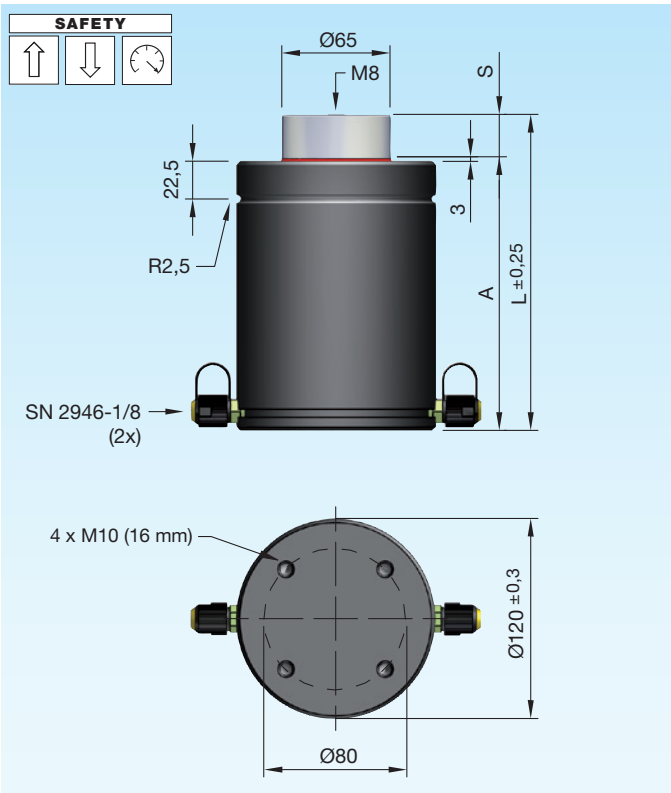

### Einbauvarianten / Installation variants / Variantes de montage

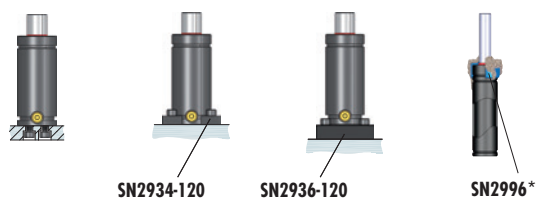

Druckmedium	Pressure medium	Médium de pression	<b>Stickstoff (N<sub>2</sub>)</b>
Max. Fülldruck	Max. filling pressure	Pression de rempl. max.	<b>150 bar</b>
Min. Fülldruck	Min. filling pressure	Pression de rempl. min.	<b>35 bar</b>
Max. Betriebs-temperatur	Max. working temperature	Température de service max.	<b>80 °C</b>
Temperaturabhängige Druckerhöhung	Pressure increase due to temperature	Accroissement de pression sous l'influence de la temp.	<b>0,33 %/1 °C</b>
Instandhaltungsset	Maintenance kit	Jeu de maintenance	<b>SN2990-SC5000</b>
Max. Kolben-geschwindigkeit	Max. piston speed	Vitesse max. du piston	<b>1,6 m/s</b>

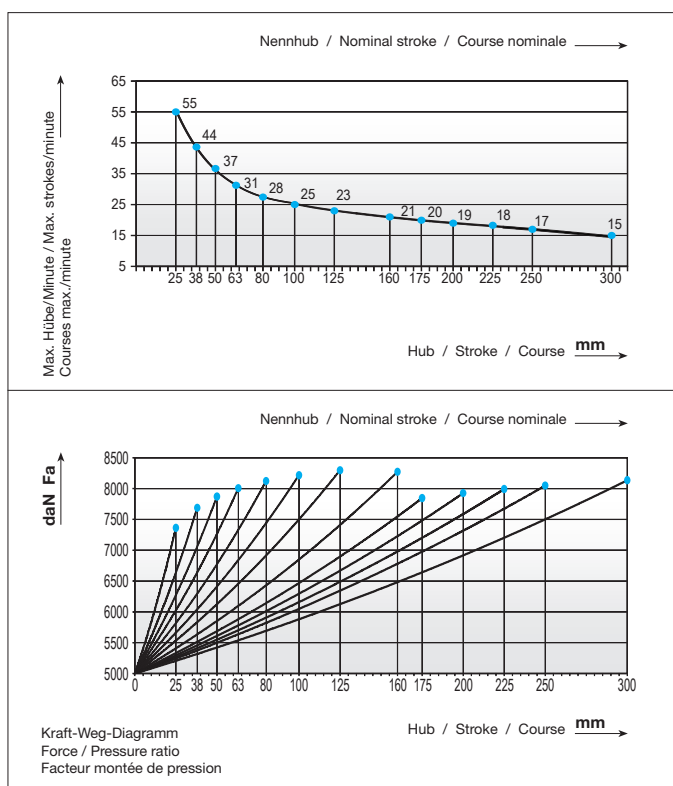

SN2820-C-5000-	~ISO 11901-1 ~VDI 3003	S	daN	daN	bar	A	L	V [l]	Fa [cm <sup>2</sup> ]	kg
SN2820-C-5000-S		25	5000	7330	150	165	190	0,258	33,18	12,01
		38	(±5%)	7655	150	178	216	0,361	33,18	12,85
		50		7835	150	190	240	0,455	33,18	13,60
		63		7970	150	204	267	0,557	33,18	14,50
		80		8085	150	220	300	0,690	33,18	15,39
		100		8180	150	240	340	0,847	33,18	16,48
		125		8260	150	265	390	1,044	33,18	18,05
		160		8235	150	300	460	1,342	33,18	19,83
		175		7810	150	315	490	1,601	33,18	20,11
		200		7890	150	340	540	1,798	33,18	21,70
		225		7955	150	365	590	1,994	33,18	22,60
		250		8010	150	390	640	2,191	33,18	23,85
		300		8100	150	440	740	2,583	33,18	25,60

S = Hub / Stroke / Course

bar = Fülldruck / Filling pressure / Pression de remplissage

\* i SN2996 = Seite / Page 2.3.254