

## Gasdruckfedern

## Gas springs

## Ressorts à gaz

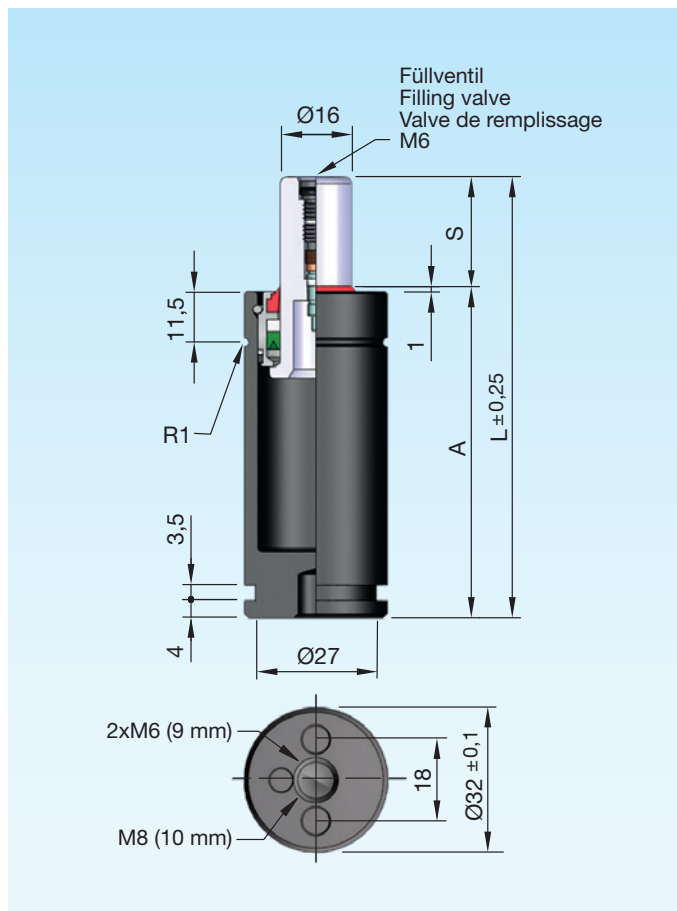

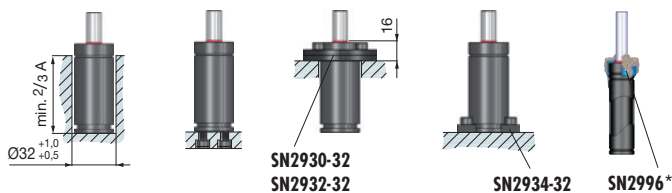

### Einbauvarianten / Installation variants / Variantes de montage

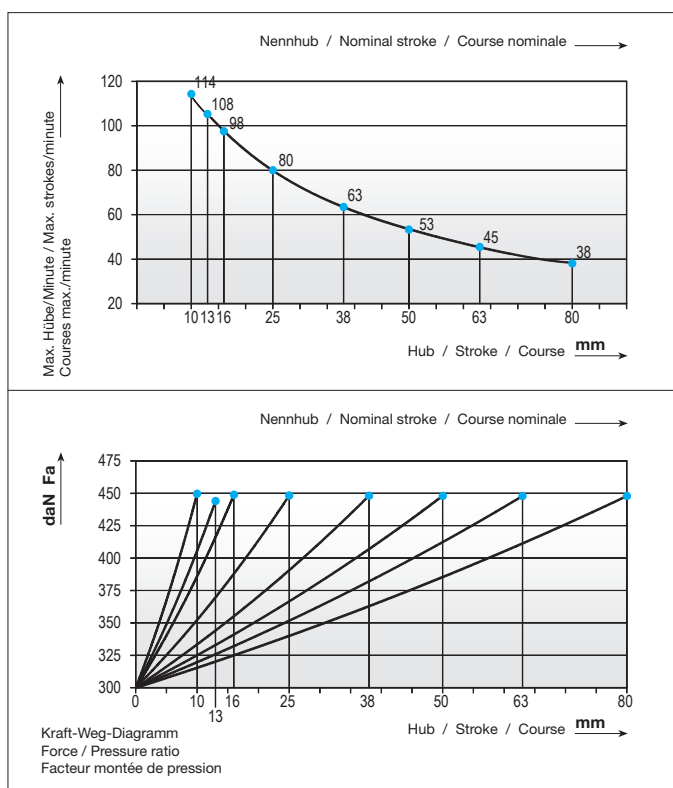

|                                   |                                      |  |                                   |
|-----------------------------------|--------------------------------------|--|-----------------------------------|
| Druckmedium                       | Pressure medium                      | Médium de pression                                     | <b>Stickstoff (N<sub>2</sub>)</b> |
| Max. Fülldruck                    | Max. filling pressure                | Pression de rempl. max.                                | <b>150 bar</b>                    |
| Min. Fülldruck                    | Min. filling pressure                | Pression de rempl. min.                                | <b>25 bar</b>                     |
| Max. Betriebs-temperatur          | Max. working temperature             | Température de service max.                            | <b>80 °C</b>                      |
| Temperaturabhängige Druckerhöhung | Pressure increase due to temperature | Accroissement de pression sous l'influence de la temp. | <b>0,33 %/1 °C</b>                |
| Instandhaltungsset                | Maintenance kit                      | Jeu de maintenance                                     | <b>SN2990-SP300</b>               |
| Max. Kolben-geschwindigkeit       | Max. piston speed                    | Vitesse max. du piston                                 | <b>1,6 m/s</b>                    |



| SN2820-P-300-  | ~ISO 11901-1<br>~VDI 3003   | S  | daN   | daN | bar | A    | L    | V [l] | Fa [cm <sup>2</sup> ] | kg   |
|--|---|----|-------|-----|-----|------|------|-------|-----------------------|------|
|  SN2820-P-300-S |   | 10 | 300   | 450 | 150 | 60   | 70   | 0,006 | 2,01                  | 0,31 |
|  |   | 13 | (±5%) | 445 | 150 | 62,7 | 75,4 | 0,008 | 2,01                  | 0,33 |
|  |   | 16 |       | 450 | 150 | 66   | 82   | 0,010 | 2,01                  | 0,34 |
|  |   | 25 |       | 450 | 150 | 75   | 100  | 0,015 | 2,01                  | 0,38 |
|  |   | 38 |       | 450 | 150 | 88   | 126  | 0,023 | 2,01                  | 0,43 |
|  |   | 50 |       | 450 | 150 | 100  | 150  | 0,030 | 2,01                  | 0,48 |
|  |   | 63 |       | 450 | 150 | 113  | 176  | 0,038 | 2,01                  | 0,53 |
|  |   | 80 |       | 450 | 150 | 130  | 210  | 0,049 | 2,01                  | 0,61 |
|  |   |    |       |     |     |      |      |       |                       |      |
|  |   |    |       |     |     |      |      |       |                       |      |
|  |   |    |       |     |     |      |      |       |                       |      |

S = Hub / Stroke / Course

bar = Fülldruck / Filling pressure / Pression de remplissage

\*  SN2996 = Seite / Page 2.3.254