

Gasdruckfedern mit vermindertem Druckanstieg

Gas springs with reduced pressure increase

Ressorts à gaz avec une augmentation de pression réduite

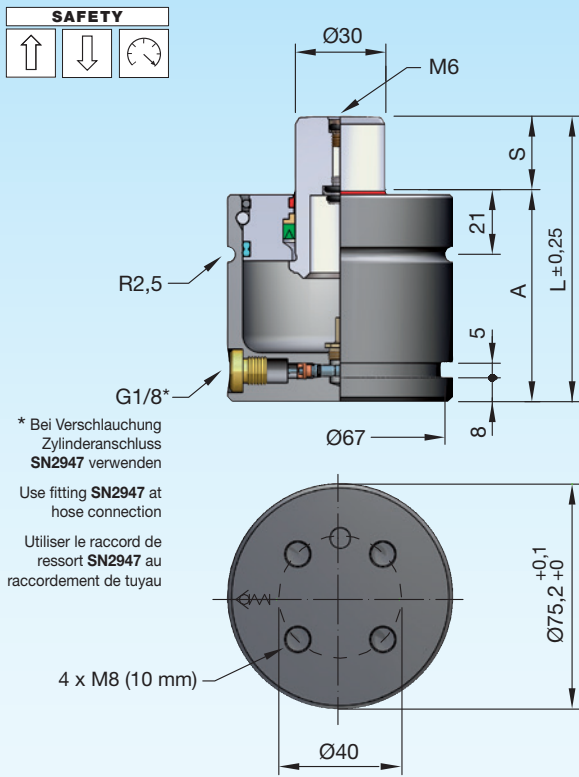

Druckmedium	Pressure medium	Médium de pression	Stickstoff (N₂)
Max. Fülldruck	Max. filling pressure	Pression de rempl. max.	175 bar
Min. Fülldruck	Min. filling pressure	Pression de rempl. min.	35 bar
Max. Betriebs-temperatur	Max. working temperature	Température de service max.	80 °C
Temperaturabhängige Druckerhöhung	Pressure increase due to temperature	Accroissement de pression sous l'influence de la temp.	0,33 %/1 °C
Instandhaltungsset	Maintenance kit	Jeu de maintenance	SN2990-B1250
Max. Kolben-geschwindigkeit	Max. piston speed	Vitesse max. du piston	1,2 m/s

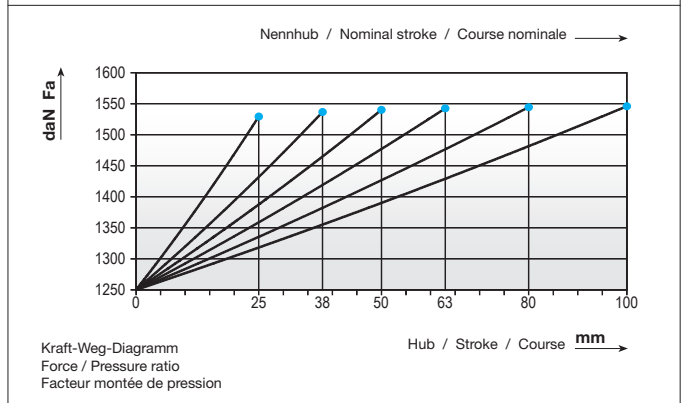
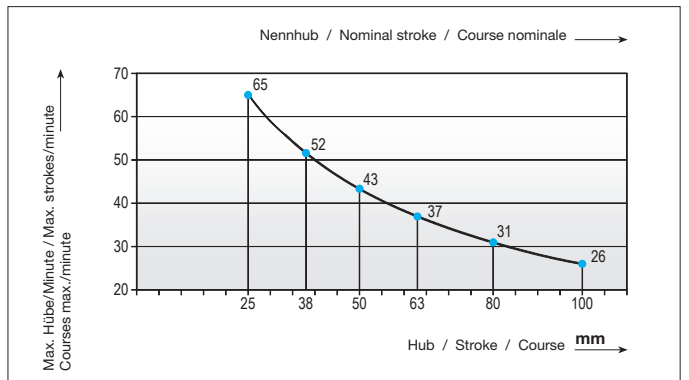

Einbauvarianten / Installation variants / Variantes de montage

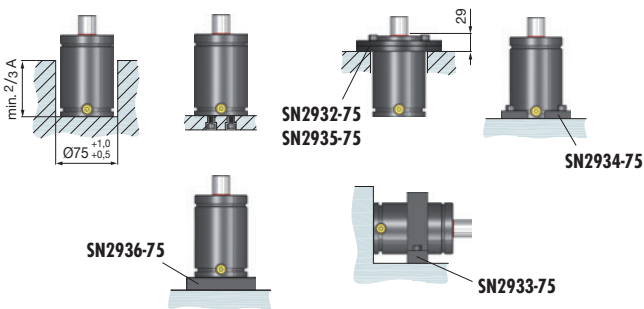

SN2825-1250-



SN2825-1250-S



S = Hub / Stroke / Course

bar = Fülldruck / Filling pressure /
 Pression de remplissage

S	daN	daN	bar	A	L	V [l]	Fa [cm ²]	kg
25	1250	1540	175	70	95	0,097	7,07	1,30
38	(±5%)	1545	175	83	121	0,144	7,07	1,51
50		1545	175	95	145	0,188	7,07	1,58
63		1550	175	108	171	0,235	7,07	1,67
80		1550	175	125	205	0,297	7,07	2,08
100		1550	175	145	245	0,369	7,07	2,49