

Gasdruckfedern MICROserie

Gas springs MICROseries

Ressorts à gaz MICROsérie

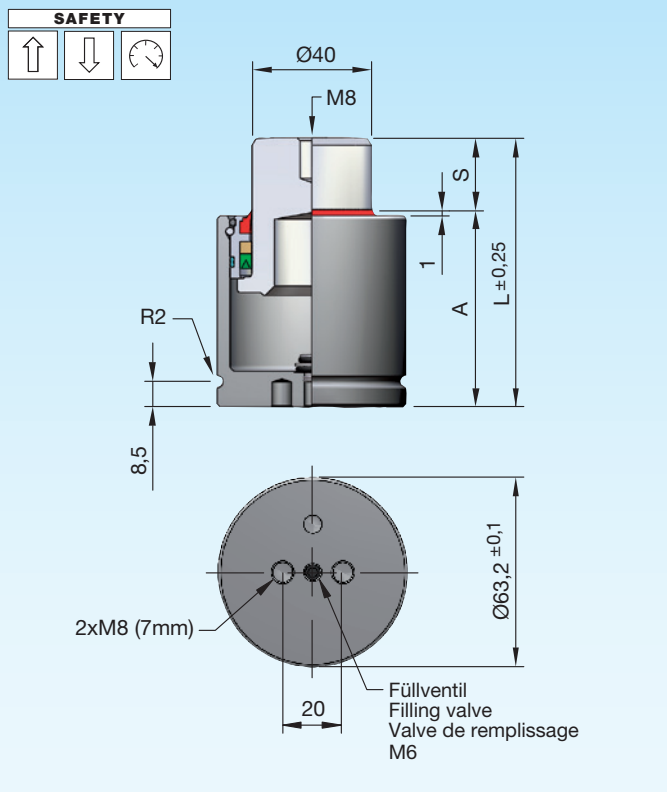

Druckmedium	Pressure medium	Médium de pression	Stickstoff (N ₂)
Max. Fülldruck	Max. filling pressure	Pression de rempl. max.	150 bar
Min. Fülldruck	Min. filling pressure	Pression de rempl. min.	35 bar
Max. Betriebs-temperatur	Max. working temperature	Température de service max.	80 °C
Temperaturabhängige Druckerhöhung	Pressure increase due to temperature	Accroissement de pression sous l'influence de la temp.	0,33 %/1 °C
Instandhaltungsset	Maintenance kit	Jeu de maintenance	SN2990-M63
Max. Kolben-geschwindigkeit	Max. piston speed	Vitesse max. du piston	0,6 m/s

3

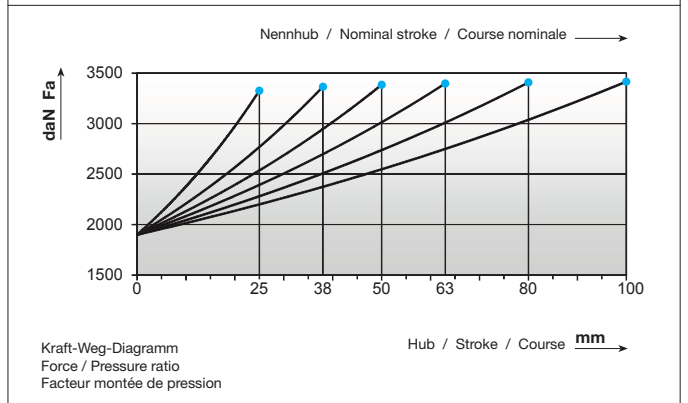
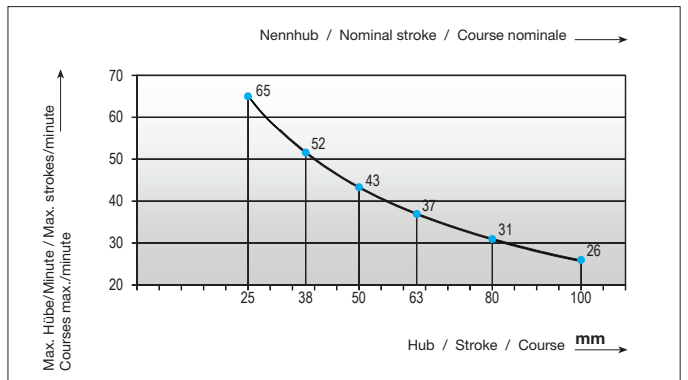

Einbauvarianten / Installation variants / Variantes de montage

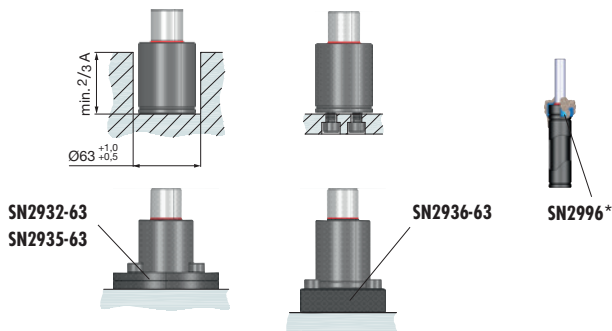

SN2808-1900-



SN2808-1900-S



S = Hub / Stroke / Course

bar = Fülldruck / Filling pressure /
Pression de remplissage

* i SN2996 = Seite / Page 2.3.254

S	daN	daN	bar	A	L	V [l]	Fa [cm ²]	kg
25	1900	3300	150	65	90	0,073	12,57	0,93
38	(±5%)	3340	150	78	116	0,110	12,57	1,39
50		3360	150	90	140	0,143	12,57	1,65
63		3370	150	103	166	0,180	12,57	1,81
80		3380	150	120	200	0,227	12,57	1,90
100		3390	150	140	240	0,283	12,57	2,23

D 3002A 07.2018