

### Gasdruckfedern kleine Abmessungen

### Gas springs small dimensions

### Ressorts à gaz dimensions petites

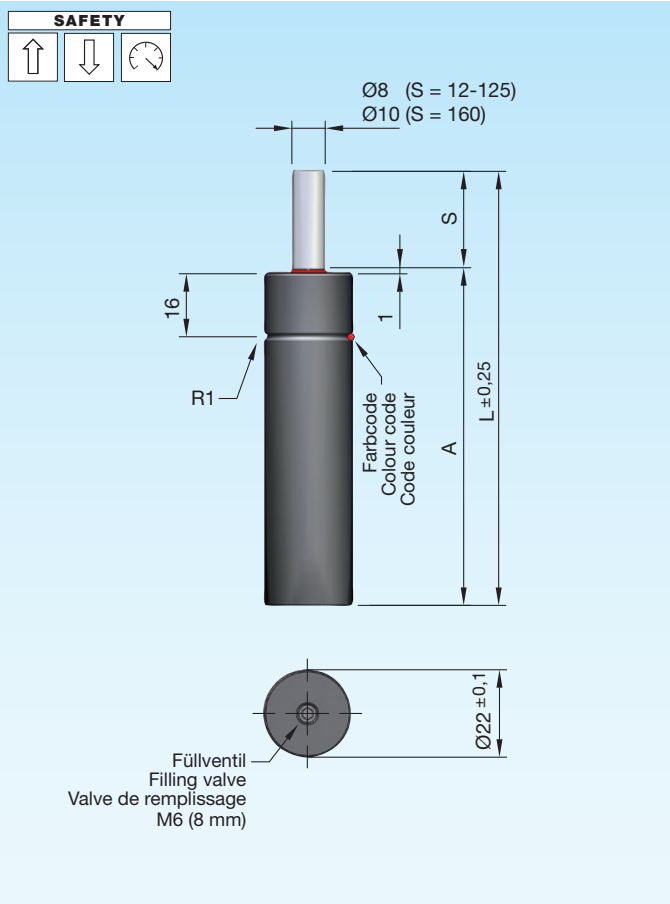

Druckmedium	Pressure medium	Médium de pression	<b>Stickstoff (N<sub>2</sub>)</b>
Max. Fülldruck	Max. filling pressure	Pression de rempl. max.	<b>175 bar</b>
Min. Fülldruck	Min. filling pressure	Pression de rempl. min.	<b>50 bar</b>
Max. Betriebs-temperatur	Max. working temperature	Température de service max.	<b>80 °C</b>
Temperaturabhängige Druckerhöhung	Pressure increase due to temperature	Accroissement de pression sous l'influence de la temp.	<b>0,33 %/1 °C</b>
Instandhaltungsset	Maintenance kit	Jeu de maintenance	<b>SN2990-G22</b>
Max. Kolben-geschwindigkeit	Max. piston speed	Vitesse max. du piston	<b>1,6 m/s</b>

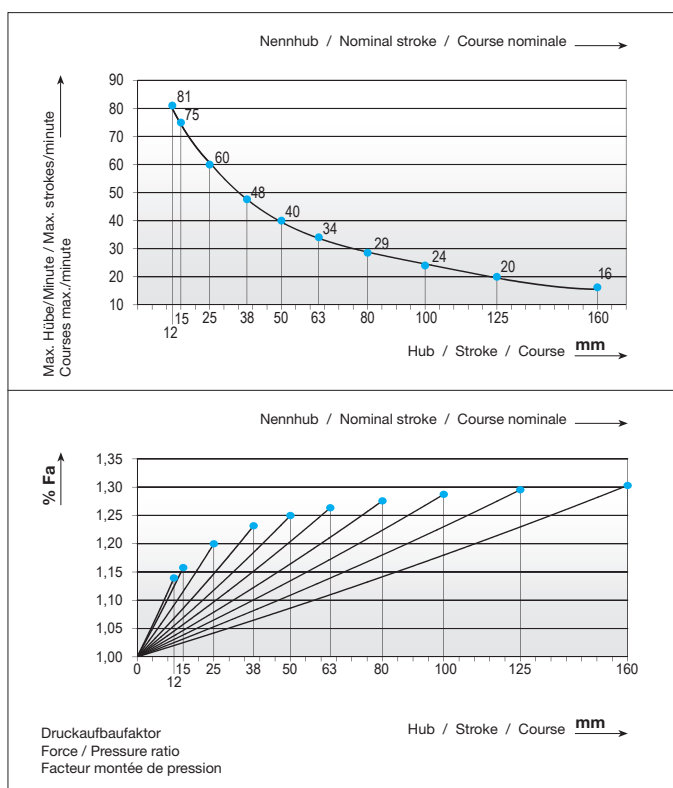

### Einbauvarianten / Installation variants / Variantes de montage

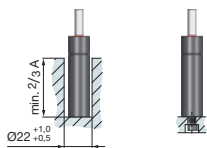

SN2805-90-		S	Type	A	L	V [l]	Fa [cm <sup>2</sup> ]	kg
<b>SN2805-90-S-Type</b>		12	1	72	84	0,005	0,50	0,23
		15	2	75	90	0,006	0,50	0,24
		25	3	85	110	0,008	0,50	0,27
		38	4	98	136	0,010	0,50	0,29
		50		110	160	0,013	0,50	0,32
		63		123	186	0,015	0,50	0,36
		80		140	220	0,019	0,50	0,38
		100		160	260	0,023	0,50	0,44
		125		185	310	0,028	0,50	0,46
		160		220	380	0,035	0,78	0,52
Type	Farbcode / Colour code / Code couleur	daN	daN	bar				
1	Grün / Green / Vert	30 (+5)	38	60				
2	Blau / Blue / Bleu	50 (+5)	65	100				
3	Rot / Red / Rouge	70 (+5)	90	140				
4	Gelb / Yellow / Jaune	90 (+5)	116	175				
Andere Kräfte / Other forces / Autres forces		25-90	≈32-116	50-175				

D 3002A 07.2018