

OVERALL DIMENSIONS

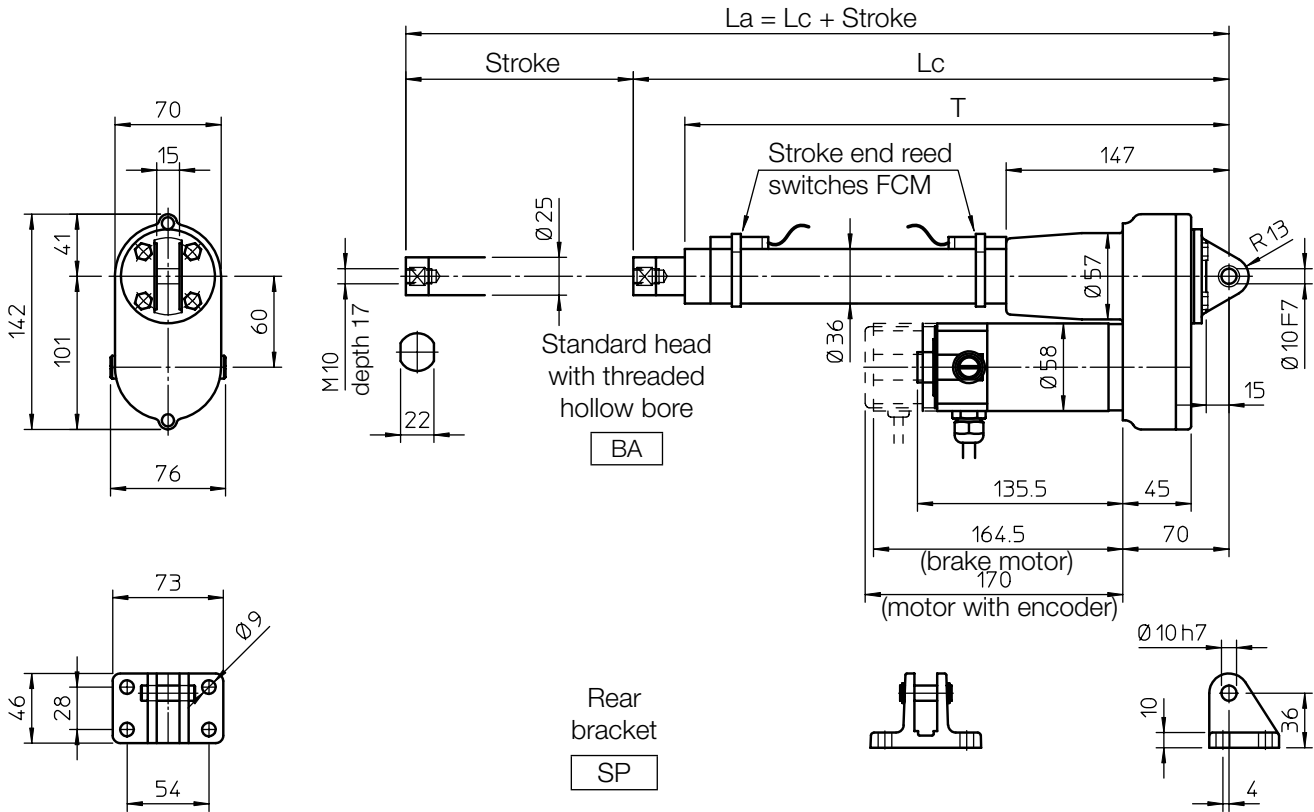

Length [mm]	Actuator
Lc	281 + Stroke
T	249 + Stroke

STROKE [mm]	LENGTH		T [mm]	MASS [Kg]	
	Lc [mm]	La [mm]		standard motor	brake motor
100	381	481	349	3.7	4.2
200	481	681	449	4.0	4.5
300	581	881	549	4.3	4.8
400	681	1081	649	4.7	5.2
500	781	1281	749	5.0	5.5

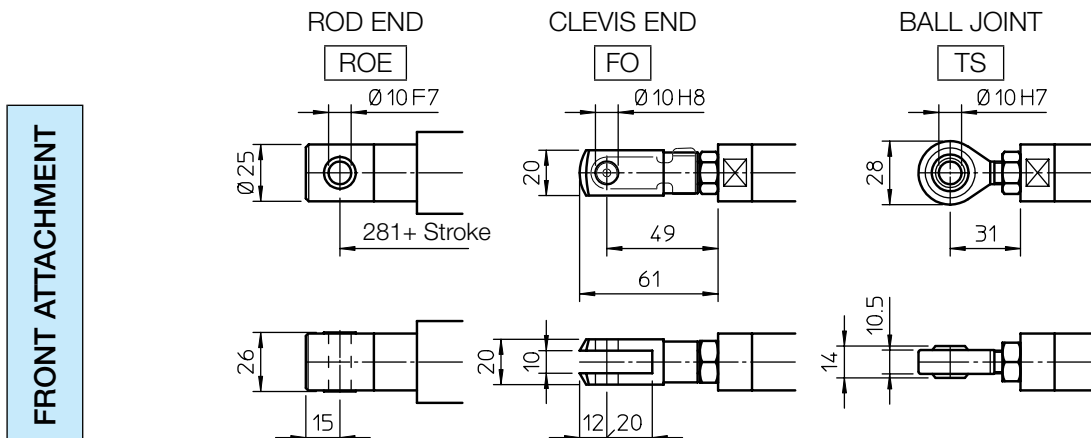

PERFORMANCES AND FEATURES

- Push-Pull load up to 420 N
- Linear speed up to 500 mm/s
- Standard stroke lengths:
100, 200, 300, 400, 500 mm
(for different / longer stroke lengths please contact us)
- Ball screw BS 14 x 5 or BS 14 x 10
(technical details on page 66)
- Aluminium alloy housing and rear attachment with bronze bush
- Anodized aluminium outer tube
- Chrome-plated steel push rod – tolerance f7
- Standard head BA or rod end ROE in stainless steel AISI 303 with bronze bush
- 12 or 24 V DC motor
(motor features details on page 69)
- Duty cycle with max load:
100% over 10 min at (-10 ... +40) °C
- Standard protection IP 54
- Long-life lubrication, maintenance free

ACCESSORIES

- Different front attachments
- Stainless steel push rod (code SS)
- Rear bracket (code SP)
- Two adjustable stroke end reed switches (code FCM)
- Extra switch for intermediate position
- Bi-directional incremental encoder, 100 ppr with zero set pulse, Push-Pull, 8÷24 Vcc (code EH38)
(encoder features details on page 75)

OPTIONS

- Fixing attachment turned at 90° (code RPT 90)

PERFORMANCES with 24 V DC motor

(Performances with 12 V DC motor: same load, linear speed 10 % less, electrical consumption 2 times more)

Ball screw BS 14 x 5			
RATIO	LOAD [N]	SPEED [mm/s]	CURRENT [A]
RV1	210	250	4
RN1	420	125	4

Ball screw BS 14 x 10			
RATIO	LOAD [N]	SPEED [mm/s]	CURRENT [A]
RV2	110	500	4
RN2	220	250	4

Self-locking conditions

Self-locking condition is achievable with brake motor only.

Information about statically self-locking conditions with pull or push load on page 68.

ORDERING CODE EXAMPLE

UBA 0	RN1	C200	CC 24 V	FCM					
Actuator	Selected ratio	Required stroke	Motor	Stroke end switches	Accessories			Options	

GENERAL NOTE

In case the linear actuator is used in an application where the stroke end switches must be connected to PLC or PC, we suggest to make the connection with a galvanic separation circuit.

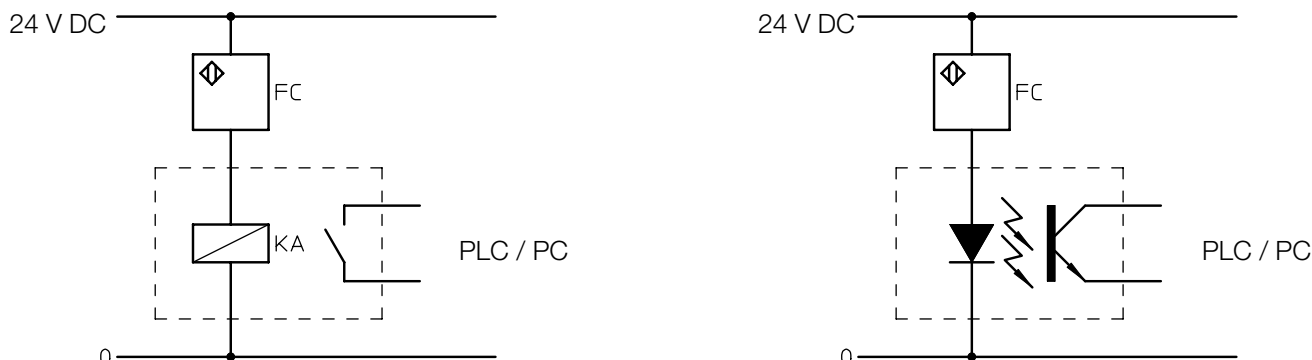

13.1 Magnetic stroke end switches (reed) FCM (linear actuators ATL, BSA, UAL, UBA Series, LMI 02 and LMP 03)

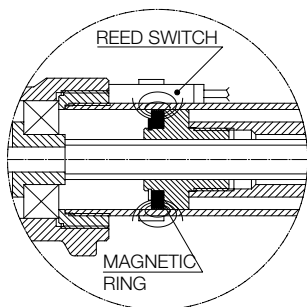

The magnetic field of the ring fixed on the nut activates the reed contact of the switch locked on the protective tube with a clamp.

The position of the switches along the tube is easily adjustable.

The switches used to determine any intermediate position (between L_c and L_a) will switch over in two different positions, depending on the push rod motion direction (extending or retracting).

WARNING! The magnetic reed-switches can work only if connected to a wiring control circuit in order to activate the electric relay. Do not connect them in series between the power supply and the electric motor!

REED CONTACT RATED VALUE

	DC	AC
Rated voltage	(3 ... 130) V	(3 ... 130) V
Max. commutable power	20 W	20 VA
Max. commutable current	300 mA (resistive load)	
Max. inductive load	3 W	

Standard: NC switch (normally closed contact) equipped with signalling LEDs and protective varistor against voltage peaks.

Standard cable length 2 m; wires 2 × 0.75 mm²

Different configurations available on request: NO (normally open); CS (exchanging contact).

For more information please contact our Technical Dpt.

13.2 Electric stroke end switches FCE (actuators ATL 10, ATL 12, BSA 10, BSA 12)

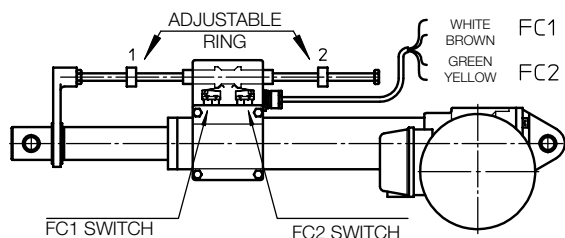

Two electric switches, installed inside a sealed plastic box, are activated by two adjustable rings through a shaft collar.

Standard switches are wired on the NC contact, cable length 1.5 m; wires 4 × 0.75 mm²

On request, they can be wired on the NO contact or on the switch-over contact CS (for available configurations please contact our Technical Dpt).

Min retracted length L_c is adjusted by ring 1. FC1 switch is connected with the WHITE and the BROWN cables.

Max extended length L_a is adjusted by ring 2. FC2 switch is connected with the YELLOW and the GREEN cables.

The position of the brass rings along the stainless steel supporting rod is easily adjustable.

CONTACT RATED VALUE

Voltage	Max current	
	Resistive load	Inductive load
250 Vac	5 A	3 A
30 Vdc	5 A	0.1 A
125 Vdc	1.4 A	-

WARNING! The electric reed switches can work only if connected to a wiring control circuit in order to activate the electric relay. Do not connect them in series between the power supply and the electric motor!

13.5 Encoder GI (linear actuators LMR 01, LMR02, LMR 03 and LMP03)

Hall effect, bi-directional, incremental encoder

Output configuration: PUSH-PULL

Code GI 21: 2 output channels, 1 pulse per revolution

Code GI 24: 2 output channels, 4 pulses per revolution

Cable length: as motor cable

Protected against polarity inversion

Protected against any incorrect output connection

NOTE: For conductive cables colour, please refer to the wiring diagram in the “Installation Instructions” supplied with the product.

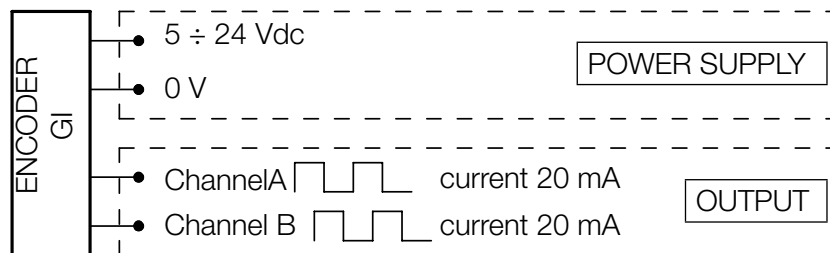

13.6 Encoder EH38 (linear actuators ATL 10, UAL 0, BSA 10, UBA 0)

Bi-directional, incremental, optical encoder

Output configuration: PUSH-PULL

Code EH38: 2 output channels, 100 pulses per revolution, with zero set pulse

Cable length: 1.3 m

Protected against short circuit

Protected against polarity inversion

Protected against any incorrect output connection

Input voltage: 8÷24 Vcc

No load power consumption: 100 mA

Max. commutable current: 50 mA per channel

NOTE: Safety clutch FS cannot be used with rotative encoder (the position reference would be lost due to its slipping).

