

Außenansicht (M1:50)

Vertikalschnitt (M1:50)

Montagesituationen im Sturz (M1:10)

a) Vor bzw. hinter der Leibung VL/HL

b) In der Leibung IL

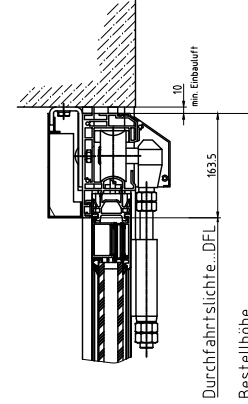
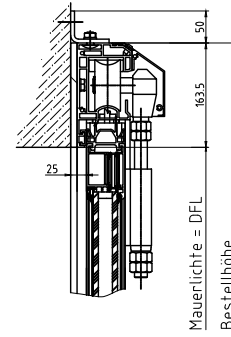
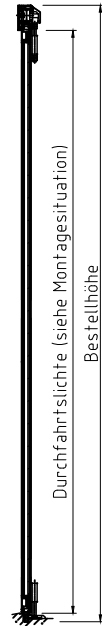
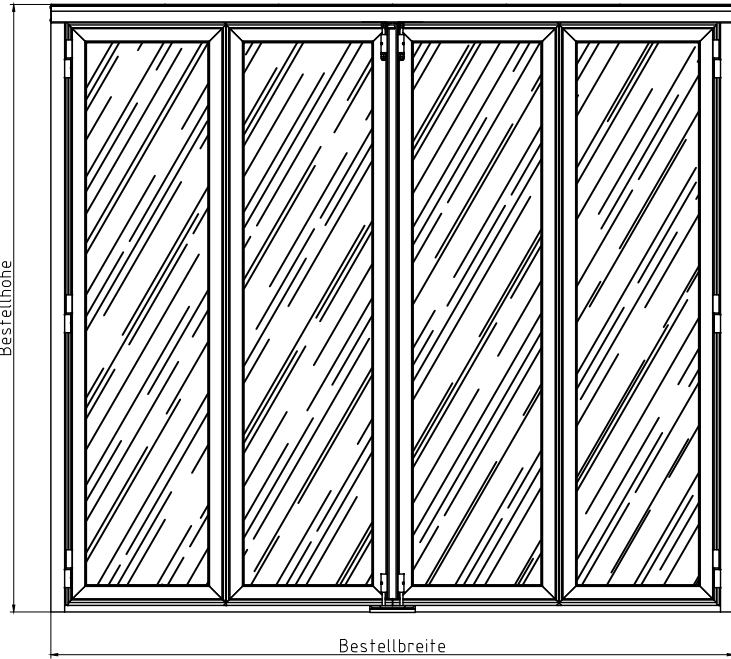

Bodendetails (M1:10)

a) Schwelle 55

b) Schwelle 50

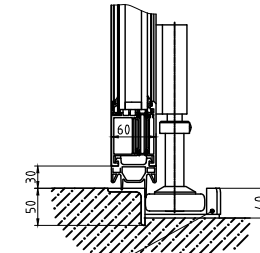
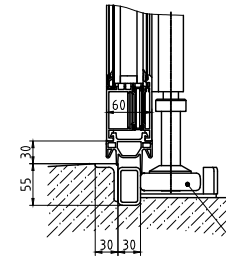

c) Schwelle 20

d) Bodenführung

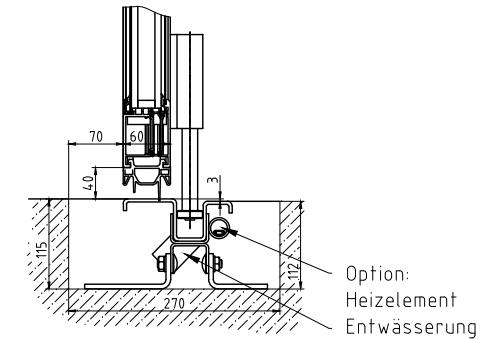
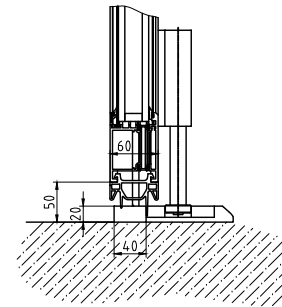

Horizontalschnitt (M1:50)

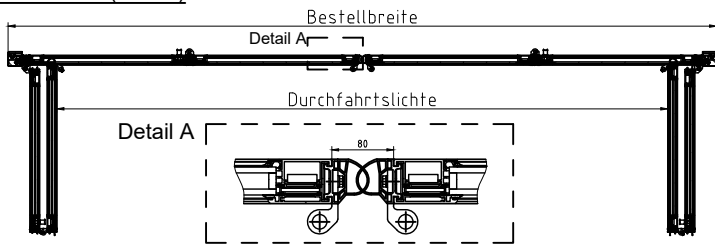

Montagesituationen (M1:10)

a) Vor bzw. hinter der Leibung VL/HL

b) In der Leibung IL

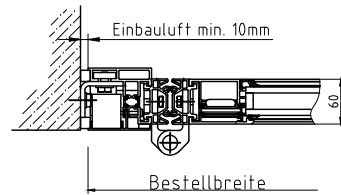
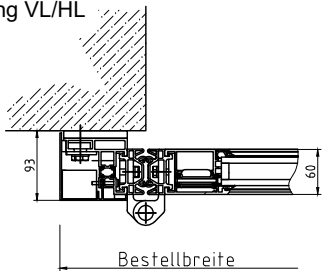

Architektenblatt
AL603F EEF