

Skillair® 100 IN-SERIES REGULATOR

TECHNICAL DATA	
Threaded inlet port	G 1/4"
Threaded user port	G 1/8"
Setting range	0-2 - 0-4 - 0-8 - 0-12
Max. input pressure	1.5 MPa - 15 bar - 217 psi
Flow rate at 6.3 bar (0.63 MPa-91 psi)	500 NI/min
ΔP 0.5 bar (0.05 MPa - 7 psi)	18 scfm
Flow rate at 6.3 bar (0.63 MPa-91 psi)	950 NI/min
ΔP 1 bar (0.1 MPa - 14 psi)	34 scfm
Fluid	Filtered, lubricated or unlubricated compressed air. Lubrication, if used, must be continuous.
Max temperature	°C 50
at 1 MPa; 10 bar; 145 psi	°F 122
Weight	Kg 0.4
Wall fixing screws	M4x50
Mounting	In any position
Pressure gauge port	G 1/8"
Notes on use	The regulator pressure must always be set upwards. For increased sensitivity, use a pressure regulator with a rated pressure as close as possible to the required value.

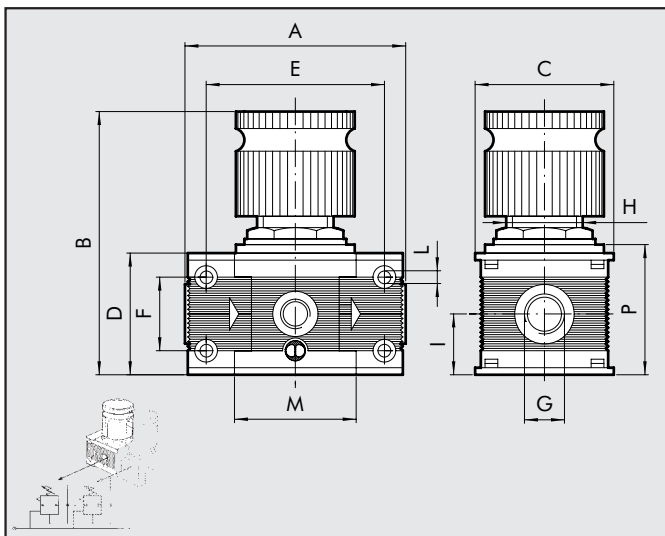

DIMENSIONS



	REG 100	REG 100
Threaded port	G 1/4"	G 3/8"
A		78
B		98
C		50
D		43
E		63
F		26
G	G 1/4"	G 3/8"
H		30x1.5
I		21.5
L		M4 hole
M		43
P		46

ORDERING CODES

Cod.	Descrizione
100 IN-SERIES REGULATOR	
3202101A	100 IN-SERIES REG. 0-2 WITHOUT TERMINALS
3202102A	100 IN-SERIES REG. 0-4 WITHOUT TERMINALS
3202103A	100 IN-SERIES REG. 0-8 WITHOUT TERMINALS
3202104A	100 IN-SERIES REG. 0-12 WITHOUT TERMINALS
3202101	100 IN-SERIES REG. 1/4 0-2
3202102	100 IN-SERIES REG. 1/4 0-4
3202103	100 IN-SERIES REG. 1/4 0-8
3202104	100 IN-SERIES REG. 1/4 0-12
3302101	100 IN-SERIES REG. 3/8 0-2
3302102	100 IN-SERIES REG. 3/8 0-4
3302103	100 IN-SERIES REG. 3/8 0-8
3302104	100 IN-SERIES REG. 3/8 0-12

Several of these Skillair® regulators can be mounted in series, all fed by the same pressure. They can give different set pressures, each independent of the previous regulator. Operating compressed air can be taken from the pressure gauge ports (G 1/8").

