

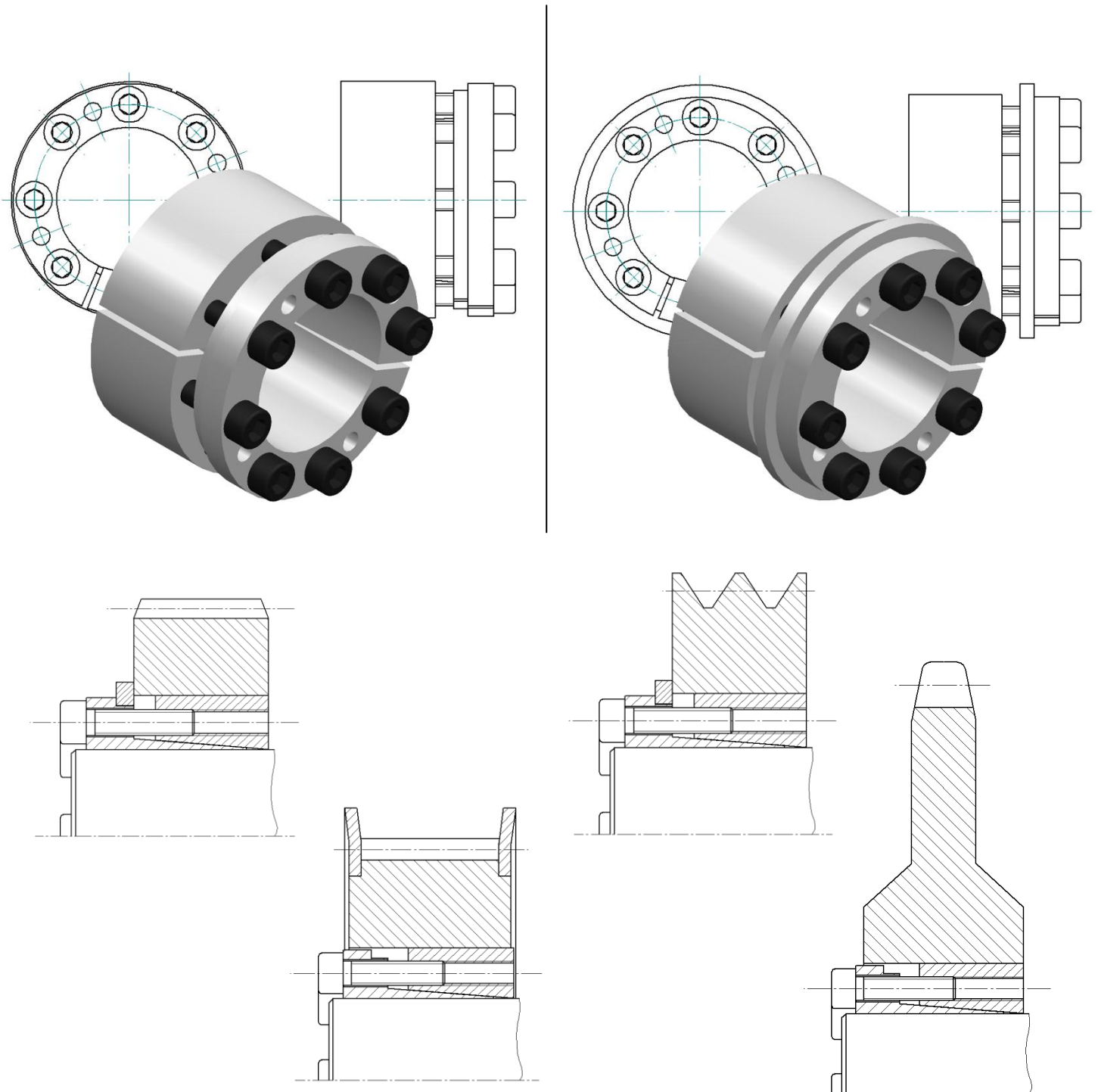

## Clamping Set KBS 70 / KBS 71



**KBS 70 / KBS 71 Clamping Set** is a frictionally engaged detachable shaft-hub connection for cylindrical shafts and bores without keyway.



## Features

- delivered in mounted condition
- self-centering
- concentricity **0,02 – 0,04 mm**

## **Tolerances, Surfaces**

- a good turning process is sufficient: **Rz ≤ 16 µm**
- maximum tolerance: **d = h8/H8 – shaft/hub**

## Components of clamping set

### KBS 70

### KBS 71

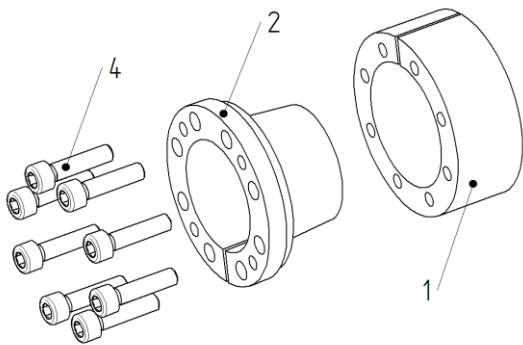

Image 2) KBS 70

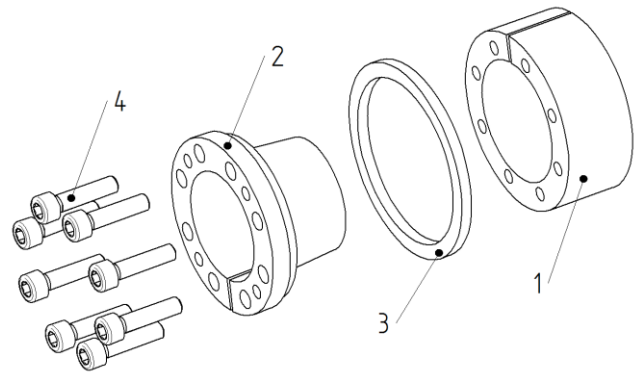

Image 3) KBS 71

Component	Quantity	Description
1	1	outer ring (slotted)
2	1	inner ring (slotted)
3	1	axial ring
4	see catalogue	socket head screw DIN EN ISO 4762



### **Information!**

Contaminated or used clamping elements have to be detached and cleaned prior to installation. Then apply a thin layer of low viscosity oil (e.g. Ballistol all-purpose oil or Klüber Quietsch-Ex).

### Assembly of the clamping set

- Check shaft- and hub-position regarding the stipulated tolerance (h8/H8).
- Clean contact surfaces of clamping set as well as contact surfaces of shift and hub (see image 3). Then apply a thin layer of low viscosity oil (e.g. Ballistol oil or Klüber Quietsch-Ex)

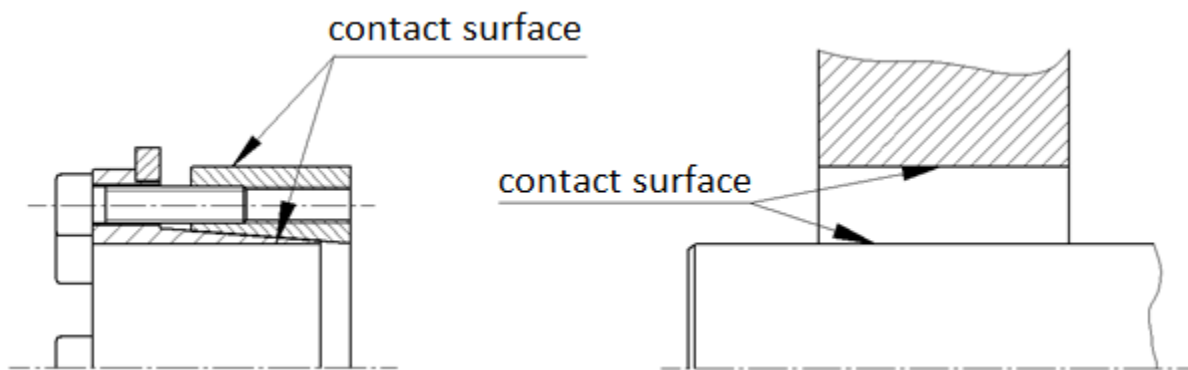

Image 4) Cleaning the contact surfaces



**ATTENTION!**

Do not use any oil, grease or sliding-grease paste reducing the coefficient of friction significantly. Oil-free assembly of the clamping set cones may result in different values shown in the table and the values calculated.

- Slightly loosen the clamping screws. Insert clamping set KBS 70 / KBS 71 between shaft and hub.
- Slightly tighten the clamping screws manually and align the clamping set with the hub.
- Tighten clamping screws crosswise and evenly in several turns with the tightening torque specified in table 1. Repeat this procedure until a  $\frac{1}{4}$ -turn is no longer possible. Then tighten the clamping screws in sequence according to the specified tightening torque.

**Table 1:**

Clamping Set	KBS 70 / KBS 71				
Thread Size M	M6	M8	M10	M12	M14
Tightening Torque $T_A$ [Nm]	17	41	83	145	230



**Information!**

Assembly of the KBS 70 may result in an axial displacement between hub and shaft.



## Disassembly of the clamping set



**DANGER!**

Loosened or falling drive components may result in personal injuries or damage to machines. Please secure all drive components prior to disassembly.

- Loosen all clamping screws evenly in sequence and unscrew them.
- Screw the clamping screws into the draw-off thread of the outer ring (component 1) (see image 5)
- Tighten clamping screws crosswise and evenly with a  $\frac{1}{4}$ -turn. Increase loosening torque gradually until the outer ring (component 1) and the inner ring (component 2) are separated.
- Remove the loosened clamping set between shaft and hub.

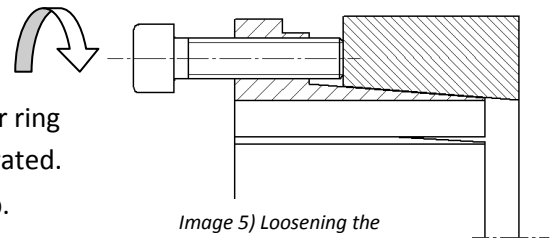

Image 5) Loosening the clamping set



**ATTENTION!**

Non-observance of these instructions or non-consideration of operating conditions selecting the clamping set may impair the function.

**Disposal:** Defective clamping sets must be cleaned and scrapped.