



# igubal® KBRM und KBLM | Gelenkkopf | mm

KBRM/KBLM

mm

igubal®-Gelenkköpfe

Telefon (0 22 03) 96 49-145  
Telefax (0 22 03) 96 49-334

igus® GmbH  
51147 Köln

Internet: [www.igus.de](http://www.igus.de)  
E-Mail: [info@igus.de](mailto:info@igus.de)

51.6



Standardausführung



Ausführung mit Metallhülse (MH)

Angaben in mm

Aufbau der Bestellnr.:

K B ... M-02



## igubal®-Gelenkköpfe mit Rechts- und Linksgewinde

- wartungsfreier Trockenlauf
- hohe Steifigkeit
- sehr hohe Dauerfestigkeit bei wechselnden Belastungen
- Ausgleich von Fluchtungsfehlern
- Ausgleich von Kantenbelastungen
- unempfindlich gegen Schmutz, Staub und Flusen
- korrosions- und chemikalienbeständig
- hohes Dämpfungsvermögen
- geeignet für rotierende, oszillierende und lineare Bewegungen
- sehr geringes Gewicht
- Maßreihe K nach DIN ISO 12240
- Ausführung mit Metallhülse in der Kalotte für erhöhtes Anzugdrehmoment



### Material

Gehäuse: igumid G  
 ▶ Seite 70.6  
 Kalotte: iglidur® W300  
 ▶ Kap. 5

## Belastungsdaten

igubal®-Gelenkköpfe KBRM/KBLM

Bestellnummer		maximale stat. Zugbelast.		maximale Querbelastr.		minimale	max. Anzieh-	max. Anzieh-	
Rechtsgewinde	Linksgewinde	kurzz.	langz.	kurzz.	langz.	Einschraubtiefe	Drehmoment	Moment durch Kalotte	Moment durch Kalotte
		[N]	[N]	[N]	[N]	Gewinde	Innengewinde	o. Metallhülse	m. Metallhülse
		[N]	[N]	[N]	[N]	[mm]	[Nm]	[Nm]	[Nm]
KBRM-02	KBLM-02	200	100	50	25	4	0,3	1	-
KBRM-03	KBLM-03	800	400	100	50	5	0,5	2	4
KBRM-05 M4	KBLM-05 M4	1000	500	250	125	7	0,75	5	12
KBRM-05	KBLM-05	1000	500	250	125	7	1,0	5	12
KBRM-06	KBLM-06	1400	700	400	200	8	1,5	10	15
KBRM-08	KBLM-08	2100	1050	700	350	11	5,0	12	40
KBRM-10	KBLM-10	3100	1550	800	400	13	15,0	20	50
KBRM-10 F	KBLM-10 F	3100	1550	800	400	13	6,0	20	50
KBRM-12	KBLM-12	3600	1800	900	450	15	20,0	30	70
KBRM-12 F	KBLM-12 F	3600	1800	900	450	15	15,0	30	70
KBRM-14	KBLM-14	4000	2000	1000	500	17	25,0	35	75
KBRM-16	KBLM-16	4200	2100	1300	650	19	30,0	40	110
KBRM-16 F	KBLM-16 F	4200	2100	1300	650	19	27,5	40	110
KBRM-18	KBLM-18	4600	2300	1600	800	21	45,0	45	150
KBRM-20	KBLM-20	5400	2700	2100	1050	22	60,0	55	200
KBRM-20 M20	KBLM-20 M20	5400	2700	2100	1050	22	60,0	55	200
KBRM-22	KBLM-22	7000	3500	2200	1100	25	75,0	60	-
KBRM-25	KBLM-25	8500	4250	2300	1150	28	120,0	60	-
KBRM-30	KBLM-30	10500	5250	2500	1250	34	135,0	60	-
KBRM-30 M27x2	KBLM-30 M27x2	10500	5250	2500	1250	34	135,0	60	-

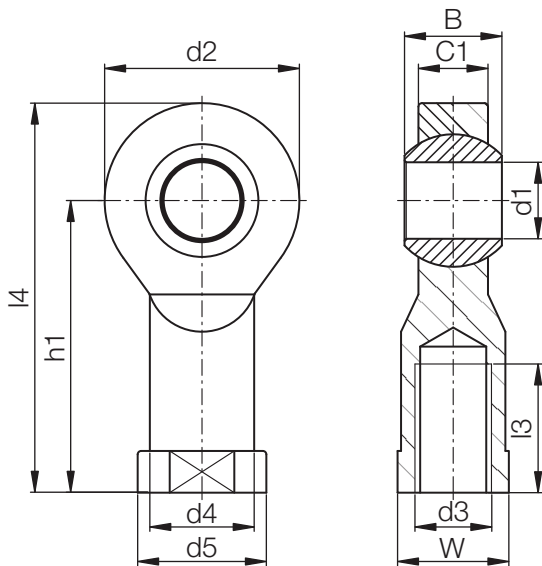

igubal®-Gelenkköpfe  
mm KBRM/KBLM

Telefon (0 22 03) 96 49-145  
Telefax (0 22 03) 96 49-334

### Abmessungen [mm]

igubal®-Gelenkköpfe KBRM/KBLM

Bestellnummer	d1	d2	d3	d4	d5	C1	B	h1	l3	l4	W	max. Kippwinkel
	E10											
Rechtsgewinde	Linksgewinde											
KBRM-02	KBLM-02	2	9	M02	4,0	4,6	3,0	4	12,5	6	17	SW04 30°
KBRM-03	KBLM-03	3	13	M03	6,5	8,0	4,5	6	18,5	8	25	SW06 30°
KBRM-05 M4	KBLM-05 M4	5	18	M04	9,0	12,0	6,0	8	27	10	36	SW09 30°
KBRM-05	KBLM-05	5	18	M05	9,0	12,0	6,0	8	27	10	36	SW09 30°
KBRM-06	KBLM-06	6	20	M06	10,0	13,0	7,0	9	30	12	40	SW11 29°
KBRM-08	KBLM-08	8	24	M08	13,0	16,0	9,0	12	36	16	48	SW14 25°
KBRM-10	KBLM-10	10	30	M10	15,0	19,0	10,5	14	43	20	58	SW17 25°
KBRM-10 F	KBLM-10 F	10	30	M10x1,25	15,0	19,0	10,5	14	43	20	58	SW17 25°
KBRM-12	KBLM-12	12	34	M12	18,0	22,0	12,0	16	50	22	67	SW19 25°
KBRM-12 F	KBLM-12 F	12	34	M12x1,25	18,0	22,0	12,0	16	50	22	67	SW19 25°
KBRM-14	KBLM-14	14	38	M14	20,0	25,0	13,5	19	57	25	76	SW22 25°
KBRM-16	KBLM-16	16	42	M16	22,0	27,0	15,0	21	64	28	85	SW22 23°
KBRM-16 F	KBLM-16 F	16	42	M16x1,5	22,0	27,0	15,0	21	64	28	85	SW22 23°
KBRM-18	KBLM-18	18	46	M18x1,5	25,0	31,0	16,5	23	71	32	94	SW27 23°
KBRM-20	KBLM-20	20	50	M20x1,5	28,0	34,0	18,0	25	77	33	102	SW30 23°
KBRM-20 M20	KBLM-20 M20	20	50	M20x2,5	28,0	34,0	18,0	25	77	33	102	SW30 23°
KBRM-22	KBLM-22	22	56	M22x1,5	30,0	37,0	20,0	28	84	37	112	SW32 22°
KBRM-25	KBLM-25	25	60	M24x2,0	32,0	41,0	22,0	31	94	42	124	SW36 22°
KBRM-30	KBLM-30	30	70	M30x2,0	37,0	50,0	25,0	37	110	51	145	SW41 22°
KBRM-30 M27x2	KBLM-30 M27x2	30	70	M27x2,0	37,0	50,0	25,0	37	110	51	145	SW41 22°

Gelenkköpfe in metrischen Abmessungen mit Metallhülse können bestellt werden mit dem Zusatz **MH** hinter den hier aufgelisteten Bestellnummern, zum Beispiel KBRM-10 **MH** (Innen-Ø: +0,15 mm).

Lieferzeit: ab Lager

Lebensdauerberechnung, 3-D-CAD-Daten und weitere Informationen ► [www.igus.de/de/kbrm](http://www.igus.de/de/kbrm)