

# HALFEN HZA-PS CAST-IN CHANNELS

## TECHNICAL PRODUCT INFORMATION

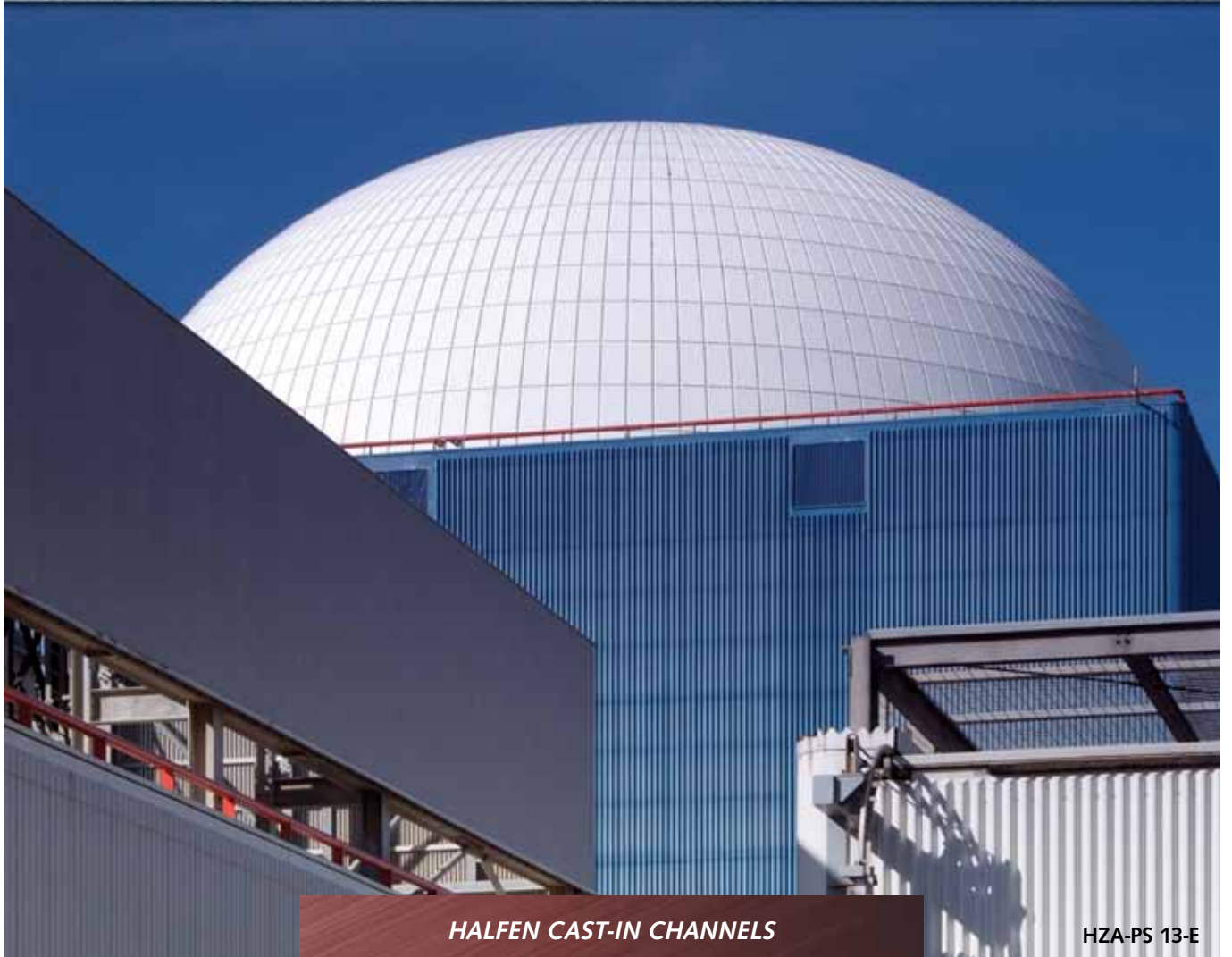

*HALFEN CAST-IN CHANNELS*

HZA-PS 13-E

CONCRETE



**HALFEN**  
YOUR BEST CONNECTIONS

# HALFEN Cast-in channels

## The Benefits at a glance

**O**ffering easy reliable and excellent adjustment, HALFEN Cast-in channels save considerable installation time for connections to concrete. The result: Faster completion of the construction project and reduced costs.

### Safe and reliable

- No damage to supporting reinforcement
- Approved for fire-resistant structural elements
- Can be installed in concrete pressure and tensile-stress zones
- Suitable for dynamic loading
- Building authority approval
- Easy checking
- Minimizes the opportunity for installation errors
- Safer for installers, without the health hazards caused by vibrating powertools, noise, dust, sparks, or fumes

### Quick and economical

- Adjustable component anchoring
- No welding or drilling
- Extremely economical
- Installation with simple tools, saves money
- Pre-engineered to reduce construction time
- Large selection for the most varied requirements

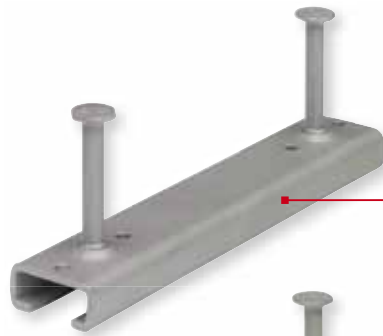

HALFEN HTA-CE Cast-in channels  
**cold-formed**

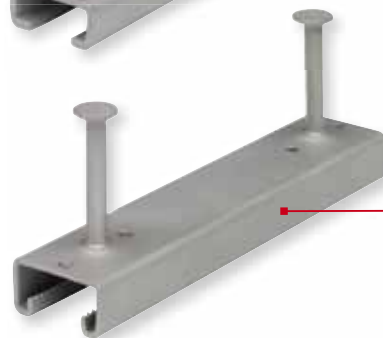

HALFEN HZA Cast-in channels  
**cold-formed, toothed**



toothed

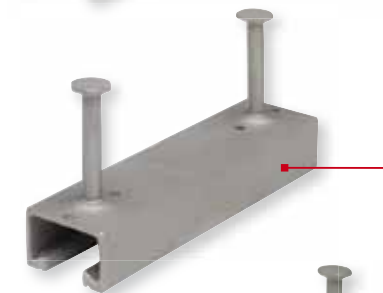

HALFEN HTA-CE Cast-in channels  
**hot-rolled**



suitable for dynamic loading



HALFEN HZA Cast-in channels  
**DYNAGRIP  
hot-rolled, toothed**



toothed



3D - loading



suitable for dynamic loading

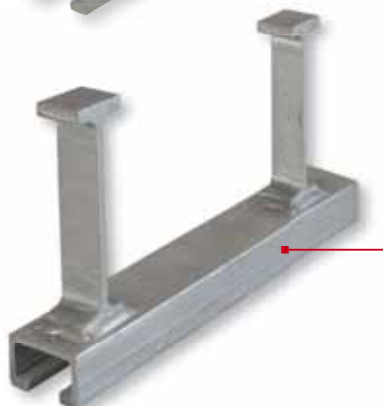

HALFEN HZA-PS Cast-in channels  
**hot-rolled, toothed**



toothed



3D - loading



suitable for dynamic loading



suitable for seismic loading



suitable for safety relevant areas

# HALFEN HZA-PS CAST-IN CHANNELS

## General

### Approvals

HALFEN Cast-in channels, available hot-dip galvanized or made from stainless steel, have received building authority approvals by the German Construction Materials Supervisory Board (DIBt).

Cast-in channels are set flush to the concrete surface. The channels use T-bolts or toothed bolts with associated nuts and washers, to reliably secure structural elements.

**HTA:** App. No. Z-21.4-34  
**HTA-CE:** App. No. ETA-09/0339  
**HZA 41/22:** App. No. Z-21.4-145  
**HZA Dynagrip:** App. No. Z-21.4-1691



### Evaluation Report

HALFEN HZA-PS Cast-in channels are suitable for applications in safety relevant areas of nuclear power plants and other nuclear facilities.

They fulfill the higher requirements for taking extraordinary impact loads from outside (EVA) and inside (EVI) e.g. earthquake, plane crash or explosions.

**HZA-PS:**  
Evaluation Report  
Technical University of Dortmund  
09.05.18-E

proved by:



Fakultät Architektur und Bauingenieurwesen  
Betonbau – Befestigungstechnik



### Approvals on the internet

The approvals can be found at [www.halfen.de/service/brochures](http://www.halfen.de/service/brochures), or simply scan the code, select the required document and click to download as a PDF file.

### Fire Protection

HALFEN Cast-in channels HTA and HZA, in combination with HALFEN Bolts, have been certified for use in fire-exposed structural elements.

The anchoring channels installed according to the above mentioned approvals section 3.2.7 and the respective appendices maintain the fire rating of 60 or 90 minute respectively for concrete structures.



### Quality

Quality is the outstanding feature of our products. HALFEN materials and products are subjected to most stringent quality control procedures. A quality inspection by the **German Lloyd Certification GmbH** has verified that our quality management system meets the requirements of the DIN EN ISO 9001:2008 standard. The **RAL quality mark** is a guarantee for coherence with the products' technical characteristics and the product

service including specification, quality-management, logistics, professional technical consultation, high-quality technical documentation and software. Furthermore fulfilment of guaranteed services and impartial tender processing is ensured.

Additional to the general high quality standard HZA-PS Channels are delivered in principle with a 3.1. certification according to DIN EN 10204.



Cert.-No. QS-281 HH





# HALFEN HZA-PS CAST-IN CHANNELS

## Application Examples



Nuclear power plant, operator Vattenfall AB

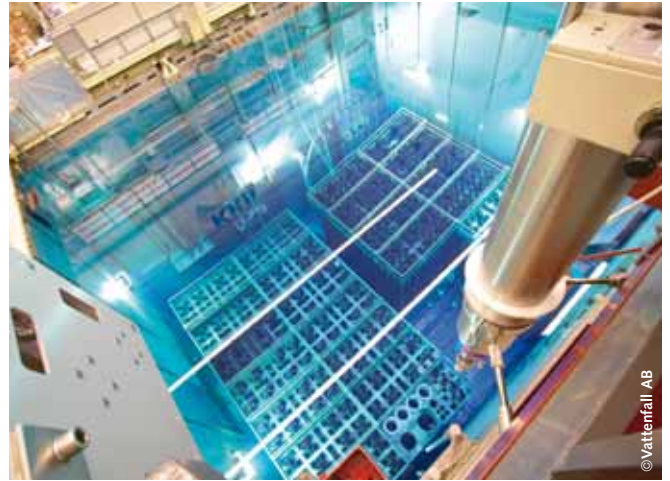

Fuel element cooling pond



Cable trays accurately levelled by bolting to vertical toothed channels



Pipe support bolted to ceiling



Nuclear power plant under construction



# HALFEN HZA-PS CAST-IN CHANNELS

## Application Examples



Turbine in nuclear power plant



Turbine hall in nuclear power plant



Cantilever for support of pipes mounted to vertical toothed channel



Pipe support using vertical channel



Adjustable pipe support using a cantilever with vertical toothed channel

# HALFEN HZA-PS CAST-IN CHANNELS

## Application Examples

**Application example 1**

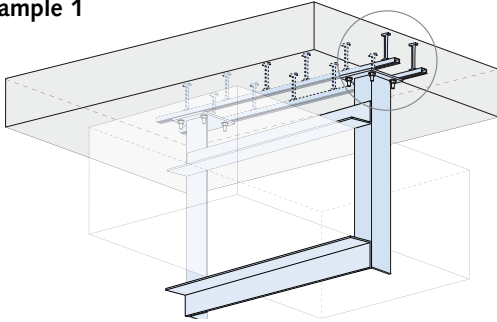

**Air ventilation duct** supported by welded steel frame anchored to concrete floor slab by a toothed channel pair

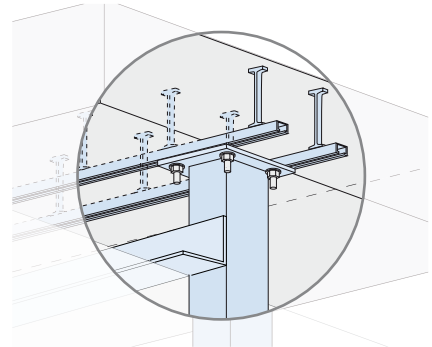

**Application example 2**

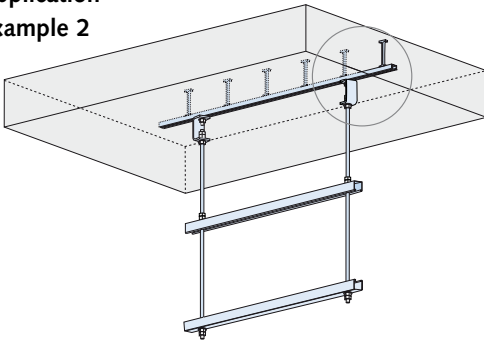

**Air ventilation duct** supported by a light weight construction bolted to floor slab using a toothed channel

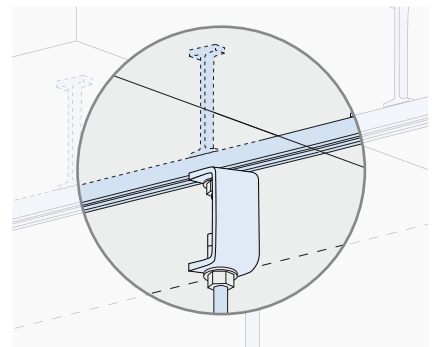

**Application example 3**

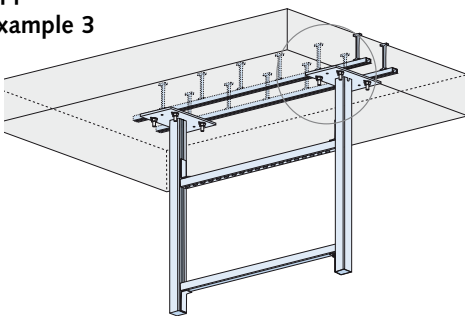

**Air ventilation duct** supported by a HALFEN Framing system attached to concrete slab by a toothed channel pair

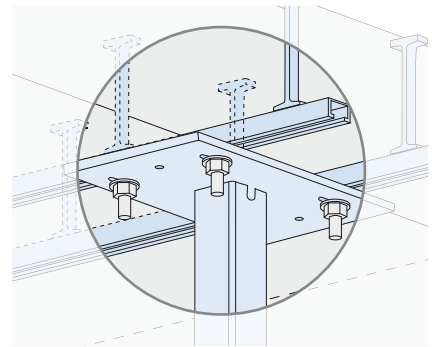

**Application example 4**

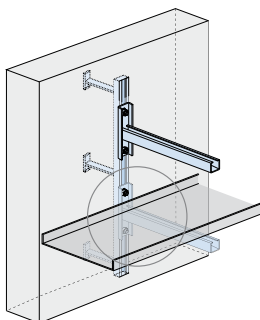

**Cable tray** supported by cantilever brackets mounted to a vertical toothed channel

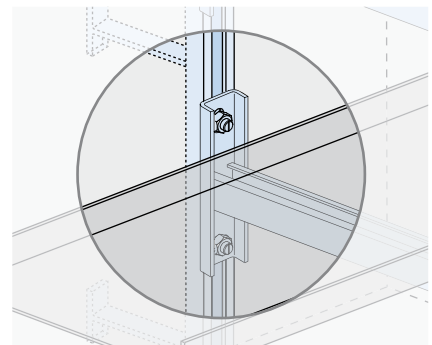

# HALFEN HZA-PS CAST-IN CHANNELS

## Safety Relevant Aspects

### Standard application

For applications in normal concrete constructions such as office buildings, schools, industrial buildings or in non-safety relevant areas of nuclear power plants HALFEN HTA-CE & HZA Channels are officially approved, and recommended. In such cases the typical maximum crack width within the concrete structure is up to 0.3 mm.

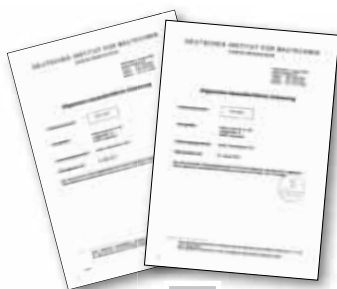
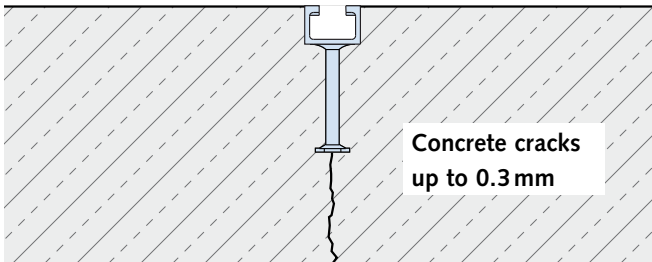
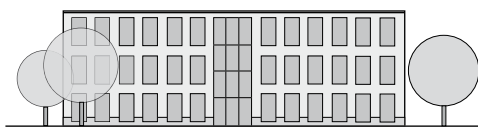

Approvals

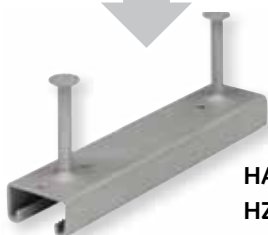

HALFEN HTA-CE and HZA Cast-in channels

### Safety relevant applications

However for safety relevant areas in nuclear power plants or other nuclear facilities higher safety requirements for taking impact loads from outside (EVA) or inside (EVI) must be considered. The suitability of the HZA-PS Channels for such extra-ordinary impact loads has been verified by simulated application tests. All the tests were carried out in concrete with opening and closing cracks varying from 1.0mm up to 1.5 mm. The results are summarized in the evaluation report 09.05.18-E (→ see also pages 8+9).

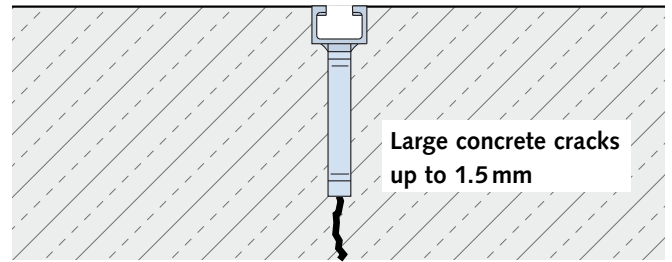
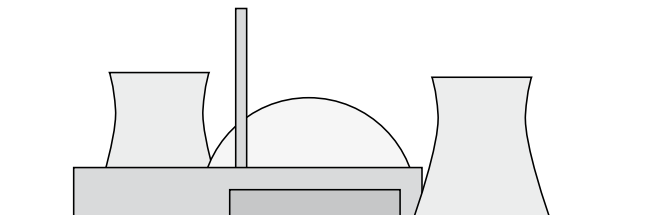

Expert Report

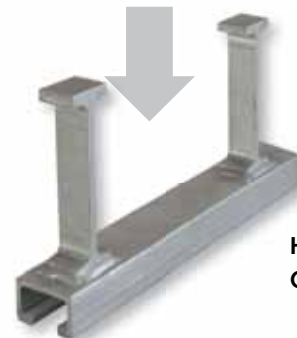

HALFEN HZA-PS Cast-in channel



## HALFEN HZA-PS CAST-IN CHANNELS

### Tests

In nuclear power plants and nuclear facilities different requirement categories must be considered (see DIN 25449):

**Category A3:** Loading cases which occur only one time during the lifetime of the facility:

- earthquake
- plane crash
- exterior explosion
- interior explosion
- differential pressure
- supporting forces etc.

**Category A2:** Loading cases which occur less than ten times during the lifetime of the facility.

**Category A1:** Loading cases which occur more than ten times during the lifetime of the facility.

As a result of the higher demands of category 3 and 2 you have to consider wider concrete cracks. Therefore the behaviour of the anchoring systems is examined in additional suitability tests with crack widths more than 0.4 mm. The existing guideline from the German institute for Building Technology (DIBt) for the use of post installed anchors in nuclear power plants was the basis for the determination of the additional tests.

Examples of the tests conducted include the following:

1. Pull out test where the anchor was placed in a 1.0mm wide concrete crack

2. Pull out test where the anchor was placed in a 1.5mm wide concrete crack

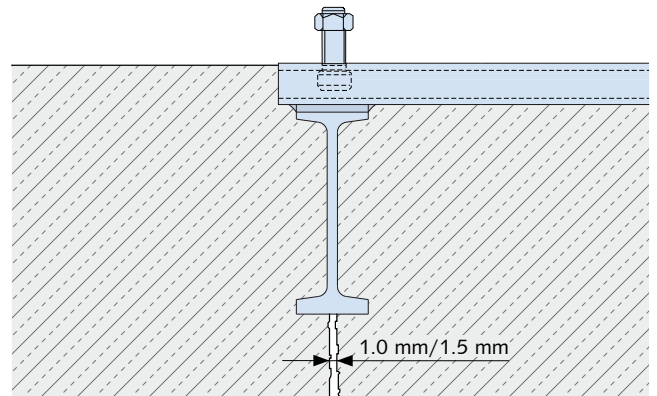

Anchor placement straight in the 1.0 and 1.5 mm concrete crack.

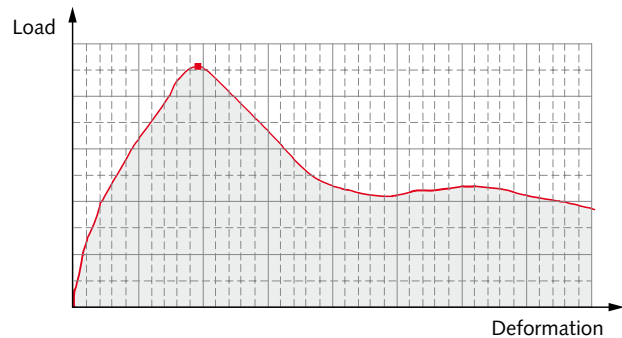

Load-deformation diagram of a pull out test showing the steady load increases with a low deformation until maximum load is achieved.



Test setup pull out tests



# HALFEN HZA-PS CAST-IN CHANNELS

## Tests

### 3. Performance test in an opening and closing concrete crack

For this purpose 10 alterations of the concrete crack width between 1.0 and 1.5 mm were performed in a frequency of 0.2 Hz while the anchor channel was loaded with a constant tension load. Afterwards a pull out test in the widest concrete crack 1.5 mm was carried out.

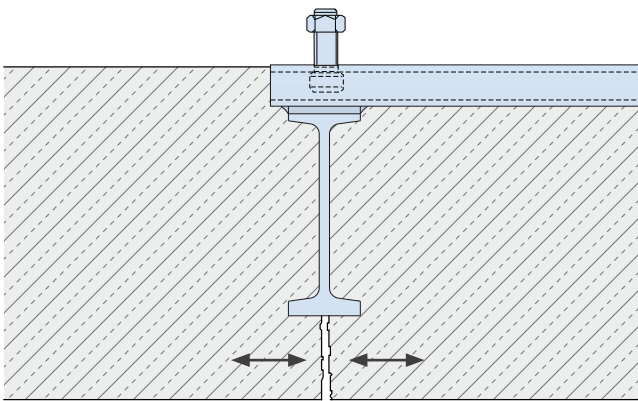

Anchor placement straight in the opening and closing concrete crack.

### 4. Cyclic load change in a wide concrete crack

In this test the concrete crack is opened up to 1.5 mm and then a tension load is applied to the cast-in channel. Then the cast-in channel is completely unloaded. In this way 15 load cycles with a frequency  $F < 1$  Hz follow. Finally a pull-out test in the open crack of 1.5 mm is conducted.

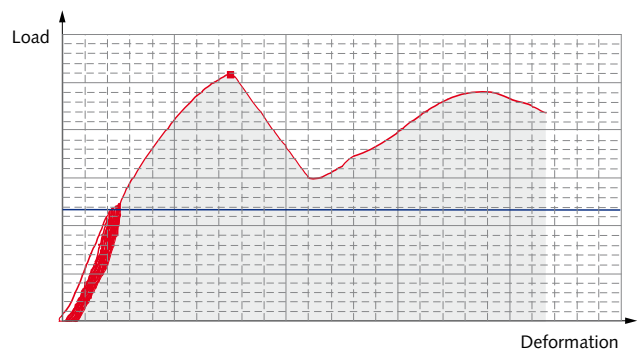

Load-deformation diagram - even after the cyclic load test the final pull out test shows a steady rise with only low deformation.

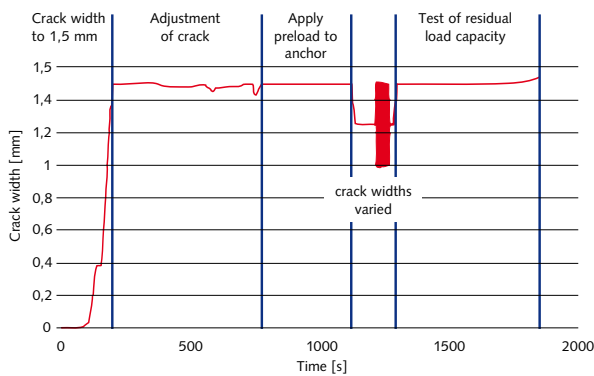

Chronological test procedure

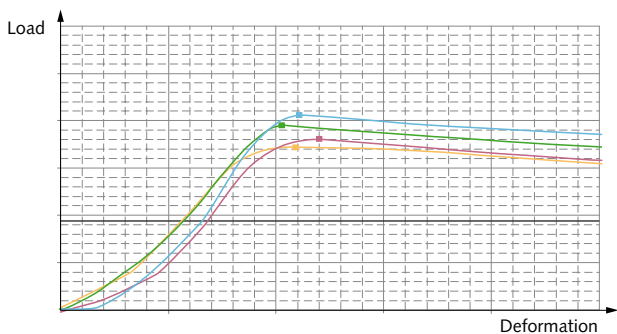

Load-deformation diagram: shows ductile behaviour during the final pull out test.



Test setup for cyclic load test

# HALFEN HZA-PS CAST-IN CHANNELS

## Product Overview

### HZA-PS Cast-in channels

#### HZA-PS 29/20

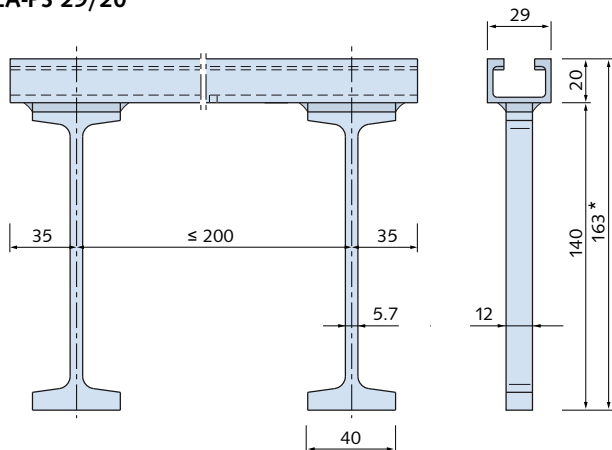

#### HZA-PS 38/23

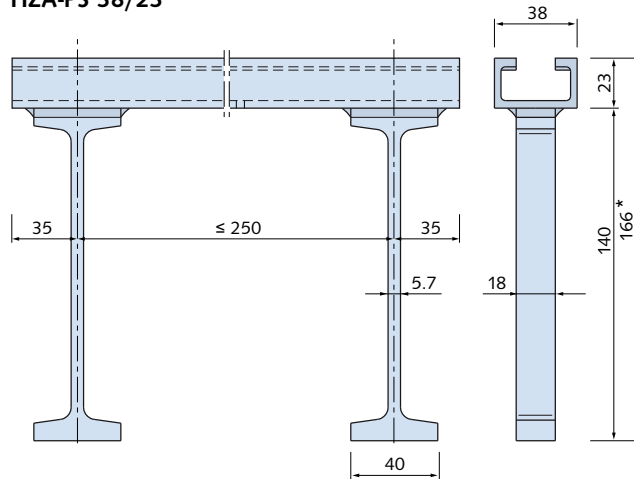

#### HZA-PS 53/34

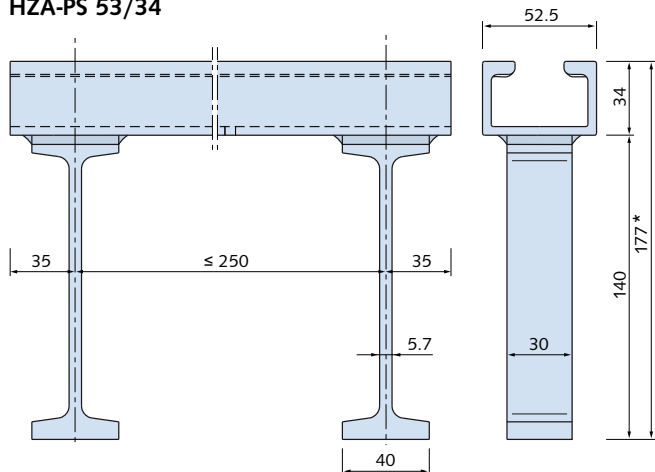

#### Product identification

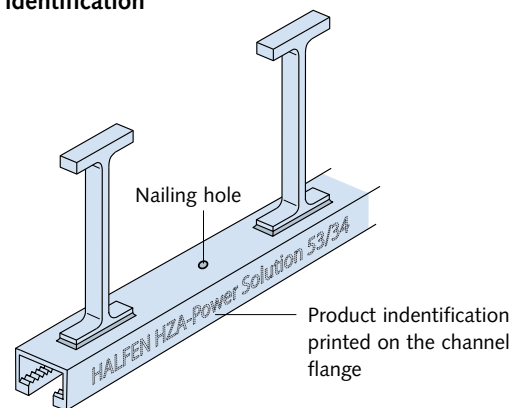

\*including a tolerance of  $\leq 3$  mm

### Available lengths and anchor placement (produced to order)

HZA-PS 38/23, 53/34 - Standard lengths			
Length [mm] / Number of anchors			
200 / 2	350 / 3	550 / 3	800 / 4
1050 / 5	3030 / 13	6070 / 25	

HZA-PS 29/20 - Standard lengths			
Length [mm] / Number of anchors			
200 / 2	350 / 3	550 / 4	800 / 5
1050 / 6	3030 / 16	6070 / 31	

HZA-PS 38/23, 53/34 - Fixed standard lengths			
Length [mm] / Number of anchors			
-	1300 / 6	1550 / 7	1800 / 8
2050 / 9	2300 / 10	2550 / 11	2800 / 12
-	3300 / 14	3550 / 15	3800 / 16
4050 / 17	4300 / 18	4550 / 19	4800 / 20
5050 / 21	5300 / 22	5550 / 23	5800 / 24

HZA-PS 29/20 - Fixed standard lengths			
Length [mm] / Number of anchors			
1250 / 7	1450 / 8	1650 / 9	1850 / 10
2050 / 11	2250 / 12	2450 / 13	2650 / 14
2850 / 15	-	3250 / 17	3450 / 18
3650 / 19	3850 / 20	4050 / 21	4250 / 22
4450 / 23	4650 / 24	4850 / 25	5050 / 26
5250 / 27	5450 / 28	5650 / 29	5850 / 30

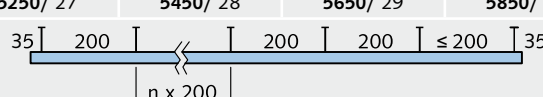
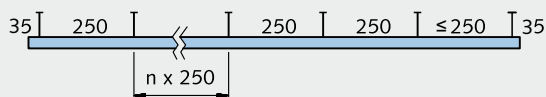

# HALFEN HZA-PS CAST-IN CHANNELS

## Product Overview

### HZS bolts - available lengths

**HZS 29/20**  
M12

**HZS 38/23**  
M16

**HZS 53/34**  
M20

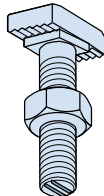
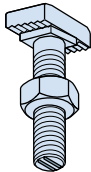
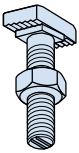

HZS T-Bolt lengths		
Bolt type/ channel profile	Bolt diameter (mm)	Grade 8.8 Bolt length (mm)
HZS 53/34	M20	65, 100
HZS 38/23	M16	40, 60, 80
HZS 29/20	M12	60, 80

For bolts in other lengths and diameter please contact HALFEN (→ see page 19).

### Product identification

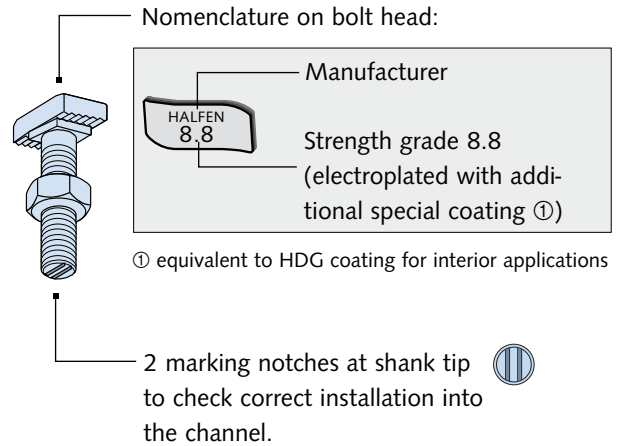

### Example order code for bolts:

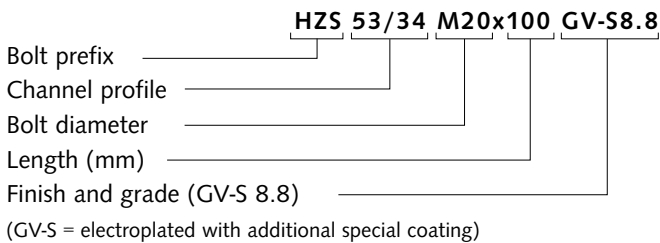

### Example order code for channels:

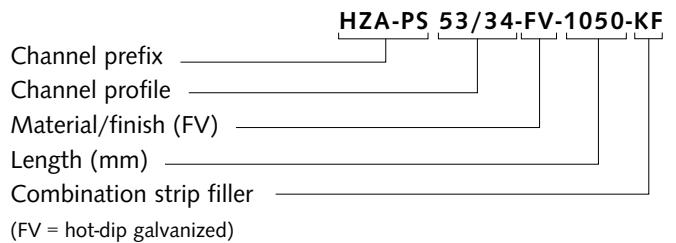

### Tender specifications

#### 1. HALFEN Cast-in channels

##### 1.1 HALFEN Channel type HZA-PS – Power Solution

HALFEN Cast-in channel HZA-PS \_\_\_\_\_, hot dip galvanized (FV) with Combination Strip Filler (KF), suitable for adjustable connections to concrete in safety relevant areas of nuclear plants or other nuclear installations, channel length \_\_\_\_\_ mm, design resistance  $F_{Rd} =$  \_\_\_\_\_ kN in all directions, up to \_\_\_\_\_ kN dynamic loading, deliver and install according to the HALFEN assembly instruction.

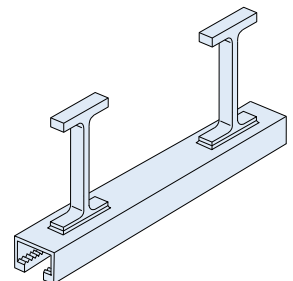

#### 2. HALFEN Bolts

##### 2.1 HALFEN Bolts type HZS

HALFEN toothed bolt HZS \_\_\_\_\_ belonging to correspondent HALFEN Cast-in channel HZA-PS, electroplated with special coating, including nut, deliver and install according to the HALFEN assembly instruction.

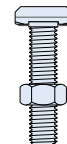



# HALFEN HZA-PS CAST-IN CHANNELS

## Technical Data

### Load capacities

#### Loads

All the values shown are design resistance capacities and should therefore be compared against fully factored loads (ULS)

e.g.  $F_{Ed} = \gamma_G G_k + \gamma_Q Q_k$

where

- $\gamma_G$  = partial factor for permanent loads
- $g_k$  = characteristic value of permanent loads (dead load)
- $\gamma_Q$  = partial factor for variable loads
- $q_k$  = characteristic value of variable loads (imposed or live load)

Design resistance $F_{Rd}$ ; valid for h.d.g material		s = anchor spacing see page 10						
$F_{Rd}$ with simultaneous loading in <u>all</u> directions		Single loads		Load pairs				
Concrete $\geq C20/25$								
To check: ① (A) $F_{Ed} = \sqrt{N_{Ed}^2 + V_{xEd}^2 + V_{yEd}^2} \leq F_{Rd}$ (B) $V_{x,Ed} \leq 0.8 \times F_{Rd}$ (single load)		$F_{Rd}$ [kN]		$F_{Rd}$ [kN] ②				
		$b_1 \geq 250$		$p_i = 50$	$p_i = 100$	$p_i = 150$	$p_i = 200$	$p_i = 250$
HZA-PS profile ①	53/34	30.8			19.25	22.0	25.7	30.8
	38/23	16.8	9.4	10.5	12.0	14.0	16.8	
	29/20	11.2	6.3	7.5	9.0	11.2	11.2	

① Check B is only necessary, if there is an arrangement of 2 or more bolts connecting **one** component.

② Intermediate values may be linearly interpolated.

Minimum edge distances and spacings							
	$a_r$	$a_a$	$a_e$	$a_f$	$a_{r1}$	$a_{a1}$	d
HZA-PS 53/34	200	400	175	350	200	400	180 + c
HZA-PS 38/23	150	300	130	250	225	150	170 + c
HZA-PS 29/20	100	200	80	200	140	125	160 + c

c = min concrete cover (specified by others)

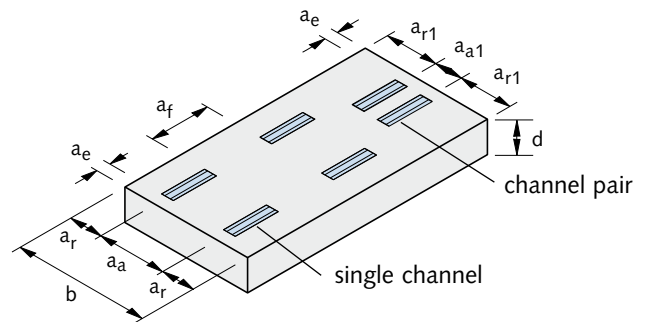

HZA T-Bolt capacities					
Bolt diameter (mm)	Grade 8.8			Moment capacity $M_{Rd}$ (Nm)	Tensile capacity $F_{Rd}$ (kN)
	Tightening torque (Nm)				
	HZA 29/20	HZA 38/23	HZA 53/34		
M20	-	-	350	303.0	79.0
M16	-	120	-	155.4	50.5
M12	80	-	-	61.2	27.2

Load amplitude for load cycles of $N = 2 \times 10^6$		
	Design load amplitude $\Delta F$ in tension S275	Permissible bolts
HZA-PS 53/34	12.0	M20
HZA-PS 38/23	3.0	M16
HZA-PS 29/20	2.0	M12

## HALFEN HZA-PS CAST-IN CHANNELS

### Product Advantages

#### The anchor head

The wide, almost parallel anchor head is a positively interlock connection and causes a very effective load transmission due to the low bearing pressure below the head. Furthermore there is an additional enormous advantage in

concrete designed for wide cracks. Due to the low motion of the anchorage system during the opening and closing cracks, a safe fastening with low deformation, can be guaranteed.

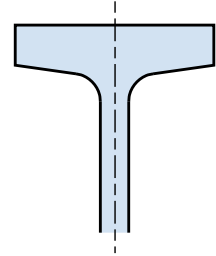

#### The anchoring depth

Deep anchoring guarantees a high loading capacity and compensates for the concrete attenuation due to wide cracks. Concrete elements in security relevant areas are frequently heavily reinforced. The enhanced anchoring depth

guarantees an ideal load impact regarding the reinforcement layers. At the same time, the channel body (maximum height 34 mm) can be implemented easily in common concrete covers of approx. 35–60 mm.

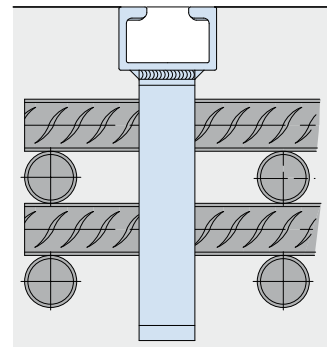

#### The channel profile

The manufacturing process of the hot rolled channels enables efficient design of the channel cross section. This means that the channel lips are thicker and stronger than the flanges or channel backs. This feature avoids lip deformation while enabling safe and efficient transfer of impact loads through the channel profile for

dispersal into the concrete structure. The hot rolling process also prevents manufacturing distortion over the channel length and provides good bearing for attached components. Dynamic loads can also be safely transmitted because the hot rolled material has low internal stresses.

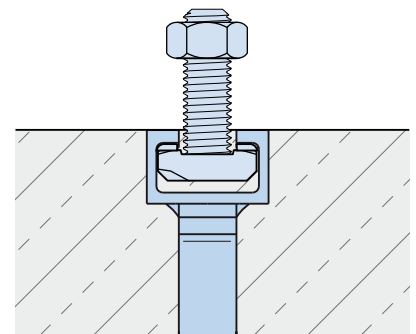

#### The toothed channel lips

During the rolling process robust internal teeth are formed from the material of the channel lips. With a pitch of only 3.0 mm the channel teeth positively interlock with toothed HALFEN Bolts and thus provide a safe load capacity in the longitudinal direction of the channel.

Due to this toothed channels are very useful for application in seismic areas or in special load cases such as explosion or collision loads. For activating load capacities in the longitudinal direction of the channels only a defined torque has to be considered (see page 12).

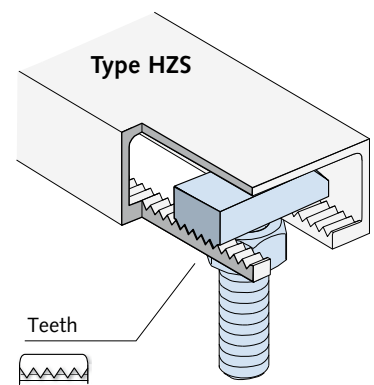

## HALFEN HZA-PS CAST-IN CHANNELS

### Product Advantages

#### The anchor foot

All four sides of the anchor foot are solidly welded to the back of the channel.

This allows an efficient and balanced transmission of static and above all dynamic loads from the channel into the anchor.

The considerable over-design of the weld's length gives an additional safety feature. This is enhanced by regular selective ultimate load checks of welded anchors as part of our quality assurance programme.



#### T- bolts

All HZS Bolts for the HZA-PS Systems are exclusively available in high strength class 8.8. This guarantees that the bolt, even if there is an additional moment acting on the bolt, can transmit forces safely into the channels. The tightening torque guarantees a positive

interlocking between the bolt and the channel toothing. This is important for the loading capacity in the longitudinal direction of the channels. Thus the given tightening torques have to be maintained.



#### Quality

Our production plant in Langenfeld/ Germany is certified according to DIN EN ISO 9001. This means a permanent controlling and maintenance of all machines and processes at the factory. All controls are according to the HALFEN quality system QS-based on DIN EN ISO 9001. The HALFEN production plant is certified for welding processes according to international standard DIN EN ISO 3834-2 and according to German DIN 18800-7. To ensure the quality of all incoming materials HALFEN has installed incoming inspections:

Certificates according to EN 10204 for delivered material are sent by suppliers for each delivery. They are checked by QM-department before goods are placed into stock. Additionally there is a check of chemical and mechanical properties and geometric measurement.

During the production process all products are subject to a random quality testing including ultimate tensile test. In addition, the thickness of the zinc layers are checked regularly in order to guarantee the corrosion resistance.

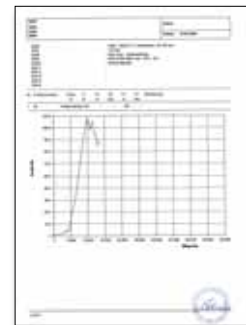

#### Certification

Under DIN EN 10204 the following documents can be issued: Acceptance certificates based on non specific test (production certificate 2.1 and production certificate 2.2 [a more detailed description]) and acceptance certificates based on specific test on the delivered product (inspection certificate 3.1).

Customer request for an acceptance certificate 3.1 have to be made at order placement. The certificate 3.1 issued by the manufacturer confirms, that the delivered products fulfill the requirements, indicating the test results.





## HALFEN HZA-PS CAST-IN CHANNELS

### Summary

Over its 80 years history HALFEN has become the world leader in providing adjustable anchoring systems.

Cold-rolled HALFEN Channels fulfill all basic requirements of an adjustable, user-friendly and safe anchoring systems. The product family is enhanced by hot-rolled channels that offer further advantages such as the safe support of dynamic loads.

More sophisticated HALFEN Channels are the toothed hot-rolled range, which are able to assume loads in longitudinal direction.

The new HZA-PS product range is the logical enhancement of the toothed hot rolled channel allowing its use in security relevant areas of nuclear power stations and nuclear facilities.

The special testing programme made at the Technical University of Dortmund/Germany confirms that the HALFEN Channels HZA-PS 53/34, HZA-PS 38/23 and HZA-PS 29/20 are all suitable for the special loading conditions required for safe use in the above mentioned areas.

Those additional investigations and tests consider extreme interior and exterior loading effects like earthquake, explosion load as well as plane impact loads.

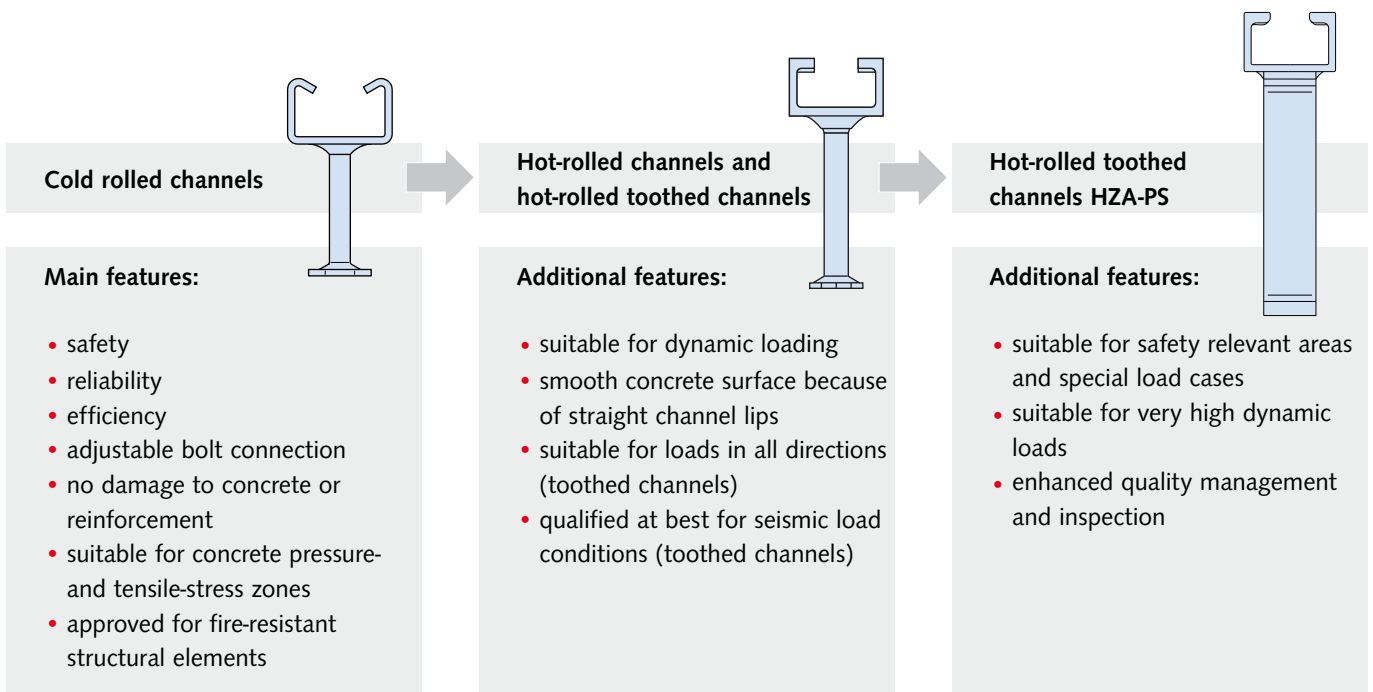

For specific details please contact:  
**HALFEN Engineering Support**  
 Phone: +49 (0) 2173 - 970 9020  
 E-Mail: es.ans@halfen.com

For more information on HALFEN HTA-CE and HZA Cast-in channels please refer to our **Technical Product Information "HALFEN Cast-in channels"**.



# HALFEN HZA-PS CAST-IN CHANNELS

## Product Overview HALFEN HTA-CE/HZA Cast-in Channels

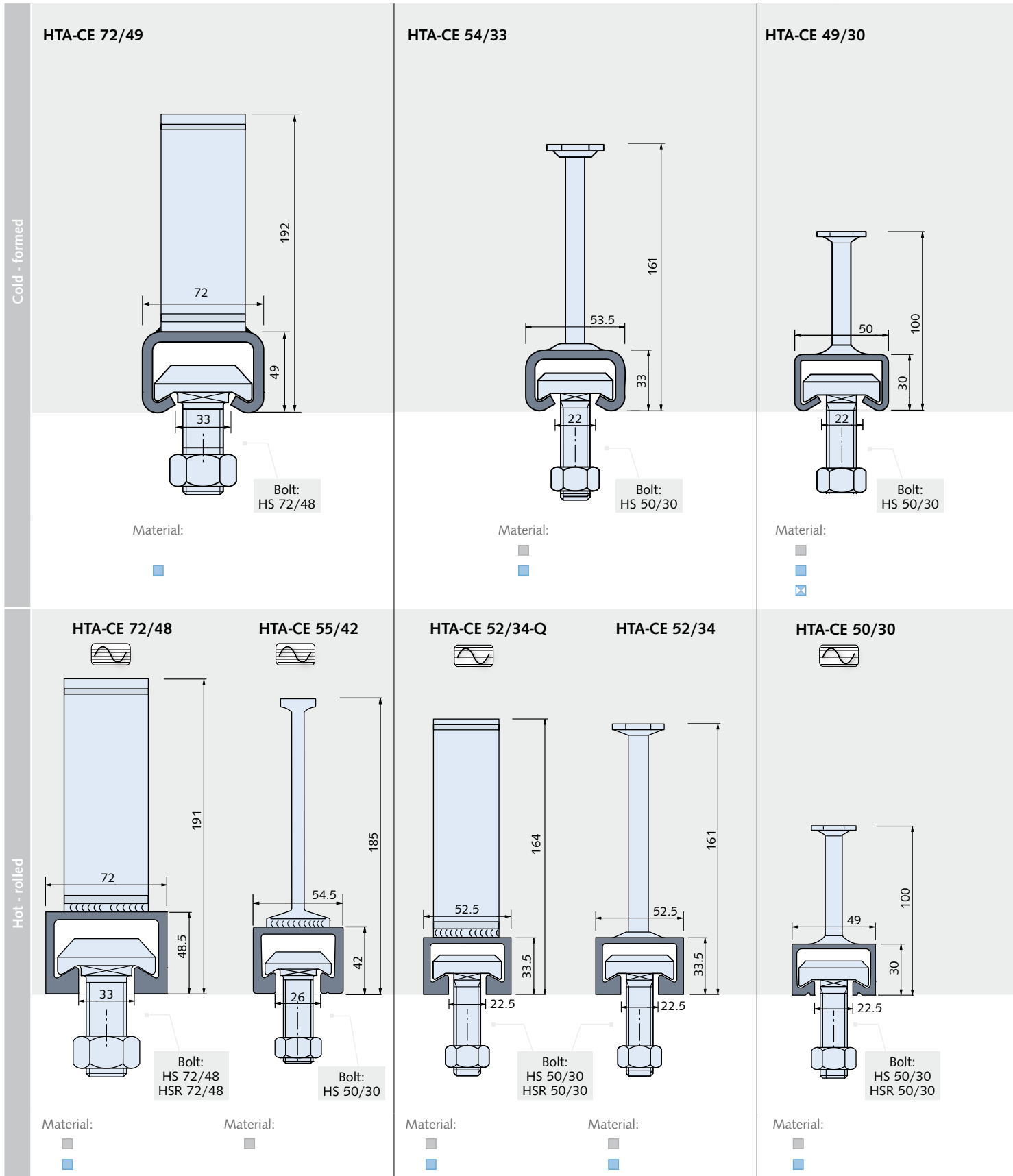

# HALFEN HZA-PS CAST-IN CHANNELS

## Product Overview HALFEN HTA-CE/HZA Cast-in Channels

- **FV** = steel S235JR, hot-dip galvanized
- **A4** = stainless steel 1.4571/1.4404/1.4401
- **HCR** = stainless steel 1.4547/1.4529

**HTA-CE 40/25**

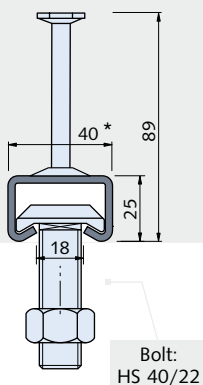

Bolt: HS 40/22

Material:

- \* 40
- \* 39.5

**HZA 41/22**

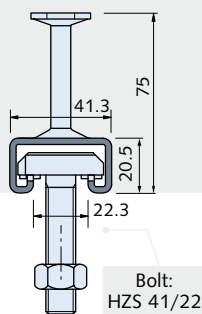

Bolt: HZS 41/22

Material:

- 
- 

**HTA-CE 38/17**

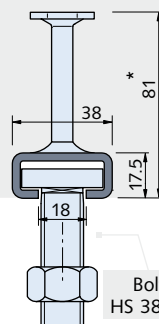

Bolt: HS 38/17

Material:

- \* 68.5
- \* 68.5
- \* 77.9

**HTA-CE 28/15**

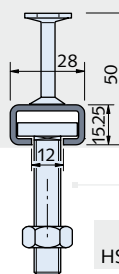

Bolt: HS 28/15

Material:

- 
- 
- 

**HZA 38/23**

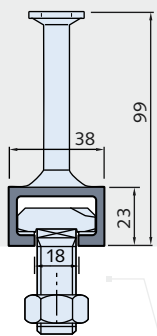

Bolt: HZS 38/23

Material:

- 
- 

**HTA-CE 40/22**

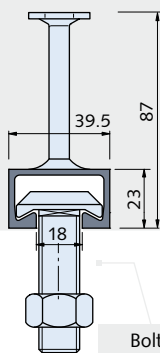

Bolt: HS 40/22  
HSR 40/22

Material:

- 
- 

**HZA 29/20**

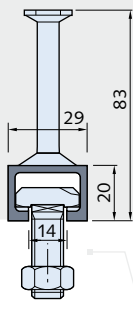

Bolt: HZS 29/20

Material:

- 

**HZA 53/34**

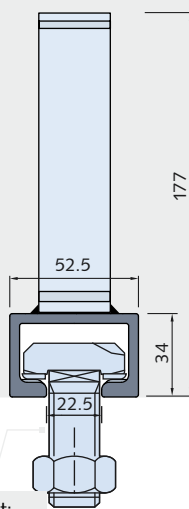
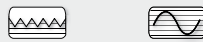

Bolt: HZS 53/34

Material:

- 
- 

**HZA 64/44**

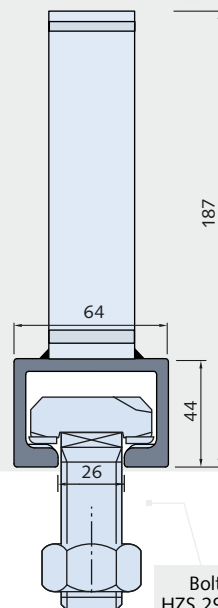
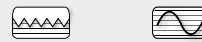

Bolt: HZS 29/20



# Connection Solutions.

## The HALFEN Product range.

Footbridge Simone de Beauvoir, Paris

### FIXING SYSTEMS, FRAMING SYSTEMS AND ACCESSORIES

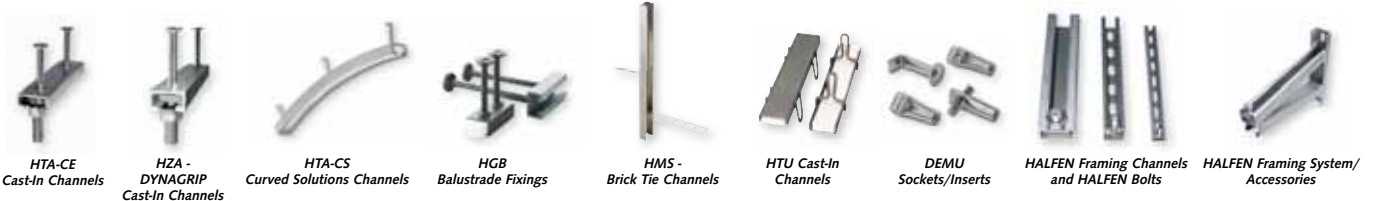

### REINFORCEMENT SYSTEMS

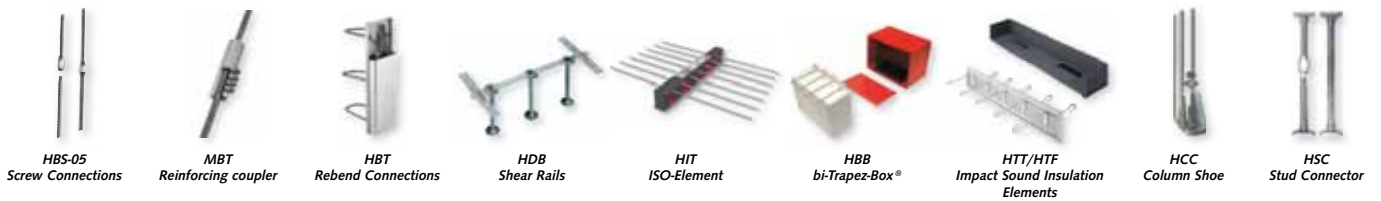

### LIFTING SYSTEMS, CONCRETE PRE-CAST SYSTEMS, NATURAL STONE SYSTEMS, BRICKWORK SUPPORT SYSTEMS, ROD SYSTEMS



## CONTACT HALFEN WORLDWIDE

HALFEN is represented by subsidiaries in the following 14 countries, please contact us:

Austria	HALFEN Gesellschaft m.b.H. Leonard-Bernstein-Str. 10 1220 Wien	Phone: +43-1-259 6770 E-Mail: office@halfen.at Internet: www.halfen.at	Fax: +43-1-259-6770 99
Belgium / Luxembourg	HALFEN N.V. Borkelstraat 131 2900 Schoten	Phone: +32-3-658 07 20 E-Mail: info@halfen.be Internet: www.halfen.be	Fax: +32-3-658 15 33
China	HALFEN Construction Accessories Distribution Co.Ltd. Room 601 Tower D, Vantone Centre No. A6 Chao Yang Men Wai Street Chaoyang District Beijing · P.R. China 100020	Phone: +86-10 5907 3200 E-Mail: info@halfen.cn Internet: www.halfen.cn	Fax: +86-10 5907 3218
Czech Republic	HALFEN-DEHA s.r.o. Business Center Šafránkova Šafránkova 1238/1 155 00 Praha 5	Phone: +420-311-690 060 E-Mail: info@halfen-deha.cz Internet: www.halfen-deha.cz	Fax: +420-235-314 308
France	HALFEN S.A.S. 18, rue Goubet 75019 Paris	Phone: +33-1- 445231 00 E-Mail: halfen@halfen.fr Internet: www.halfen.fr	Fax: +33-1-445231 52
Germany	HALFEN Vertriebsgesellschaft mbH Katzbergstrasse 3 40764 Langenfeld	Phone: +49-2173-970-0 E-Mail: info@halfen.de Internet: www.halfen.de	Fax: +49-2173-970 225
Italy	HALFEN S.r.l. Soc. Unipersonale Via F.lli Bronzetti N° 28 24124 Bergamo	Phone: +39-035-0760711 E-Mail: info@halfen.it Internet: www.halfen.it	Fax: +39-035-0760799
Netherlands	HALFEN b.v. Oostermaat 3 7623 CS Borne	Phone: +31-742-6714 49 E-Mail: info@halfen.nl Internet: www.halfen.nl	Fax: +31-742 6726 59
Norway	HALFEN AS Postboks 2080 4095 Stavanger	Phone: +47-51 82 34 00 E-Mail: post@halfen.no Internet: www.halfen.no	Fax: +47-51 82 34 01
Poland	HALFEN Sp. z o.o. Ul. Obornicka 287 60-691 Poznan	Phone: +48-61-622 14 14 E-Mail: info@halfen.pl Internet: www.halfen.pl	Fax: +48-61-622 14 15
Sweden	Halfen AB Box 150 435 23 Mölnlycke	Phone: +46-31-98 58 00 E-Mail: info@halfen.se Internet: www.halfen.se	Fax: +46-31-98 58 01
Switzerland	HALFEN Swiss AG Hertistrasse 25 8304 Wallisellen	Phone: +41-44-849 78 78 E-Mail: mail@halfen.ch Internet: www.halfen.ch	Fax: +41-44-849 78 79
United Kingdom / Ireland	HALFEN Ltd. Humphrys Road · Woodside Estate Dunstable LU5 4TP	Phone: +44-1582-47 03 00 E-Mail: info@halfen.co.uk Internet: www.halfen.co.uk	Fax: +44-1582-47 03 04
United States of America	HALFEN USA Inc. 8521 FM 1976 P.O. Box 547 Converse, TX 78109	Phone: +1 800.423.91 40 E-Mail: info@halfenusa.com Internet: www.halfenusa.com	Fax: +1 877.683.4910
<b>For countries not listed</b> HALFEN International	HALFEN International GmbH Liebigstr. 14 40764 Langenfeld / Germany	Phone: +49-2173-970-0 E-Mail: info@halfen.com Internet: www.halfen.com	Fax: +49-2173-970-849

Furthermore HALFEN is represented with sales offices and distributors worldwide. Please contact us: [www.halfen.com](http://www.halfen.com)

### NOTES REGARDING THIS CATALOGUE

**Technical and design changes reserved.** The information in this publication is based on state-of-the-art technology at the time of publication. We reserve the right to make technical and design changes at any time. HALFEN GmbH shall not accept liability for the accuracy of the information in this publication or for any printing errors.

The Quality Management System of Halfen GmbH is certified for the locations in Germany, France, the Netherlands, Austria, Poland, Switzerland and the Czech Republic according to **DIN EN ISO 9001:2008**, Certificate No. QS-281 HH.





For further information please contact: [www.halfen.com](http://www.halfen.com)