

PLAQUE DE FROTTEMENT, ACIER, CNOMO



2962.84.45.



A

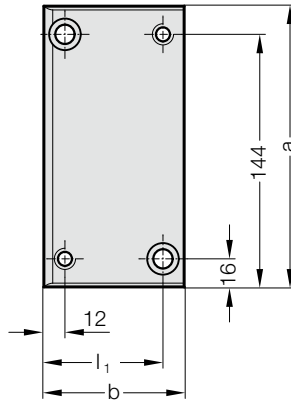

B

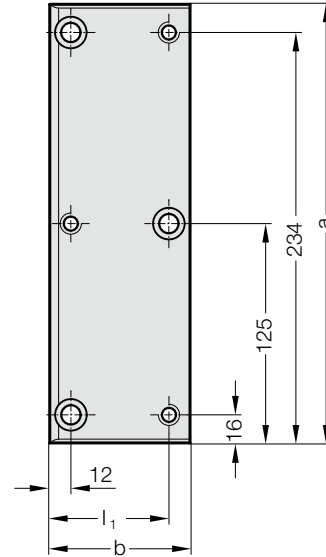

2962.84.45.

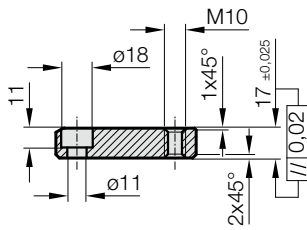

Matière :

Acier, trempé superficiellement

Remarque :

Livraison sans les vis.

Fixation :

Utiliser des vis à tête cylindrique
DIN EN ISO 4762 M10.

2962.84.45. Plaque de frottement, Acier, CNOMO

N° de commande	Forme	b	a	l_1	Nombre de lamages de vis	Nombre de filetage
2962.84.45.050.17.160	A	50	160	38	2	2
2962.84.45.050.17.250	B	50	250	38	3	3
2962.84.45.080.17.160	A	80	160	68	2	2
2962.84.45.080.17.250	B	80	250	68	3	3