

ÜBERLAUFKEIL, BRONZE MIT FESTSCHMIERSTOFF, VDI 3357

2960.92.

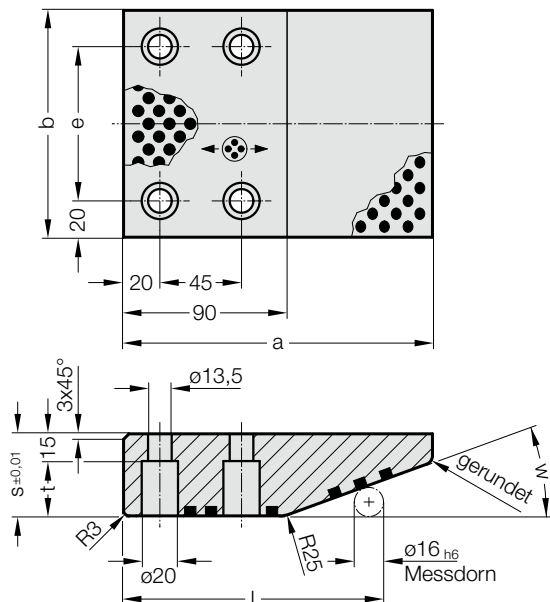

Einbaubeispiel

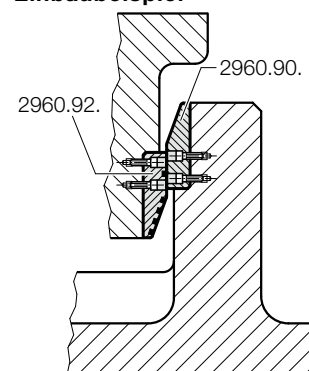

2960.92. Überlaufkeil, Bronze mit Festschmierstoff, VDI 3357

Bestell-Nummer	b	a	s	e	t	w	l
2960.92.100.170.045	100	170	45	60	30	20	143,37
2960.92.125.170.045	125	170	45	85	30	20	143,37
2960.92.150.170.045	150	170	45	110	30	20	143,37
2960.92.200.170.045	200	170	45	160	30	20	143,37
2960.92.100.150.045	100	150	45	60	30	30	127,86
2960.92.100.170.060	100	170	60	60	45	30	127,86
2960.92.125.150.045	125	150	45	85	30	30	127,86
2960.92.125.170.060	125	170	60	85	45	30	127,86
2960.92.150.150.045	150	150	45	110	30	30	127,86
2960.92.150.170.060	150	170	60	110	45	30	127,86
2960.92.200.150.045	200	150	45	160	30	30	127,86
2960.92.200.170.060	200	170	60	160	45	30	127,86

Werkstoff:

Bronze mit Festschmierstoff, wartungsarm

Hinweis:

Lieferung ohne Schrauben.

Befestigung:

Zylinderschrauben
DIN EN ISO 4762
M12 verwenden.