

CONTROLLABLE GAS SPRINGS

HOT FORMING

CONTROL SYSTEM

COMPRESSED AIR MAINTENANCE UNIT

2489.00.48

Compressed air maintenance unit

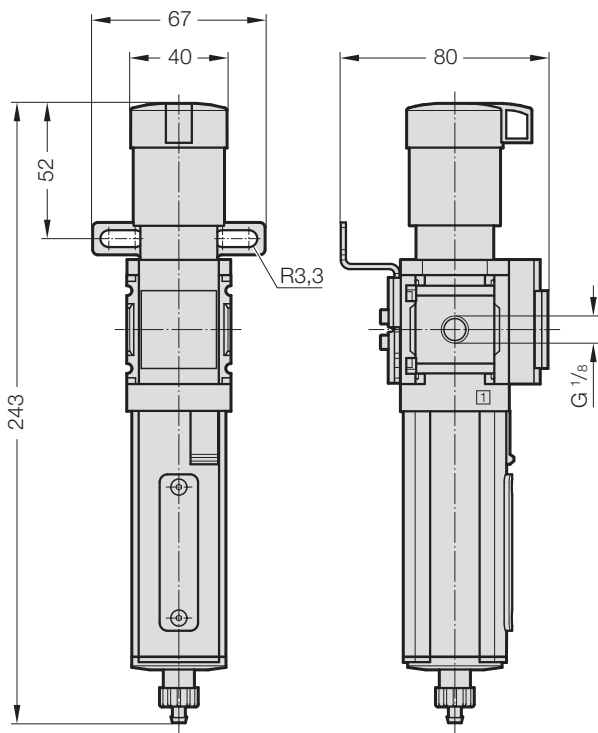

Compressed air maintenance unit for cleaning and regulating the control air of the cartridge valve in the active gas spring.

TECHNICAL DATA:

Filter unit 40 mm

Operating pressure 0,8 bar up to 14 bar

Ambient temperature -10°C up to 60°C

NOTE:

Order number for replacement filter cartridge: 2489.00.48.1

We recommend changing the filter cartridge every 200 operating hours or at least 1x per year.

In case of high water content or high contamination of the conveyed compressed air, the cycle must be adjusted.