

# LIFTER PIN FOR PRESS TOOL STRIPS

244.00.2.

Mounting example

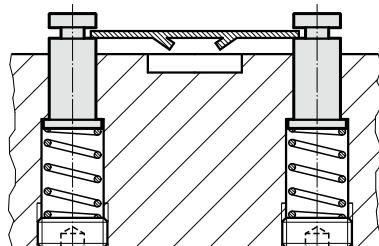
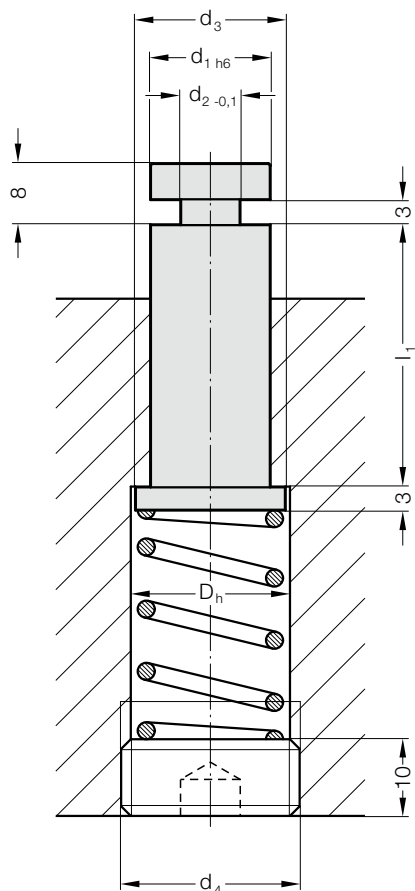

**Description:**

Combination progression dies with certain forming stages can be equipped advantageously with springloaded lifter pins. FIBRO Lifter Pins 244.00.2., available in four sizes, can be used to assume the double function of lifting and guiding the strip. The amount of lift is a function of the counterbore-depth.

**Material:**

No 1.7131, case-hardened

**Execution:**

ground

**Note:**

For ordering code of screw plug 241.00.1. and helical spring see spring range on pages chapter F.

**244.00.2. Lifter pin for press tool strips**

d <sub>1</sub>	8	10	13	16
d <sub>2</sub>	5	6	7	8
d <sub>3</sub>	10	12	16	20
D <sub>h</sub>	10.5	12.5	16.5	20.5
d <sub>4</sub>	M12x1.5	M14x1.5	M18x1.5	M22x1.5
l <sub>1</sub>				
20	●			
25	●		●	
32	●	●	●	●
40	●	●	●	●
50		●	●	●

**Ordering Code (example):**

Lifter pin for press tool strips	=	244.00.2.
Diameter of conduit d <sub>1</sub>	13 mm =	13.
Guide length l <sub>1</sub>	25 mm =	025
Order No	=	244.00.2. 13.025