

CENTERING PIN TO MERCEDES-BENZ STANDARD

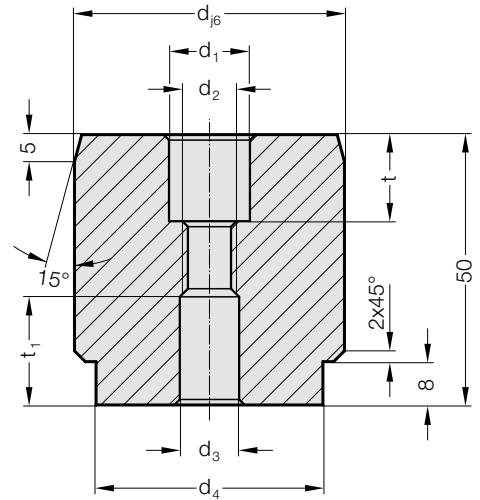

2445.11.



Description:

Using locating holes components, assemblies and tools can be repeatedly centred with high precision on processing machines, measuring equipment and tool components.

Material:

Steel, hardened

Note:

Screws are not included.

Fixing:

Use socket cap screws DIN EN ISO 4762 M6/M8.

2445.11. Centering pin to Mercedes-Benz Standard

Order No	d	d ₁	d ₂	d ₃	d ₄	t	t ₁
2445.11.022	22	11	M8	9	16	13	16
2445.11.025	25	11	M8	9	18	13	16
2445.11.032	32	11	M8	9	25	13	16
2445.11.040	40	15	M10	11	32	16	20
2445.11.050	50	15	M10	11	42	16	20

Mounting example

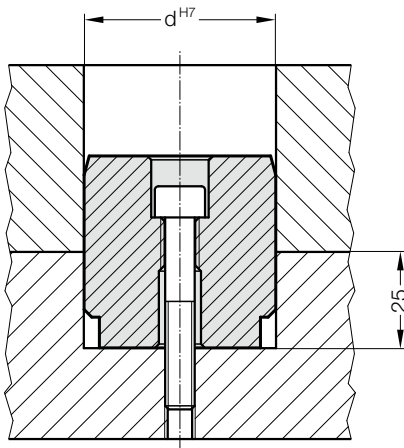

Mounting example

