

# 冲头 DIN 9844 A 型

220.

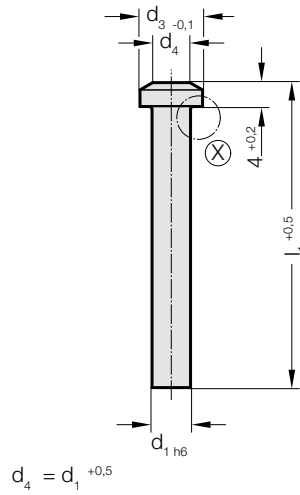
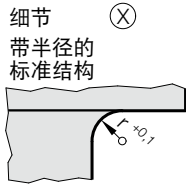

材料:  
HSS  
订购编号 220.3.  
硬度:  
杆部  $64 \pm 2$  HRC  
头部  $52 \pm 3$  HRC

HST  
订购编号 220.4.  
硬度:  
杆部 表面  $\geq 950$  HV 0,3  
头部  $52 \pm 3$  HRC

☞ 材料说明和其他材料见E章开头。

结构:  
凸模头部热墩粗,用切入磨削法精磨支承面和凸模柄部。

支承长度: 71, 90, 112 mm。  
欲订购其它长度和直径时请向我公司咨询!

220. 冲头 DIN 9844 A 型

d <sub>1</sub>	分级			l <sub>1</sub>	71	90	112
	d <sub>1</sub>	d <sub>3</sub>	r				
2	0.1	3.6	0.2		●	●	●
2.3	0.1	4	0.2		●	●	●
2.6	0.1	4.5	0.3		●	●	●
2.9	0.1	5	0.3		●	●	●
3.3	0.1	6	0.3		●	●	●
3.6	0.1	7	0.3		●	●	●
4.1	0.1	8	0.5		●	●	●
4.6	0.1	8.5	0.5		●	●	●
5.1	0.1	9	0.5		●	●	●
5.5	0.1	9.5	0.5		●	●	●
6	0.1	10	0.5		●	●	●
6.5	0.5	10.8	0.7		●	●	●
7.5	0.5	12	0.7		●	●	●
8.5	0.5	13	0.7		●	●	●
9.5	0.5	14.5	0.7		●	●	●
10.5	0.5	16	1		●	●	●
11.5	0.5	18	1		●	●	●
13	0.5	20	1		●	●	●
15	0.5	22	1		●	●	●

订购示例:

冲头 DIN 9844 A 型	=	220.
材料 MAT	HSS	= 3.
切削刃直径 d <sub>1</sub>	5.5 mm	= 0550.
长度 l <sub>1</sub>	71 mm	= 071
订购编号	=	220. 3.0550. 071