

# 带凹槽的导向柱

2022.16.48.

安装示例

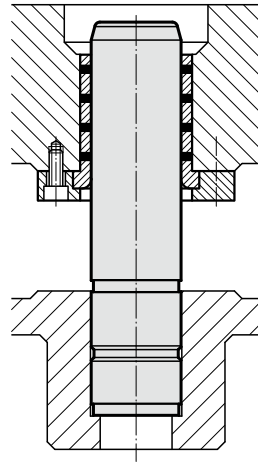
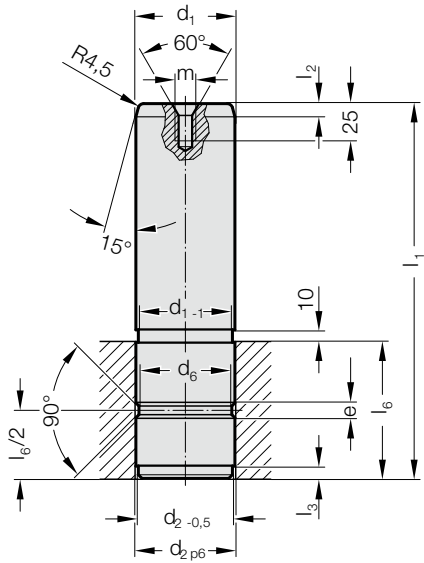

材料:  
 钢, 表层硬化处理  
 表面硬度: 55 + 5 HRC, 淬火深度: 2 + 1,6 mm  
 结构:  
 精密磨削

说明:  
 安装孔 H7。  
 导向柱仅适用于固态润滑剂元件。  
 匹配连接请见D章开始的矩阵表格。

## 2022.16.48. 带凹槽的导向柱

|                | 25            | 30            | 40            | 50            | 60            | 65            | 80            | 100           |
|----------------|---------------|---------------|---------------|---------------|---------------|---------------|---------------|---------------|
| d <sub>1</sub> | 25            | 30            | 40            | 50            | 60            | 65            | 80            | 100           |
| 允许 偏差          | -0,005/-0,015 | -0,005/-0,015 | -0,005/-0,015 | -0,005/-0,015 | -0,01/-0,02   | -0,01/-0,02   | -0,01/-0,025  | -0,01/-0,025  |
| d <sub>2</sub> | 25            | 30            | 40            | 50            | 60            | 65            | 80            | 100           |
| 允许 偏差          | +0,022/+0,035 | +0,022/+0,035 | +0,026/+0,042 | +0,026/+0,042 | +0,032/+0,051 | +0,032/+0,051 | +0,032/+0,051 | +0,037/+0,059 |
| d <sub>6</sub> | 21            | 26            | 36            | 45            | 55            | 60            | 75            | 95            |
| l <sub>2</sub> | 5             | 5             | 5             | 10            | 10            | 10            | 10            | 10            |
| l <sub>3</sub> | 5             | 5             | 5             | 10            | 10            | 10            | 10            | 10            |
| l <sub>6</sub> | 30            | 40            | 50            | 70            | 90            | 100           | 120           | 150           |
| m              | M8            | M8            | M8            | M12           | M12           | M12           | M12           | M12           |
| l <sub>1</sub> |               |               |               |               |               |               |               |               |
| 80             | ●             |               |               |               |               |               |               |               |
| 100            | ●             | ●             |               |               |               |               |               |               |
| 120            | ●             | ●             | ●             |               |               |               |               |               |
| 140            |               | ●             | ●             |               |               |               |               |               |
| 160            |               | ●             | ●             | ●             |               |               |               |               |
| 180            |               | ●             | ●             | ●             | ●             |               |               |               |
| 200            |               |               | ●             | ●             | ●             | ●             |               |               |
| 220            |               |               |               |               | ●             | ●             |               |               |
| 250            |               |               |               | ●             | ●             | ●             | ●             |               |
| 300            |               |               |               | ●             | ●             | ●             | ●             | ●             |
| 350            |               |               |               |               | ●             | ●             | ●             | ●             |
| 400            |               |               |               |               |               |               | ●             | ●             |

### 订购示例:

带凹槽的导向柱 = 2022.16.48.  
 导向装置直径 d<sub>1</sub> 60 mm = 060.  
 长度 l<sub>1</sub> 200 mm = 200  
 订购编号 = 2022.16.48. 060. 200