

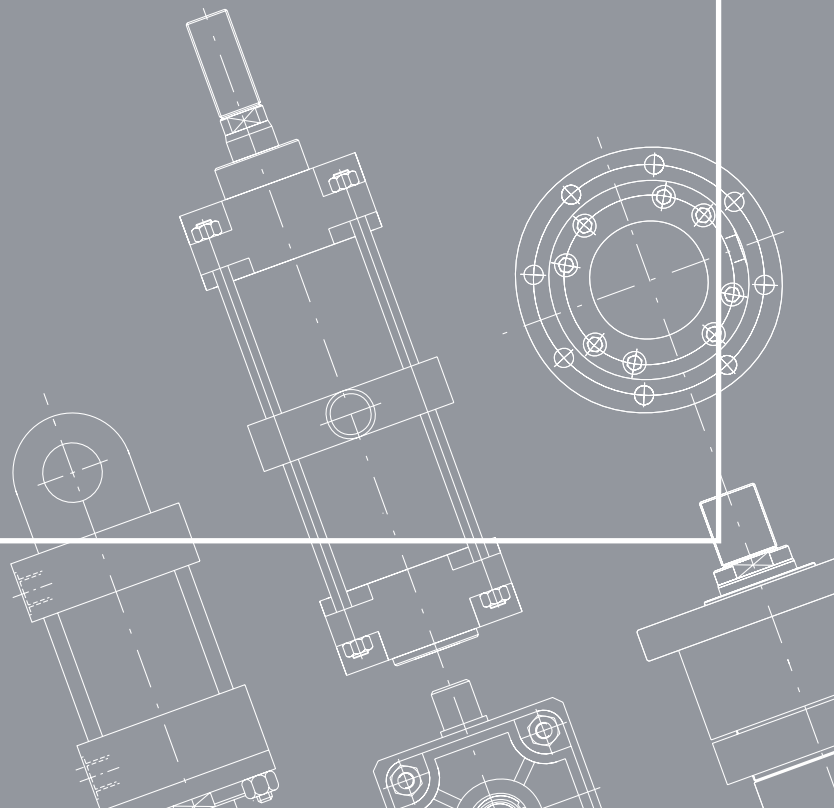

HYDRAULIC CYLINDERS  
I S O 6 0 2 2



## Presentation

The range of CMB 09 series double-acting hydraulic cylinders and servo-cylinders has been developed to specifically meet the most demanding drive unit requirements of the iron and steel industry in accordance with ISO 6022 and DIN 24333 construction standards.

The compact construction with round heads, the care taken in choosing the materials and seals used, combined with strict final testing which reproduces the cylinders' normal working conditions, make these hydraulic actuators the very best offered by technology in the field of hydraulic drive units for all types of industrial applications, in particular for critical requirements such as those of the iron and steel sector which require strong, reliable and easily-maintained products.

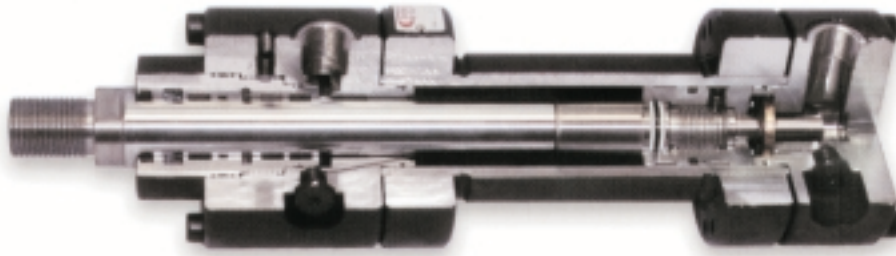

## Technical features

- **Interchangeable dimensions:** in accordance with standard ISO 6022 and DIN 24333
- **Nominal working pressure (continuous service):** 250 bar (25 MPa)
- **Maximum working pressure:** 320 bar (32 MPa)
- **Bores available:** from 50 to 400 mm including N° 2 bores non-compliant with ISO 6022 standard
- **Rod diameters:** 2 diameters depending on the bore are available from 32 to 280 mm which enable the following cross-section ratios to be obtained:
  - a) 1:1,65 reduced-size rod
  - b) 1:2 normal rod
- **Rod material:** high-resistance, hardened and tempered steel alloy, chromed and honed with a rugosity of  $R_a = 0,2 \mu\text{m}$ . On request the rod can be constructed using induction tempering heat treatment, in stainless steel or with Ni-Cr surface treatment
- **Stroke:** on request from the customer with dimensional tolerances from 0 to 1 mm for sizes up to 1000 mm and from 0 to 4 mm up to 6000 mm
- **Coupling connections:** produced as standard with BSP screw-threaded cylindrical connections and housing for sealing washers according to ISO 1179; on request SAE flange coupling in accordance with DIN 3852-2
- **Standard maximum speed:** 0.5 m/s
- **Standard temperature:** from  $-20 \text{ }^\circ\text{C}$  to  $+100 \text{ }^\circ\text{C}$
- **Standard hydraulic fluid:** mineral oil in accordance with ISO 6743/4 - 1982 standard with degree of purity in compliance with ISO 4406 standard
- **Mountings and accessories available:** 5 different types of standard mounting compliant with ISO standards and 2 non-compliant completed by a range of accessories for connecting to the rod end

## How to order a CMB 09 series cylinder compliant with ISO 6022

The CMB 09 series cylinders compliant with ISO 6022 standards are provided with an identification code which describes the construction specifications in a non-ambiguous way.

To make up the code for the order, follow the code diagram set out below and insert the letters identifying the various features of the desired cylinder in the sequence given below.

Features	Description	Code
<b>Series</b>	To ISO 6022 standards	<b>09</b>
<b>Bore</b>	To ISO 6022 standards for taking transducer	<b>T9</b>
<b>Bore</b>	Specify bore in mm (indicate 3 figures)	-
<b>Rod</b>	Rod diameter 32 mm (bore 50)	<b>I</b>
	Rod diameter 36 mm (bore 50)	<b>L</b>
	Rod diameter 40 mm (bore 63)	<b>O</b>
	Rod diameter 45 mm (bore 63)	<b>M</b>
	Rod diameter 50 mm (bore 80)	<b>N</b>
	Rod diameter 56 mm (bore 80)	<b>P</b>
	Rod diameter 63 mm (bore 100)	<b>Q</b>
	Rod diameter 70 mm (bore 100)	<b>R</b>
	Rod diameter 80 mm (bore 125)	<b>S</b>
	Rod diameter 90 mm (bores 125 and 140 <sup>1</sup> )	<b>T</b>
	Rod diameter 100 mm (bores 140 <sup>1</sup> and 160)	<b>U</b>
	Rod diameter 110 mm (bores 160 and 180 <sup>1</sup> )	<b>V</b>
	Rod diameter 125 mm (bores 180 <sup>1</sup> and 200)	<b>A</b>
	Rod diameter 140 mm (bore 200)	<b>Z</b>
	Rod diameter 160 mm (bore 250)	<b>B</b>
	Rod diameter 180 mm (bore 250)	<b>X</b>
	Rod diameter 200 mm (bore 320)	<b>C</b>
Rod diameter 220 mm (bore 320)	<b>Y</b>	
Rod diameter 250 mm (bore 400)	<b>D</b>	
Rod diameter 280 mm (bore 400)	<b>W</b>	
<b>Stroke</b>	Specify the stroke in mm (indicate 4 figures)	-
<b>Rod type</b>	Without cushioning	<b>C</b>
	Front cushioning	<b>E</b>
	Rear cushioning <sup>!!</sup>	<b>G</b>
	Cushioning on both ends <sup>!!</sup>	<b>P</b>
	Double rod without cushioning	<b>S</b>
Double rod with cushioning	<b>T</b>	
<b>Special machining</b>	Female rod threading	<b>w</b>
	Customised machining	<b>z</b>
<b>Mounting type</b>	Basic version (not in line to ISO 6022)	<b>00</b>
	Side foot (not in line to ISO 6022)	<b>03</b>
	Intermediate fixed trunnion (ISO MT4)	<b>06</b>
	Rear clevis (ISO MP3)	<b>07</b>
	Rear spherical bearing (ISO MP5)	<b>08</b>
	Front flange (ISO MF3)	<b>13</b>
Rear flange (ISO MF4)	<b>14</b>	

<sup>1</sup> Bore non-compliant with ISO 6022 standard  
<sup>!!</sup> Not available for bores 50 and 63 of the T9 series

Example of cylinder code: **09063M0125E13**

09 series cylinder to ISO 6022 standards - bore 63 - rod 45 - stroke 125 - front cushioning - front flange (ISO MF3). The input connection and front cushioning positions are standard so they are not specified in the ordering code (oil feeding inlets side 1 on head and cap, cushioning side 3 on head as specified in Table 13 on page 36).

Example of cylinder code: **09125T0800Pw06/FU P14 K22**

09 series cylinder to ISO 6022 standards - bore 125 - rod 90 - stroke 800 - cushioning on both ends - female rod threading - intermediate fixed trunnion (ISO MT4) - front and rear inductive sensor - low friction seals - position of input connections side 1 on head and side 4 on cap - position of inductive sensor side 2 on head and cap - cushioning in standard position side 3 on head and cap (see Table 13 on page 36).

CMB S.r.l. as part of the continuous refining and development of its products, reserve the right to modify the contents of the following catalogue and the technical specifications of its products without any prior warning. Reproduction, even partial, of any texts and illustrations may only be made upon our explicit authorisation.

When issuing the order for the cylinder, provide the following information:

- code identifying the model
- quantity
- special features (if requested) with any enclosed sketches and/or construction drawings
- operating conditions for special uses
- delivery date with type of priority

Code	Description	Features
<b>D0</b>	Specify the position of the drainage connection	<b>Drainage connection</b>
<b>K00</b>	Specify the position of the front and rear inductive sensors	<b>Position of inductive sensors</b>
<b>S00</b>	Specify the position of the front and rear air bleeds	<b>Position of air bleeds</b>
<b>R00</b>	Specify the position of the front and rear braking adjustment devices	<b>Position of braking adjustment devices</b>
<b>P00</b>	Specify the position of front and rear connections	<b>Position of connections</b>
-	Specify the number of spacers (multiples of 50 mm)	<b>Spacers</b>
<b>T</b>	Seals for water and glycol mixtures	<b>Seals</b>
<b>U*</b>	Low friction seals	
<b>V**</b>	Seals for high temperatures and/or aggressive fluids	
<b>Z</b>	Seals for heavy applications	
<b>D*</b>	Front inductive sensor	<b>Inductive sensors</b>
<b>E*</b>	Rear inductive sensor	
<b>F*</b>	Front and rear inductive sensor	
<b>A</b>	Front air bleed	<b>Air bleeds</b>
<b>B</b>	Rear air bleed	
<b>C<sup>Δ</sup></b>	Front and rear air bleeds	

\* Minimum working pressure: 20 bar  
 \*\* Maximum working temperature for T9 and 09 series cylinders fitted with inductive sensors: 70 °C  
 • Using inductive sensors, the cylinder must be provided with cushioning (front or rear)  
 Δ Compulsory for T9 series cylinders

## Seals and hydraulic fluids

The working limits of the mixes used to produce the seals installed in the rod guide bush, piston and cylinder tube are given in the chart below in relation to the hydraulic fluid used, temperature, speed and minimum working pressure. Standard seals may work at a temperature of between -20 °C and +100 °C inclusive.

When particular working conditions are required, in which temperatures exceed these limits, CMB offers special high-temperature seals.

Should hydraulic fluids with a water and glycol mixtures or special fluid base be used, specially designed seals are available.

For applications in which low friction coefficients and the absence of stick-slip are required, low friction seals can be supplied.

Chevron-type seals suitable for heavy applications, are available for the requirements of the iron and steel industry. Please indicate the identification code (omit if standard) of the type of mix required for the seals in the order code given on page 2.

On request, special type seals are available for uses not covered by the chart below and guide rings for high radial loads.

For further information, contact our Technical Department.

Code	Description	Seals material	Hydraulic fluid (standards ISO 6743/4-1982)	Minimum pressure	Temperature range	Maximum speed
	Standard	Nitrile rubber (NBR), Polyurethane (AU), Charged bronze PTFE	Mineral oil HH, HL, HLP, HLPD and HM	10 bar	from -20 °C to +100 °C	0,5 m/s
<b>T</b>	Water and glycol mixtures	Nitrile rubber (NBR), Charged bronze PTFE	Water and glycol mixtures (HFC)	10 bar	from -20 °C to +85 °C	0,5 m/s
<b>U</b>	Low friction	Nitrile rubber (NBR), Charged bronze PTFE	HH, HL, HLP, HLPD, HM mineral oil and water and glycol mixtures (HFC)	20 bar	from -20 °C to +100 °C	15 m/s
<b>V</b>	High temperature and/or aggressive fluids	Fluoroelastomer (FKM), Charged bronze PTFE	Non-flammable hydraulic fluids with phosphoric ester base (HFD-R), high temperature hydraulic oil and/or environments with temperatures over 100 °C. Special hydraulic fluids.	10 bar	from -20 °C to +150 °C	1 m/s
<b>Z</b>	Heavy application	Nitrile rubber (NBR), Polyurethane (AU), Charged nitrile rubber cotton fabric	Mineral oil HH, HL, HLP, HLPD and HM	10 bar	from -20 °C to +150 °C	0,5 m/s

## Mountings choice for the 09 series

The complete range of ISO 6022 09 series cylinders manufactured by CMB offers 7 different mounting types capable of meeting most working requirements. On the following pages the general criteria to be used in choosing the type and space requirements of the mounting types for single rod and double rod cylinders with their corresponding accessories are described.

As regards special applications, our Technical Department is at your complete disposal for the construction of cylinders to particular requirements.

## Main categories of mounting types

**Side foot mounting**

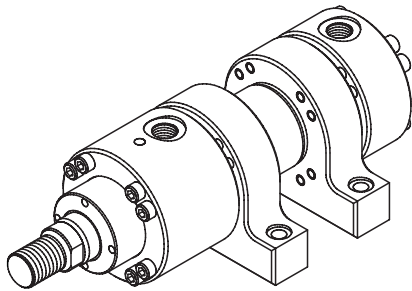

**End mounting**

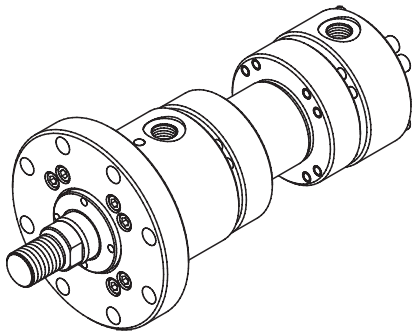

**Trunnion mounting**

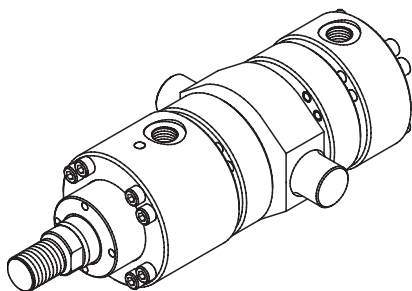

**Pivot mounting**

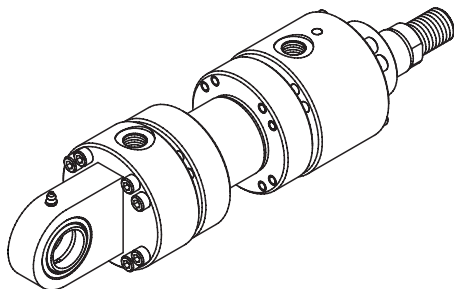

## Side foot mounting

Cylinders with side foot mounting do not absorb loads around the rod axis and consequently the thrust generated by the cylinder creates a torque that tends to make it rotate around the bolting screws.

With this mounting type, stable support and effective guiding of the load must be guaranteed to reduce as far as possible the weight bearing down on the guide bush.

This mounting type is available in just one construction shape which is identified by the code **03 (not in line to ISO 6022)** and should be used exclusively in cases in which the cylinder stroke measures at least half of bore or where working pressure is lower than 160 bar.

## End mounting

This mounting type is indicated for cylinders that transmit power along their own axis and are therefore suitable for moving loads in a straight line.

It is available in two different construction shapes which are identified by the following codes:

**01 - Front flange (ISO MF3)**

**02 - Rear flange (ISO MF4)**

The choice amongst the different types of mounting available depends not only on the overall dimensions but also on the direction of the reaction force generated on the support according to whether the cylinder works by pushing or pulling.

## Hinge mounting

Cylinders with hinge mounting are suitable for both pushing and pulling applications in which the load to be moved follows a curvilinear course which enables the forces around its own axis to be absorbed.

Two forms of construction are available for the version with rear hinge and one for the oscillating version, which can be identified by the following codes:

**Pivot mounting**

**07 - Rear clevis (ISO MP3)**

**08 - Rear spherical bearing (ISO MP5)**

**Trunnion mounting**

**06 - Intermediate fixed trunnion (ISO MT4)**

## Double rod cylinders mounting

Double rod cylinders are available for all mounting types except for the following versions:

**07 - Rear clevis (ISO MP3)**

**08 - Rear spherical bearing (ISO MP5)**

# ISO 6022 09 Series

## Type 00 (Not to ISO standards)

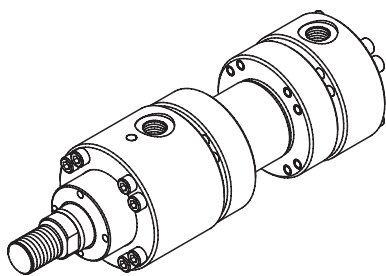

## Basic version

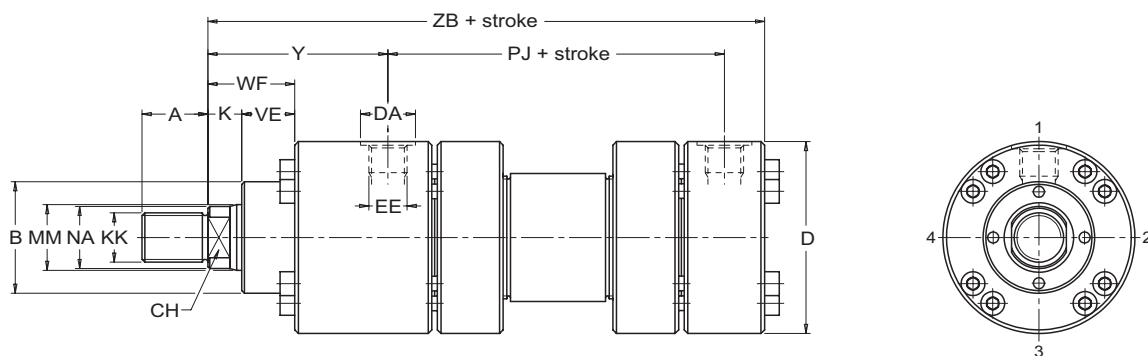

Bore Ø	MM Ø	A	B <sup>f8</sup> Ø	CH	D <sub>max</sub> Ø	EE (BSP)	DA Ø	KK (Metric)	NA Ø	K	VE	WF	Y	PJ	ZB <sub>max</sub>
50	32	36	63	28	105	1/2"	30	M27x2	31	18	29	47	98	120	244
	36			35											
63	40	45	75	34	122	3/4"	37	M33x2	38	21	32	53	112	133	274
	45			43											
80	50	56	90	43	145	3/4"	37	M42x2	48	24	36	60	120	155	305
	56			54											
100	63	63	110	53	175	1"	47	M48x2	60	27	41	68	134	171	340
	70			67											
125	80	85	132	65	210	1"	47	M64x3	77	31	45	76	153	205	396
	90			87											
140 <sup>!</sup>	90	90	145	75	255	1" 1/4	54	M72x3	87	31	45	76	181	208	430
	100			96											
160	100	95	160	85	270	1" 1/4	54	M80x3	96	35	50	85	185	235	467
	110			106											
180 <sup>!</sup>	110	105	185	95	315	1" 1/4	54	M90x3	106	40	55	95	205	250	505
	125			121											
200	125	112	200	-	330	1" 1/4	54	M100x3	121	40	61	101	220	278	550
	140			136											
250	160	125	250	-	410	1" 1/2	61	M125x4	155	42	71	113	260	325	652
	180			175											
320	200	160	320	-	510	2"	75	M160x4	195	48	88	136	310	350	764
	220			214											
400	250	200	400	-	628	2"	75	M200x4	242	53	110	163	310	355	775
	280			270											

! Bore non-compliant with ISO 6022 standard.

Unless otherwise specified, all dimensions are given in millimetres.

## Side foot

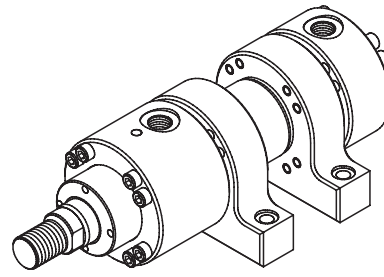

# Type 03

(Not to ISO standards)

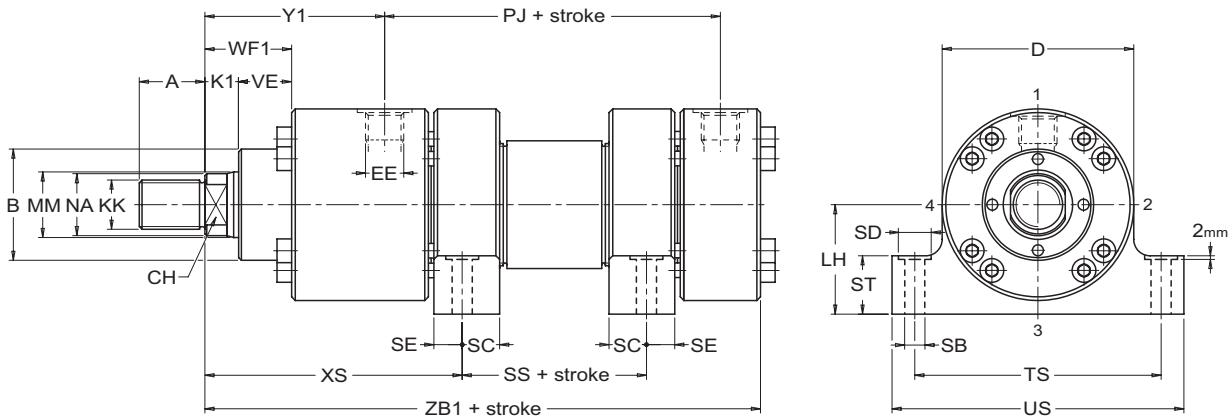

Bore Ø	MM Ø	A	B <sup>f8</sup> Ø	CH	D <sub>max</sub> Ø	EE (BSP)	KK (Metric)	NA Ø	K1	VE	WF1	LH <sup>h10</sup>	SB <sup>H13</sup> Ø	SD Ø	SC	SE	ST	TS	US	XS	Y1	SS	PJ	ZB1 <sub>max</sub>
50	32	36	63	28	105	1/2"	M27x2	31	18	29	47	60	11	18	20,5*	15,5	32	135	160	130	98	55	120	244
	36			35																				
63	40	45	75	34	122	3/4"	M33x2	38	19	32	51	68	13,5	20	24,5*	17,5	37	155	185	147,5	110	55	133	272
	45			43																				
80	50	56	90	43	145	3/4"	M42x2	48	24	36	60	80	17,5	26	22,5	22,5	42	185	225	170,5	120	55	155	305
	56			54																				
100	63	63	110	53	175	1"	M48x2	60	27	41	68	95	22	33	27,5	27,5	52	220	265	192,5	134	55	171	340
	70			67																				
125	80	85	132	65	210	1"	M64x3	77	31	45	76	115	26	40	30	30	62	270	325	230	153	60	205	396
	90			87																				
140 <sup>!</sup>	90	90	145	75	255	1" 1/4	M72x3	87	31	45	76	135	30	48	35,5	35,5	77	325	390	254,5	181	61	208	430
	100			96																				
160	100	95	160	85	270	1" 1/4	M80x3	96	38	50	88	145	33	48	37,5	37,5	77	340	405	265,5	188	79	235	470
	110			106																				
180 <sup>!</sup>	110	105	185	95	315	1" 1/4	M90x3	106	40	55	95	165	40	60	42,5	42,5	87	390	465	287,5	205	85	250	505
	125			121																				
200	125	112	200	-	330	1" 1/4	M100x3	121	40	61	101	170	40	60	47*	45	87	405	480	315	220	90	278	550
	140			136																				
250	160	125	250	-	410	1" 1/2	M125x4	155	48	71	119	215	52	76	52*	50	112	520	620	360	266	120	325	658
	180			175																				
320	200	160	320	-	510	2"	M160x4	195	48	88	136	260	62	110	62*	60	152	620	740	425	310	120	350	764
	220			214																				
400	250	200	400	-	628	2"	M200x4	242	53	110	163	320	80	120	75	75	170	760	900	455	310	91	355	775
	280			270																				

! Bore non-compliant with ISO 6022 standard.

\* Mounting holes offset from centre line.

Unless otherwise specified, all dimensions are given in millimetres.

# ISO 6022 09 Series

## Type 06 (ISO MT4)

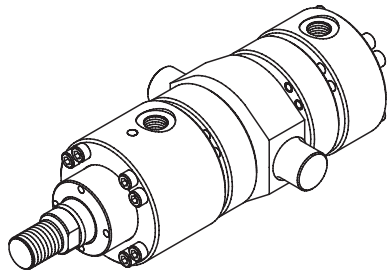

## Intermediate fixed trunnion

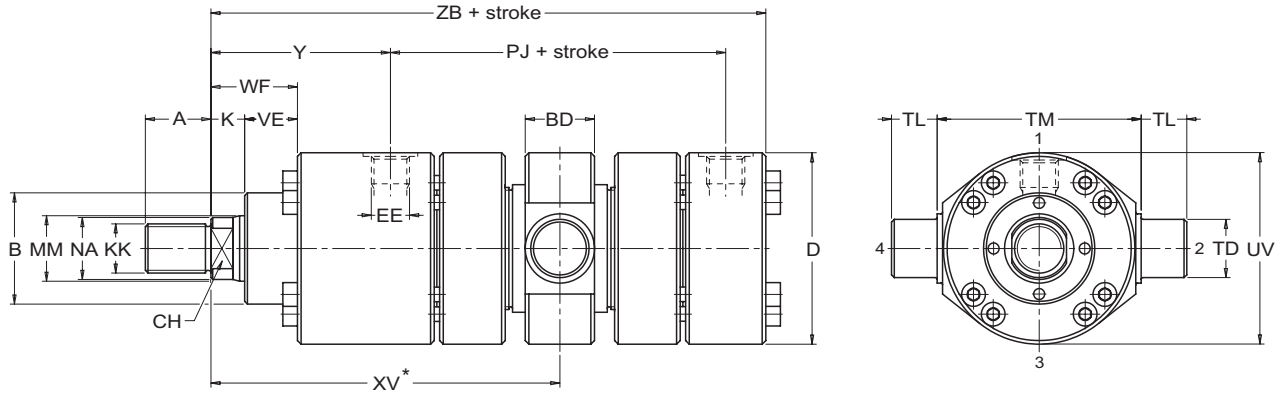

Bore Ø	MM Ø	A	B <sup>f8</sup> Ø	CH	D <sub>max</sub> Ø	EE (BSP)	KK (Metric)	NA Ø	K	VE	WF	BD	TD <sup>f8</sup> Ø	TL	TM <sup>h13</sup>	UV Ø	XV minimum	XV+stroke maximum	Y	PJ	ZB <sub>max</sub>	Stroke minimum
50	32	36	63	28	105	1/2"	M27x2	31	18	29	47	38	32	25	112	105	180	144	98	120	244	45
	36			35																		
63	40	45	75	34	122	3/4"	M33x2	38	21	32	53	48	40	32	125	122	195	160	112	133	274	45
	45			43																		
80	50	56	90	43	145	3/4"	M42x2	48	24	36	60	58	50	40	150	145	220	175	120	155	305	60
	56			46																		
100	63	63	110	53	175	1"	M48x2	60	27	41	68	73	63	50	180	175	245	185	134	171	340	80
	70			60																		
125	80	85	132	65	210	1"	M64x3	77	31	45	76	88	80	63	224	210	290	220	153	205	396	95
	90			75																		
140 <sup>!</sup>	90	90	145	75	255	1" 1/4	M72x3	87	31	45	76	98	90	70	265	255	330	240	181	208	430	115
	100			85																		
160	100	95	160	85	270	1" 1/4	M80x3	96	35	50	85	108	100	80	280	270	340	255	185	235	467	115
	110			95																		
180 <sup>!</sup>	110	105	185	95	315	1" 1/4	M90x3	106	40	55	95	118	110	90	320	315	390	270	205	250	505	150
	125			-																		
200	125	112	200	-	330	1" 1/4	M100x3	121	40	61	101	133	125	100	335	330	430	280	220	278	550	180
	140			136																		
250	160	125	250	-	410	1" 1/2	M125x4	155	42	71	113	180	160	125	425	410	505	320	260	325	652	220
	180			175																		
320	200	160	320	-	510	2"	M160x4	195	48	88	136	220	200	160	530	510	590	380	310	350	764	260
	220			214																		
400	250	200	400	-	628	2"	M200x4	242	53	110	163	270	250	200	630	628	630	340	310	355	775	340
	280			270																		

! Bore non-compliant with ISO 6022 standard.

\* Specify the dimension in case of order.

Unless otherwise specified, all dimensions are given in millimetres.

## Rear clevis

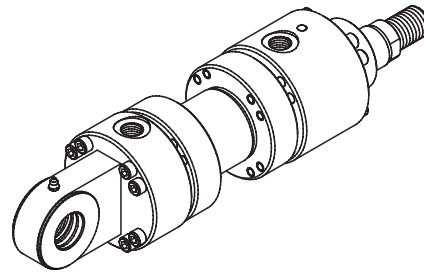

# Type 07

(ISO MP3)

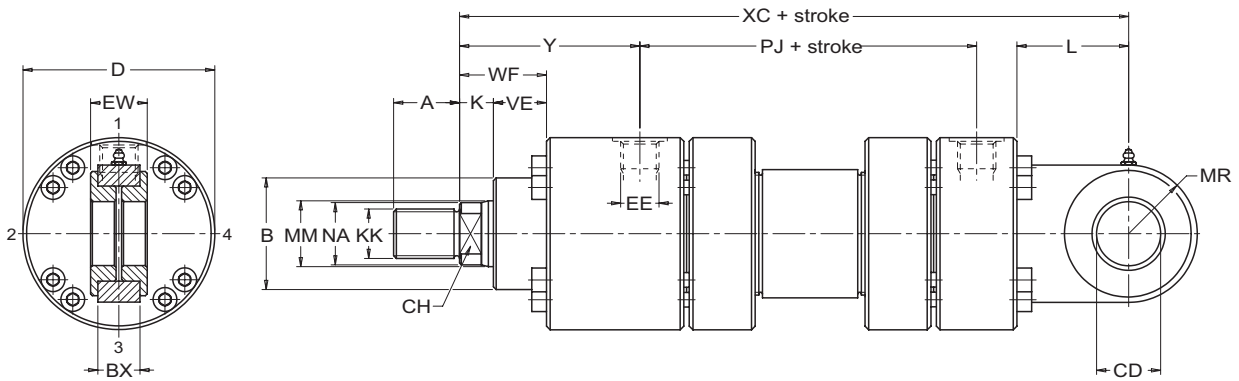

Bore Ø	MM Ø	A	B <sup>f8</sup> Ø	CH	D <sub>max</sub> Ø	EE (BSP)	KK (Metric)	NA Ø	K	VE	WF	BX	CD <sup>H9</sup> Ø	EW <sup>h12</sup>	L	MR <sub>max</sub>	XC	Y	PJ
50	32	36	63	28	105	1/2"	M27x2	31	18	29	47	27	32	32	61	35	305	98	120
	36			35															
63	40	45	75	34	122	3/4"	M33x2	38	21	32	53	35	40	40	74	50	348	112	133
	45			43															
80	50	56	90	43	145	3/4"	M42x2	48	24	36	60	40	50	50	90	61,5	395	120	155
	56			54															
100	63	70	110	53	175	1"	M48x2	60	27	41	68	50	63	63	102	72,5	442	134	171
	70			67															
125	80	90	132	65	210	1"	M64x3	77	31	45	76	60	80	80	124	90	520	153	205
	90			87															
140 <sup>!</sup>	90	100	145	75	255	1" 1/4	M72x3	87	31	45	76	65	90	90	150	113	580	181	208
	100			96															
160	100	110	160	85	270	1" 1/4	M80x3	96	35	50	85	70	100	100	150	125	617	185	235
	110			106															
180 <sup>!</sup>	110	125	185	95	315	1" 1/4	M90x3	106	40	55	95	80	110	110	185	147,5	690	205	250
	125			121															
200	125	140	200	-	330	1" 1/4	M100x3	121	40	61	101	102	125	125	206	160	756	220	278
	140			136															
250	160	180	250	-	410	1" 1/2	M125x4	155	42	71	113	130	160	160	251	200	903	260	325
	180			175															
320	200	220	320	-	510	2"	M160x4	195	48	88	136	162	200	200	316	250	1080	310	350
	220			214															
400	250	280	400	-	628	2"	M200x4	242	53	110	163	192	250	250	300	320	1075	310	355
	280			270															

! Bore non-compliant with ISO 6022 standard.

Unless otherwise specified, all dimensions are given in millimetres.



# ISO 6022 09 Series

## Type 08 (ISO MP5)

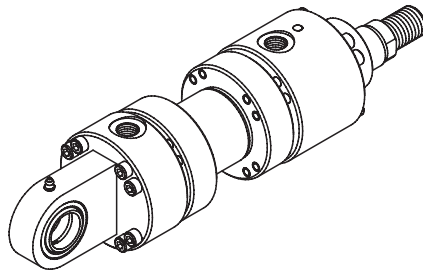

## Rear spherical bearing

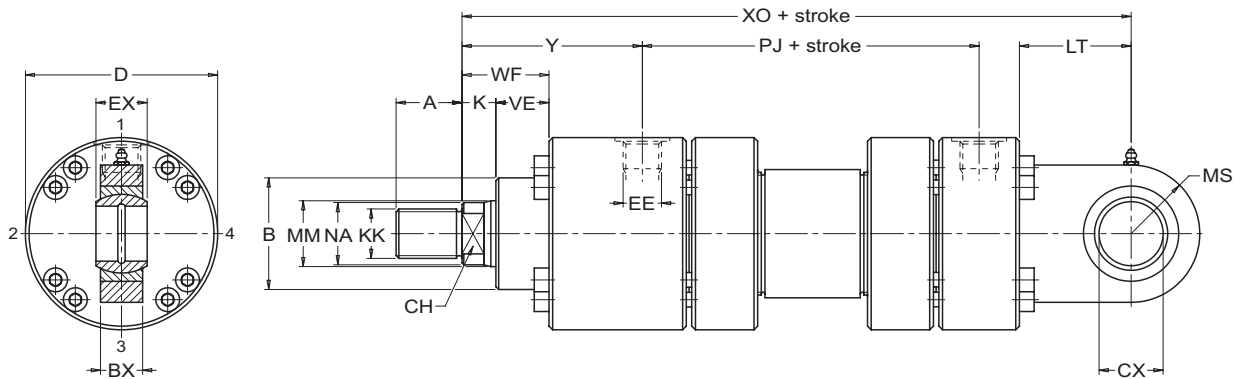

Bore Ø	MM Ø	A	B <sup>f8</sup> Ø	CH	D <sub>max</sub> Ø	EE (BSP)	KK (Metric)	NA Ø	K	VE	WF	BX	CX <sup>H9</sup> Ø	EX <sup>h12</sup>	LT	MS <sub>max</sub>	XO	Y	PJ
50	32	36	63	28	105	1/2"	M27x2	31	18	29	47	27	32	32	61	35	305	98	120
	36			35															
63	40	45	75	34	122	3/4"	M33x2	38	21	32	53	35	40	40	74	50	348	112	133
	45			43															
80	50	56	90	43	145	3/4"	M42x2	48	24	36	60	40	50	50	90	61,5	395	120	155
	56			54															
100	63	63	110	53	175	1"	M48x2	60	27	41	68	50	63	63	102	72,5	442	134	171
	70			67															
125	80	85	132	65	210	1"	M64x3	77	31	45	76	60	80	80	124	90	520	153	205
	90			87															
140 <sup>!</sup>	90	90	145	75	255	1" 1/4	M72x3	87	31	45	76	65	90	90	150	113	580	181	208
	100			96															
160	100	95	160	85	270	1" 1/4	M80x3	96	35	50	85	70	100	100	150	125	617	185	235
	110			106															
180 <sup>!</sup>	110	105	185	95	315	1" 1/4	M90x3	106	40	55	95	80	110	110	185	147,5	690	205	250
	125			121															
200	125	112	200	-	330	1" 1/4	M100x3	121	40	61	101	102	125	125	206	160	756	220	278
	140			136															
250	160	125	250	-	410	1" 1/2	M125x4	155	42	71	113	130	160	160	251	200	903	260	325
	180			175															
320	200	160	320	-	510	2"	M160x4	195	48	88	136	162	200	200	316	250	1080	310	350
	220			214															
400	250	200	400	-	628	2"	M200x4	242	53	110	163	192	250	250	300	320	1075	310	355
	280			270															

! Bore non-compliant with ISO 6022 standard.

Unless otherwise specified, all dimensions are given in millimetres.

## Front flange

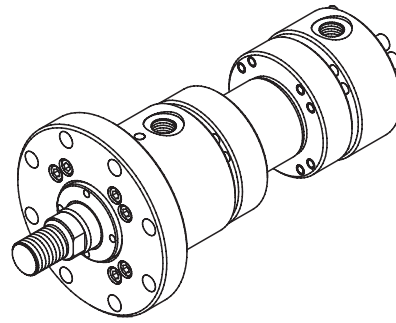

# Type 13

(ISO MF3)

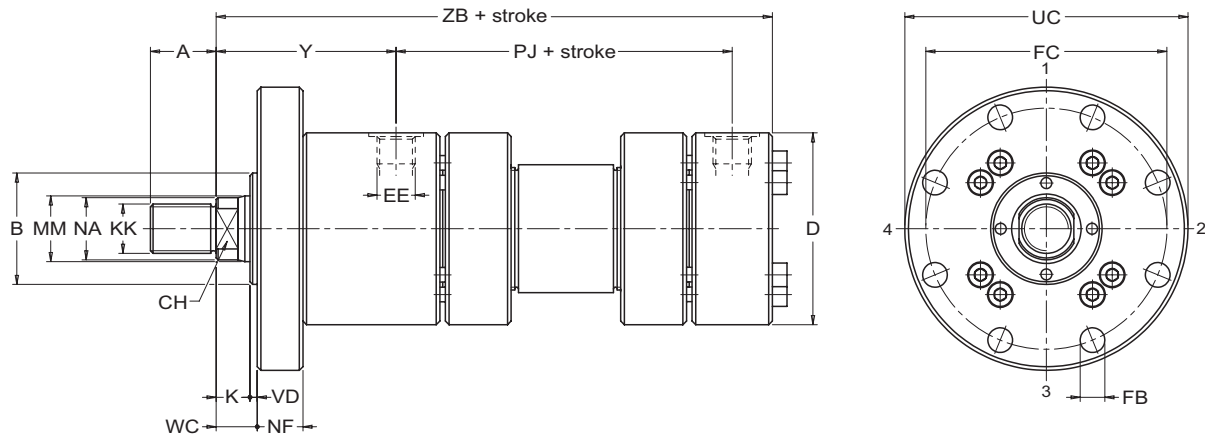

Bore Ø	MM Ø	A	B <sup>f8</sup> Ø	CH	D <sub>max</sub> Ø	EE (BSP)	KK (Metric)	NA Ø	K	VD	WC	NF	FB Ø	FC Ø	UC Ø	Y	PJ	ZB <sub>max</sub>
50	32	36	28	63	105	1/2"	M27x2	31	18	4	22	25	13,5 N° 8 holes	132	155	98	120	244
	36		35															
63	40	45	34	75	122	3/4"	M33x2	38	21	4	25	28	13,5 N° 8 holes	150	175	112	133	274
	45		43															
80	50	56	43	90	145	3/4"	M42x2	48	24	4	28	32	17,5 N° 8 holes	180	210	120	155	305
	56		54															
100	63	63	53	110	175	1"	M48x2	60	27	5	32	36	22 N° 8 holes	212	250	134	171	340
	70		67															
125	80	85	65	132	210	1"	M64x3	77	31	5	36	40	22 N° 8 holes	250	290	153	205	396
	90		87															
140 <sup>!</sup>	90	90	75	145	255	1" 1/4	M72x3	87	31	5	36	40	26 N° 8 holes	300	340	181	208	430
	100		96															
160	100	95	85	160	270	1" 1/4	M80x3	96	35	5	40	45	26 N° 8 holes	315	360	185	235	467
	110		106															
180 <sup>!</sup>	110	105	95	185	315	1" 1/4	M90x3	106	40	5	45	50	33 N° 8 holes	365	420	205	250	505
	125		121															
200	125	112	-	200	330	1" 1/4	M100x3	121	40	5	45	56	33 N° 8 holes	385	440	220	278	550
	140		136															
250	160	125	-	250	410	1" 1/2	M125x4	155	42	8	50	63	39 N° 8 holes	475	540	260	325	652
	180		175															
320	200	160	-	320	510	2"	M160x4	195	48	8	56	80	45 N° 8 holes	600	675	310	350	764
	220		214															
400	250	200	-	400	628	2"	M200x4	242	53	10	63	100	45 N° 12 holes	720	800	310	355	775
	280		270															

! Bore non-compliant with ISO 6022 standard.

Unless otherwise specified, all dimensions are given in millimetres.

## Type 14 (ISO MF4)

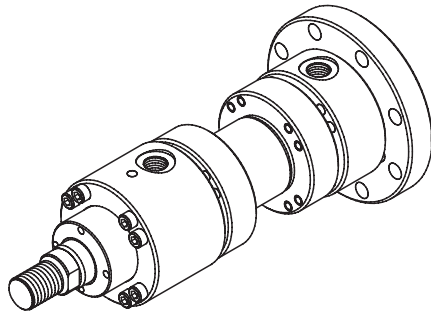

## Rear flange

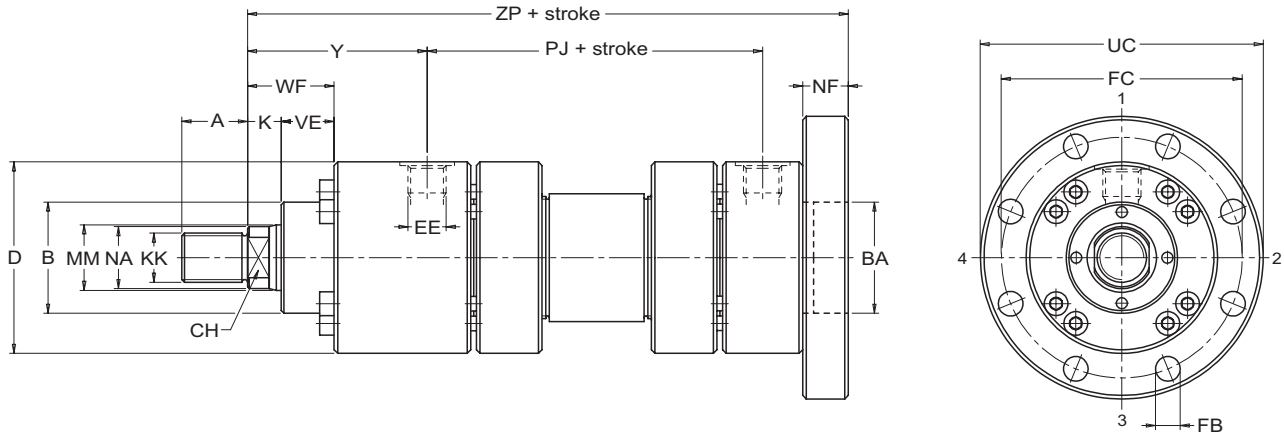

Bore Ø	MM Ø	A	B <sup>FB</sup> Ø	CH	D <sub>max</sub> Ø	EE (BSP)	KK (Metric)	NA Ø	BA <sup>H8</sup> Ø	K	VE	WF	NF	FB Ø	FC Ø	UC Ø	Y	PJ	ZP <sub>max</sub>
50	32	36	63	28	105	1/2"	M27x2	31	63	18	29	47	25	13,5 N° 8 holes	132	155	98	120	265
	36			35															
63	40	45	75	34	122	3/4"	M33x2	38	75	21	32	53	28	13,5 N° 8 holes	150	175	112	133	298
	45			43															
80	50	56	90	43	145	3/4"	M42x2	48	90	24	36	60	32	17,5 N° 8 holes	180	210	120	155	332
	56			54															
100	63	70	110	53	175	1"	M48x2	60	110	27	41	68	36	22 N° 8 holes	212	250	134	171	371
	70			67															
125	80	90	132	65	210	1"	M64x3	77	132	31	45	76	40	22 N° 8 holes	250	290	153	205	430
	90			87															
140 <sup>1</sup>	90	100	145	75	255	1" 1/4	M72x3	87	145	31	45	76	40	26 N° 8 holes	300	340	181	208	465
	100			96															
160	100	110	160	85	270	1" 1/4	M80x3	96	160	35	50	85	45	26 N° 8 holes	315	360	185	235	505
	110			106															
180 <sup>1</sup>	110	125	185	95	315	1" 1/4	M90x3	106	185	40	55	95	50	33 N° 8 holes	365	420	205	250	550
	125			121															
200	125	140	200	-	330	1" 1/4	M100x3	121	200	40	61	101	56	33 N° 8 holes	385	440	220	278	596
	140			136															
250	160	180	250	-	410	1" 1/2	M125x4	155	250	42	71	113	63	39 N° 8 holes	475	540	260	325	703
	180			175															
320	200	220	320	-	510	2"	M160x4	195	320	48	88	136	80	45 N° 8 holes	600	675	310	350	830
	220			214															
400	250	280	400	-	628	2"	M200x4	242	400	53	110	163	100	45 N° 12 holes	720	800	310	355	855
	280			270															

<sup>1</sup> Bore non-compliant with ISO 6022 standard.

Unless otherwise specified, all dimensions are given in millimetres.

## Double rod basic version

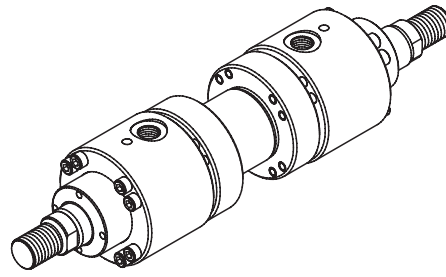

# Type 00

(Not to ISO standards)

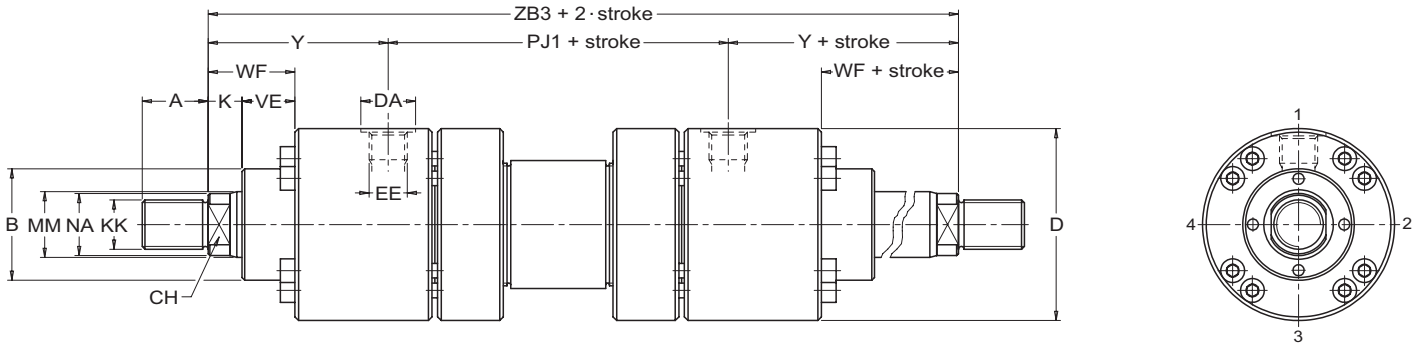

Bore Ø	MM Ø	A	B <sup>f8</sup> Ø	CH	D <sub>max</sub> Ø	EE (BSP)	DA Ø	KK (Metric)	NA Ø	K	VE	WF	Y	PJ1	ZB3
50	32	36	63	28	105	1/2"	30	M27x2	31	18	29	47	98	126	322
	36			35											
63	40	45	75	34	122	3/4"	37	M33x2	38	21	32	53	112	134	358
	45			43											
80	50	56	90	43	145	3/4"	37	M42x2	48	24	36	60	120	153	393
	56			54											
100	63	63	110	53	175	1"	47	M48x2	60	27	41	68	134	165	433
	70			67											
125	80	85	132	65	210	1"	47	M64x3	77	31	45	76	153	204	510
	90			87											
140 <sup>!</sup>	90	90	145	75	255	1" 1/4	54	M72x3	87	31	45	76	181	208	570
	100			96											
160	100	95	160	85	270	1" 1/4	54	M80x3	96	35	50	85	185	225	595
	110			106											
180 <sup>!</sup>	110	105	185	95	315	1" 1/4	54	M90x3	106	40	55	95	205	250	660
	125			121											
200	125	112	200	-	330	1" 1/4	54	M100x3	121	40	61	101	220	271	711
	140			136											
250	160	125	250	-	410	1" 1/2	61	M125x4	155	42	71	113	260	308	828
	180			175											
320	200	160	320	-	510	2"	75	M160x4	195	48	88	136	310	350	970
	220			214											
400	250	200	400	-	628	2"	75	M200x4	242	53	110	163	310	355	975
	280			270											

! Bore non-compliant with ISO 6022 standard.

Unless otherwise specified, all dimensions are given in millimetres.

# ISO 6022 09 Series

## Type 03

(Not to ISO standards)

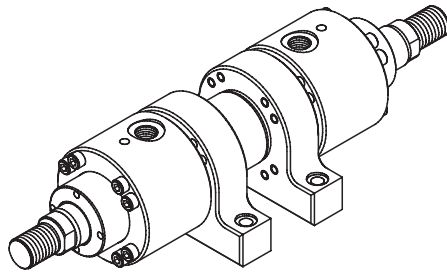

## Double rod side foot

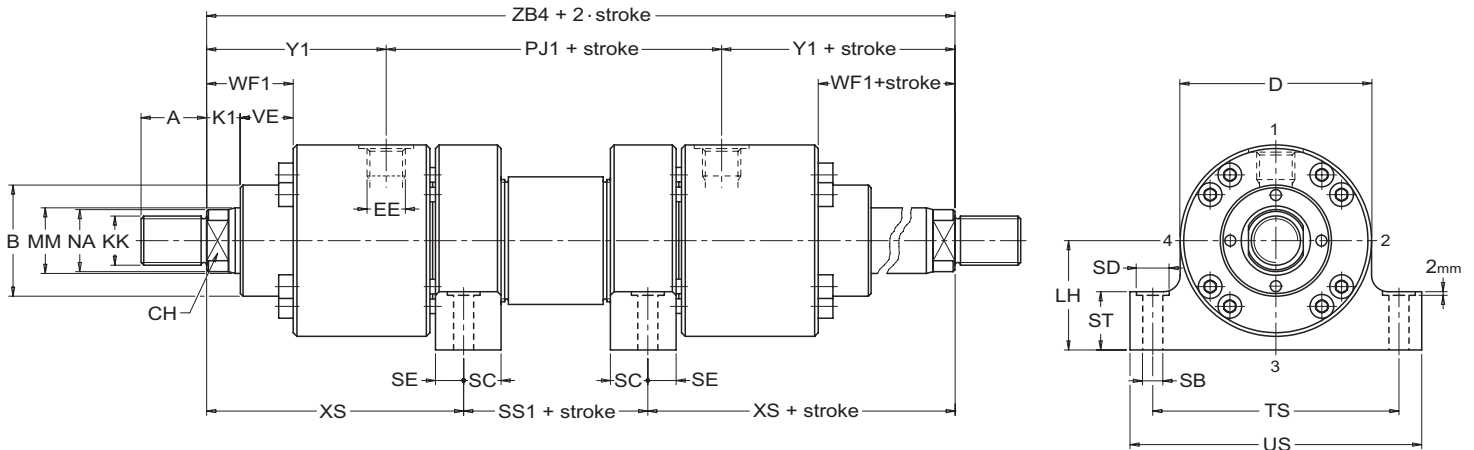

Bore Ø	MM Ø	A	B <sup>f8</sup> Ø	CH	D <sub>max</sub> Ø	EE (BSP)	KK (Metric)	NA Ø	K1	VE	WF1	LH <sup>h10</sup>	SB <sup>H13</sup> Ø	SD Ø	SC	SE	ST	TS	US	XS	Y1	SS1	PJ1	ZB4
50	32	36	63	28	105	1/2"	M27x2	31	18	29	47	60	11	18	20,5*	15,5	32	135	160	130	98	62	126	322
	36			35																				
63	40	45	75	34	122	3/4"	M33x2	38	19	32	51	68	13,5	20	24,5*	17,5	37	155	185	147,5	110	59	134	354
	45			43																				
80	50	56	90	43	145	3/4"	M42x2	48	24	36	60	80	17,5	26	22,5	22,5	42	185	225	170,5	120	48	153	393
	56			54																				
100	63	63	110	53	175	1"	M48x2	60	27	41	68	95	22	33	27,5	27,5	52	220	265	192,5	134	50	165	433
	70			67																				
125	80	85	132	65	210	1"	M64x3	77	31	45	76	115	26	40	30	30	62	270	325	230	153	50	204	510
	90			87																				
140 <sup>!</sup>	90	90	145	75	255	1" 1/4	M72x3	87	31	45	76	135	30	48	35,5	35,5	77	325	390	254,5	181	61	208	570
	100			96																				
160	100	95	160	85	270	1" 1/4	M80x3	96	38	50	88	145	33	48	37,5	37,5	77	340	405	265,5	188	70	225	601
	110			106																				
180 <sup>!</sup>	110	105	185	95	315	1" 1/4	M90x3	106	40	55	95	165	40	60	42,5	42,5	87	390	465	287,5	205	85	250	660
	125			121																				
200	125	112	200	-	330	1" 1/4	M100x3	121	40	61	101	170	40	60	47*	45	87	405	480	315	220	81	271	711
	140			136																				
250	160	125	250	-	410	1" 1/2	M125x4	155	48	71	119	215	52	76	52*	50	112	520	620	360	266	120	308	840
	180			175																				
320	200	160	320	-	510	2"	M160x4	195	48	88	136	260	62	110	62*	60	152	620	740	425	310	120	350	970
	220			214																				
400	250	200	400	-	628	2"	M200x4	242	53	110	163	320	80	120	75	75	170	760	900	455	310	91	355	975
	280			270																				

! Bore non-compliant with ISO 6022 standard.

\* Mounting holes offset from centre line.

Unless otherwise specified, all dimensions are given in millimetres.

## Double rod intermediate fixed trunnion

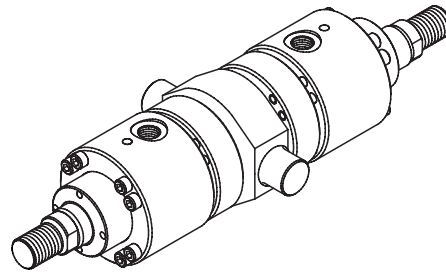

## Type 06 (ISO MT4)

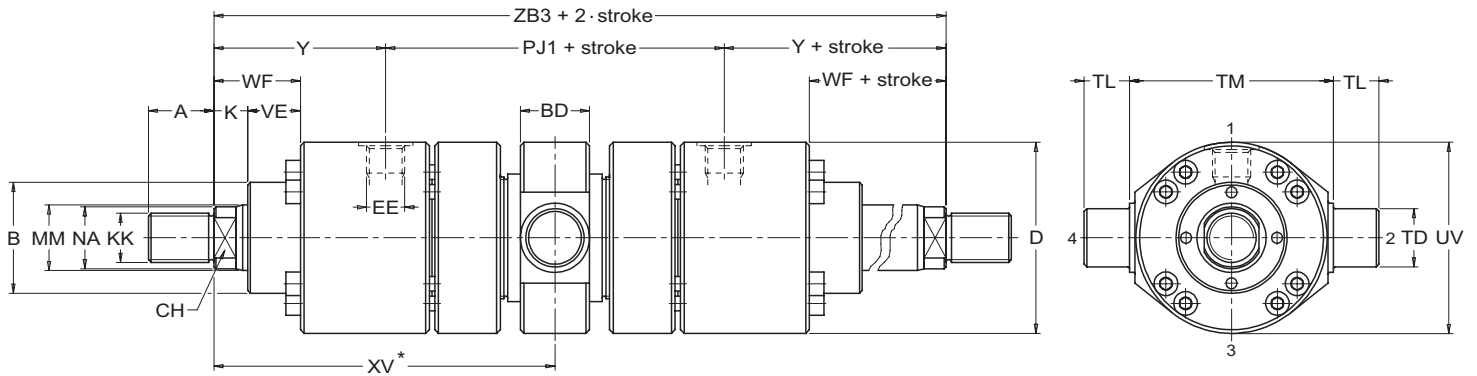

Bore Ø	MM Ø	A	B <sup>f8</sup> Ø	CH	D <sub>max</sub> Ø	EE (BSP)	KK (Metric)	NA Ø	K	VE	WF	BD	TD <sup>f8</sup> Ø	TL	TM <sup>h13</sup>	UV Ø	XV minimum	XV+stroke maximum	Y	PJ1	ZB3	Stroke minimum
50	32	36	63	28	105	1/2"	M27x2	31	18	29	47	38	32	25	112	105	180	144	98	126	322	45
	36			35																		
63	40	45	75	34	122	3/4"	M33x2	38	21	32	53	48	40	32	125	122	195	160	112	134	358	45
	45			43																		
80	50	56	90	43	145	3/4"	M42x2	48	24	36	60	58	50	40	150	145	220	175	120	153	393	60
	56			46																		
100	63	63	110	53	175	1"	M48x2	60	27	41	68	73	63	50	180	175	245	185	134	165	433	80
	70			60																		
125	80	85	132	65	210	1"	M64x3	77	31	45	76	88	80	63	224	210	290	220	153	204	510	95
	90			75																		
140 <sup>!</sup>	90	90	145	75	255	1" 1/4	M72x3	87	31	45	76	98	90	70	265	255	330	240	181	208	570	115
	100			85																		
160	100	95	160	85	270	1" 1/4	M80x3	96	35	50	85	108	100	80	280	270	340	255	185	225	595	115
	110			95																		
180 <sup>!</sup>	110	105	185	95	315	1" 1/4	M90x3	106	40	55	95	118	110	90	320	315	390	270	205	250	660	150
	125			-																		
200	125	112	200	-	330	1" 1/4	M100x3	121	40	61	101	133	125	100	335	330	430	280	220	271	711	180
	140			136																		
250	160	125	250	-	410	1" 1/2	M125x4	155	42	71	113	180	160	125	425	410	505	320	260	308	828	220
	180			175																		
320	200	160	320	-	510	2"	M160x4	195	48	88	136	220	200	160	530	510	590	380	310	350	970	260
	220			214																		
400	250	200	400	-	628	2"	M200x4	242	53	110	163	270	250	200	630	628	630	340	310	355	975	340
	280			270																		

! Bore non-compliant with ISO 6022 standard.

\* Specify the dimension in case of order.

Unless otherwise specified, all dimensions are given in millimetres.

# ISO 6022 09 Series

## Type 13 (ISO MF3)

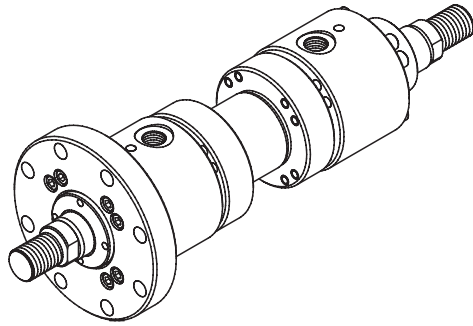

Double rod  
front flange

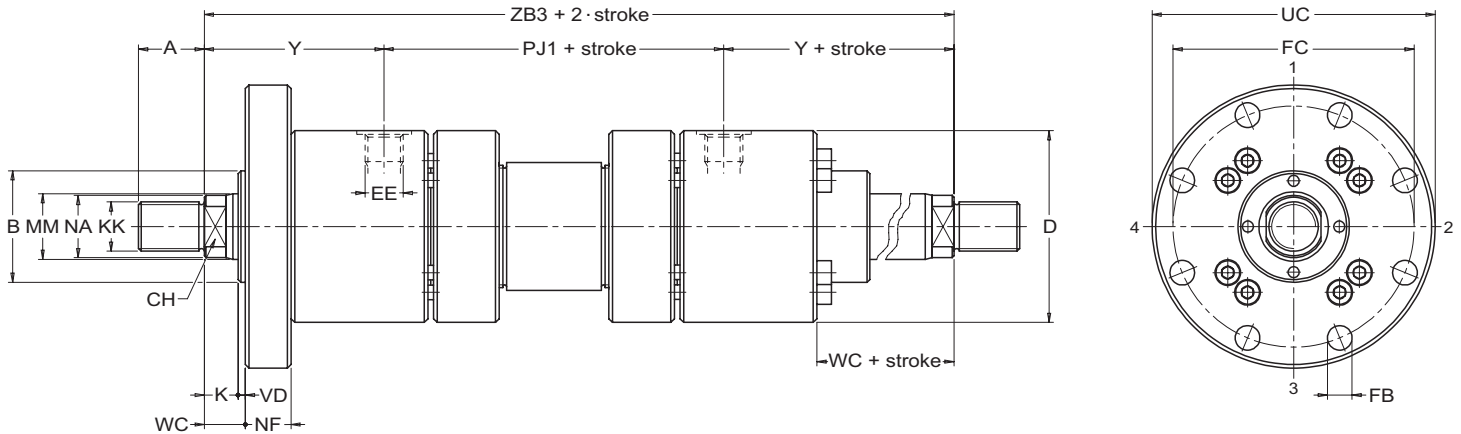

Bore Ø	MM Ø	A	B <sup>FB</sup> Ø	CH	D <sub>max</sub> Ø	EE (BSP)	KK (Metric)	NA Ø	K	VD	WC	NF	FB Ø	FC Ø	UC Ø	Y	PJ1	ZB3
50	32	36	63	28	105	1/2"	M27x2	31	18	4	22	25	13,5 N° 8 holes	132	155	98	126	322
	36			35														
63	40	45	75	34	122	3/4"	M33x2	38	21	4	25	28	13,5 N° 8 holes	150	175	112	134	358
	45			43														
80	50	56	90	43	145	3/4"	M42x2	48	24	4	28	32	17,5 N° 8 holes	180	210	120	153	393
	56			54														
100	63	63	110	53	175	1"	M48x2	60	27	5	32	36	22 N° 8 holes	212	250	134	165	433
	70			67														
125	80	85	132	65	210	1"	M64x3	77	31	5	36	40	22 N° 8 holes	250	290	153	204	510
	90			87														
140 <sup>1</sup>	90	90	145	75	255	1" 1/4	M72x3	87	31	5	36	40	26 N° 8 holes	300	340	181	208	570
	100			96														
160	100	95	160	85	270	1" 1/4	M80x3	96	35	5	40	45	26 N° 8 holes	315	360	185	225	595
	110			106														
180 <sup>1</sup>	110	105	185	95	315	1" 1/4	M90x3	106	40	5	45	50	33 N° 8 holes	365	420	205	250	660
	125			121														
200	125	112	200	-	330	1" 1/4	M100x3	121	40	5	45	56	33 N° 8 holes	385	440	220	271	711
	140			136														
250	160	125	250	-	410	1" 1/2	M125x4	155	42	8	50	63	39 N° 8 holes	475	540	260	308	828
	180			175														
320	200	160	320	-	510	2"	M160x4	195	48	8	56	80	45 N° 8 holes	600	675	310	350	970
	220			214														
400	250	200	400	-	628	2"	M200x4	242	53	10	63	100	45 N° 12 holes	720	800	310	355	975
	280			270														

<sup>1</sup> Bore non-compliant with ISO 6022 standard.

Unless otherwise specified, all dimensions are given in millimetres.

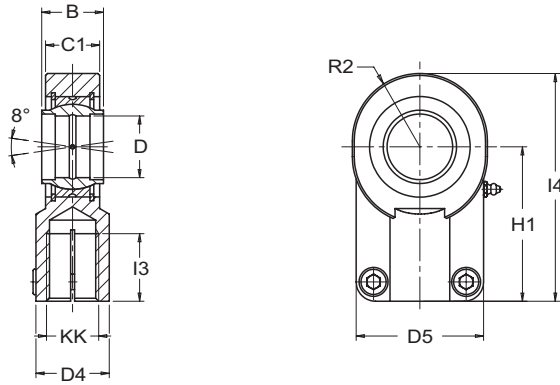

## Rod eye with spherical bearing (ISO 6982/DIN 24338)

Bore Ø	KK (Metric)	B <sup>h12</sup>	C1	D <sup>H7</sup> Ø	R2	D4	D5 <sub>max</sub>	H1	I3 <sub>min</sub>	I4	Code
50	M27x2	32	28	32	35,5	38	66	80	37	118	0205004000032
63	M33x2	40	33	40	45	47	80	97	46	146	0205004000040
80	M42x2	50	41	50	54,5	58	96	120	57	179	0205004000050
100	M48x2	63	53	63	68	70	114	140	64	211	0205004000063
125	M64x3	80	67	80	85	90	148	180	86	270	0205004000080
140 <sup>!</sup>	M72x3	90	72	90	92,5	100	160	195	91	296	0205004000090
160	M80x3	100	85	100	105,5	110	178	210	96	322	0205004000100
180 <sup>!</sup>	M90x3	110	88	110	117,5	125	190	235	106	364	0205004000110
200	M100x3	125	103	125	132,5	135	200	260	113	405	0205004000125
250	M125x4	160	130	160	163	165	250	310	126	488	0205004000160
320	M160x4	200	162	200	209	215	320	390	161	620	0205004000200

! Bore non-compliant with ISO 6022 standard.  
All dimensions are given in millimetres.

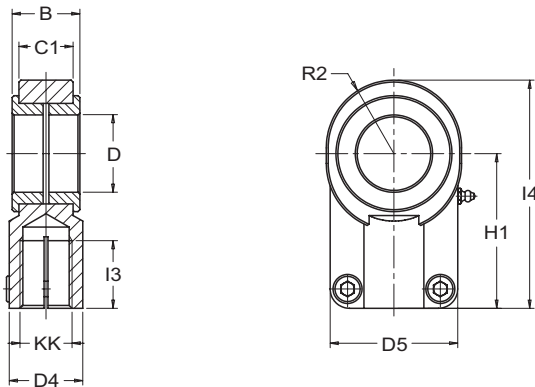
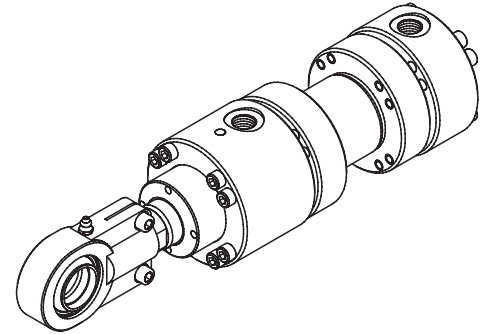

## Rod eye with plain bearing (ISO 6981/DIN 24337)

Bore Ø	KK (Metric)	B <sup>h12</sup>	C1	D <sup>H9</sup> Ø	R2	D4	D5 <sub>max</sub>	H1	I3 <sub>min</sub>	I4	Code
50	M27x2	32	28	32	35,5	38	66	80	37	118	0205026000032
63	M33x2	40	33	40	45	47	80	97	46	146	0205026000040
80	M42x2	50	41	50	54,5	58	96	120	57	179	0205026000050
100	M48x2	63	53	63	68	70	114	140	64	211	0205026000063
125	M64x3	80	67	80	85	90	148	180	86	270	0205026000080
140 <sup>!</sup>	M72x3	90	72	90	92,5	100	160	195	91	296	0205026000090
160	M80x3	100	85	100	105,5	110	178	210	96	322	0205026000100
180 <sup>!</sup>	M90x3	110	88	110	117,5	125	190	235	106	364	0205026000110
200	M100x3	125	103	125	132,5	135	200	260	113	405	0205026000125
250	M125x4	160	130	160	163	165	250	310	126	488	0205026000160
320	M160x4	200	162	200	209	215	320	390	161	620	0205026000200

! Bore non-compliant with ISO 6022 standard.  
All dimensions are given in millimetres.

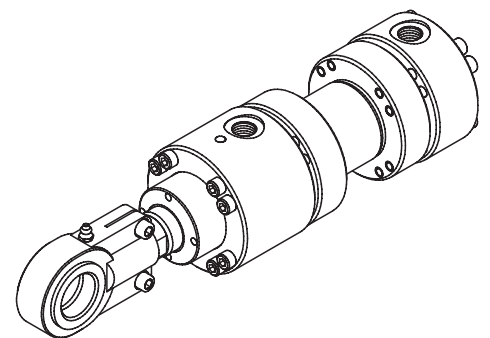



# ISO 6022 09 Series

## Fork joint hinge with pin (ISO 8133)

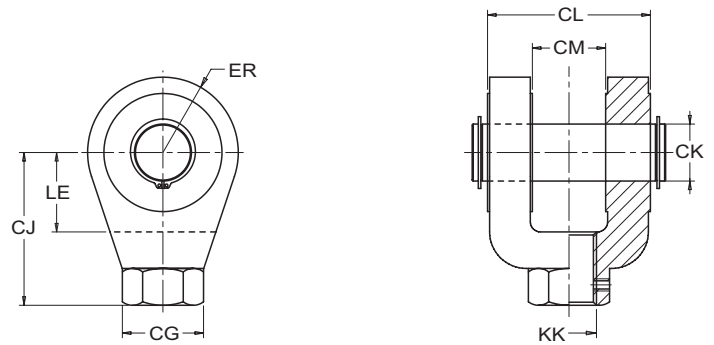

Bore Ø	KK (Metric)	CK <sup>f8</sup> Ø	CL <sub>max</sub>	CM <sup>b12</sup>	CJ <sup>js13</sup>	LE <sub>min</sub>	ER <sub>max</sub>	CG	Code
50	M27x2	28	80	40	75	39	34	40	0205007000027
63	M33x2	36	100	50	99	54	50	56	0205007000033
80	M42x2	45	120	60	113	57	53	56	0205007000042
100	M48x2	56	140	70	126	63	59	75	0205007000048
125	M64x3	70	160	80	168	83	78	95	0205007000064
140 <sup>!</sup>	M72x3	70	160	80	168	83	78	95	0205007000072
160	M80x3	70	160	80	168	83	78	95	0205007000080
180 <sup>!</sup>	M100x3	100	230	100	250	90	95	160	0205007000100

! Bore non-compliant with ISO 6022 standard.  
All dimensions are given in millimetres.

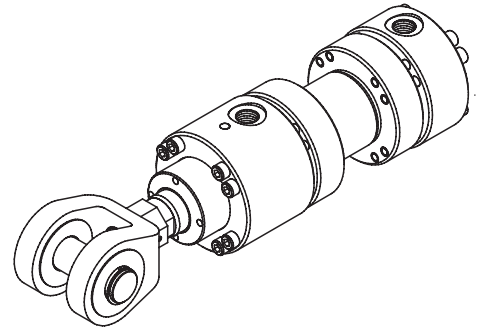

## Weights of the 09 series

Note the bore, diameter of rod, mounting type and stroke, the total weight of the cylinder is calculated by adding the weight in Kg according to mounting type at blank stroke to the weight for each 10 mm of stroke, multiplied by the stroke in cm.

Bore Ø mm	Rod Ø mm	Weight in kg according to the mounting type at blank stroke				Weight for every 10 mm of stroke
		03	06 - 07	08	13 - 14	
50	32	16	16	17	14	0,2
	36					
63	40	25	27	27	28	0,3
	45					
80	50	35	38	39	39	0,5
	56					
100	63	56	62	63	61	0,6
	70					
125	80	95	107	110	103	0,9
	90					
140 <sup>!</sup>	90	158	173	175	164	1,1
	100					
160	100	188	210	208	198	1,6
	110					
180 <sup>!</sup>	110	274	296	298	289	2,0
	125					
200	125	335	365	364	356	2,2
	140					
250	160	634	698	685	666	3,2
	180					
320	200	1136	1314	1259	1200	5,1
	220					
400	250	2131	2259	2249	2180	7
	280					
		2202	2330	2320	2250	7,5

! Bore non-compliant with ISO 6022 standard.

## Inductive proximity sensors

The end-of-stroke sensors use technology of the Hall effect inductive type for reading and can be mounted both on the head and the cap as long as the mounting and other types of connection present on the same side allow for this in accordance with information given in Table 13 on page 36. The sensors can be applied to all mounting types of ISO 6022 cylinders and to both heads for every available bore.

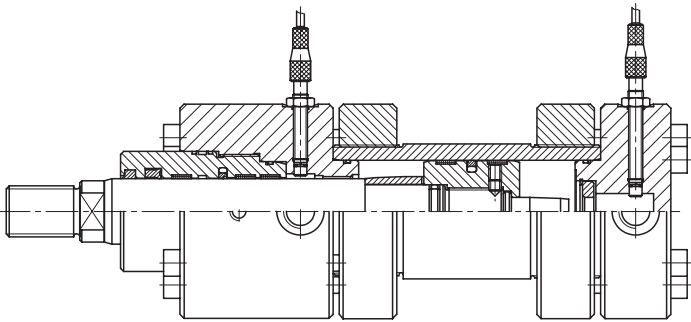

The working principle of the inductive proximity sensor is based on the interaction of the metal conductors with their own alternative electromagnetic field.

When the piston arrives at the end of stroke, the sensor detects the presence of the conductor material of which the cushion is made and gives the signal for movement to be performed.

The cylinders must therefore necessarily be provided with cushion in proximity of the sensor.

The end-of-stroke sensors installed on CMB cylinders are tested to work correctly in temperatures ranging from -20°C to +70°C, are not influenced by vibrations and can be supplied on request with steel guards covering the outer part of the sensor.

Cylinders equipped with inductive sensors can also be fitted with fluoroelastomer seals (identified by the letter **V**) exclusively for use with aggressive hydraulic fluids and not for use at high temperatures.

## Features of inductive sensors

CMB ISO 6022 09 series cylinders with end of stroke sensors are supplied with PNP type inductive sensors (the charge is connected to the supply positive) and with outlet of the normally open type (N.O.).

These devices cannot be used to directly pilot a power load but only to provide the switching signal (pure contact).

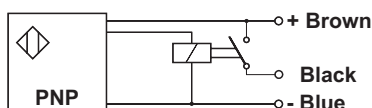

Inductive sensor technical specifications:

- Sensor screw thread: M12x1
- Coupling torque: 15 Nm
- Reading signal space: 1÷1,2 mm
- Working voltage: 10÷30 V CC
- Current capacity: 200 mA
- Working frequency: 1000 Hz
- Circuit protection: si
- Max. pressure: 500 bar
- Repeatability accuracy: < 5%

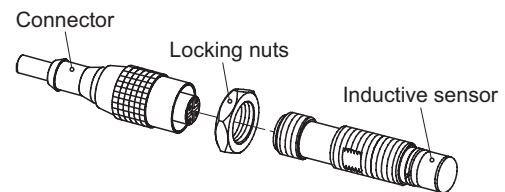

CMB supplies straight connectors without LED (code **02990030000003**) as standard together with inductive sensors. These present the following technical features:

- connector: M12 pre-cabled - IP68
- cable type: with 3 x 0,34 mm<sup>2</sup> leads
- cable length: 3 mt.
- cable material: polyurethane (oil resistant)

90° angled connectors with LED are available as an optional, enabling the dismantling space and outer overall dimensions of the cylinder to be reduced to which however the steel guards cannot be applied; when placing an order, specify the quantity followed by the following code:

- **02990030000001** - 90° angled connector

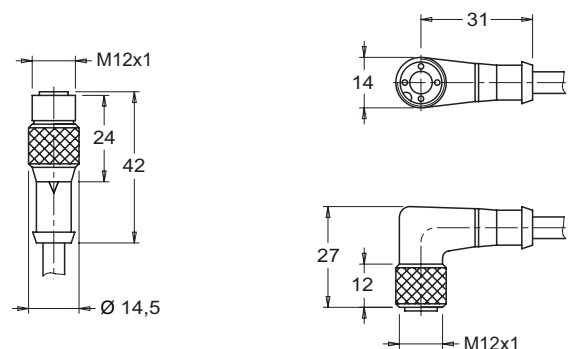

Fig. 1 - Straight and 90° angled connector space requirements

## Introduction to T9 series cylinders

T9 series ISO 6022 hydraulic cylinders are hydraulic actuators designed to take linear position transducers and return the rod to its starting position.

These hydraulic devices combined with a magnetostrictive transducer and suitable electronic conditioning enable a reliable, accurate and compact control system to be achieved which allows for great flexibility of use in all types of applications.

T9 series cylinders are fitted as standard with air bleeds on the head and cap to enable air present in the rod cavity in which the transducer wave guide is housed to be released. This range of cylinders is equipped with a special piston which allows the cylinder to be fitted with cushioning on the side of the cap even when a linear transducer is present. Cylinders designed to take linear position transducer are available and can have cushioning on request on all bores, with a limitation for 50 and 63 bores that can't have rear cushioning.

On request, special protective covers can be produced to cover the exposed part of the transducer.

## Mounting type

T9 series cylinders are available for all the mounting types except for the pivot mounting versions.

For special applications however, CMB can also supply these mounting types as a custom-built product. For more detailed information, please contact our Technical Department.

## Magnetostrictive transducer

A magnetostrictive transducer is a device made up of a special alloy pipe through which a connector solidly fixed to the cap of the cylinder is threaded and along which a permanent magnet inside the piston slides.

The measuring process begins with a short electrical impulse emitted by the lead head which is transmitted at a constant speed along the wave guide until it reaches the position reader (permanent magnet), which causes it to invert due its magnetostrictive effect.

The time for the wave to carry out the return trip from its original point to the signal emitter is directly proportional to the distance present between the position reader (therefore the position of the piston) and the emitter.

The absence of sliding contact elements between the moving parts of the transducer guarantees a long working life reducing all kinds of maintenance to a minimum. The transducer can easily be removed from its housing without having to dismantle the cylinder.

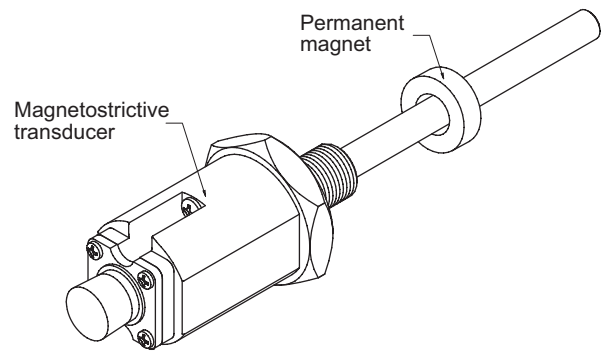

Fig. 2 - Magnetostrictive transducer complete with permanent magnet

## Types of output signals available

CMB offers a wide range of magnetostrictive transducers equipped with conversion electronics that provide three different types of output signal:

- **Linear-analog**
- **Serial-Synchronous (SSI)**
- **Can-Bus**
- **Profibus-DP**

The **Linear-analog** output provides an analog signal which can be leak voltage or current; leak current outputs are preferable to voltage outputs when electrical disturbances are present which may distort the signal.

With the **Sincrono-Seriale (SSI)** output, the position of the permanent magnet along the stretch being measured is transmitted directly to the controller or electronic axis adjustment circuits using SSI input by means of a train of synchronised clock impulses.

**Can-Bus** and **Profibus-DP** are types of digital data transmission produced using controllers fitted with a module at the head connected to the various devices present on the machine (actuators with linear transducers, drive systems, sensors etc.) by means of a quite normal two-way adaptor. These transducers are different because they have two different types of output signal: Can-Bus according to ISO 11898 specifications and Profibus-DP according to ISO 74498 specifications.

In order to increase the efficiency of the actuator, software functions can be implemented in the transducers with Can-Bus and Profibus-DP output, which enable not only the position readings and piston speeds to be determined but also movement profile and speed to be measured.

## CE mark

All magnetostrictive transducers and sensors (both magnetic and inductive) supplied by CMB respect the electromagnetic compatibility requirements of standard **EN 60 947-5-2** appendix ZA.

The CE mark applied to the connectors and electronic devices supplied by us indicates that the products marketed comply with the requirements of **CEE 89/336/CEE** directive (directive **EMV**) and relevant legislation.

## Rear dimensions of transducer with flying connector

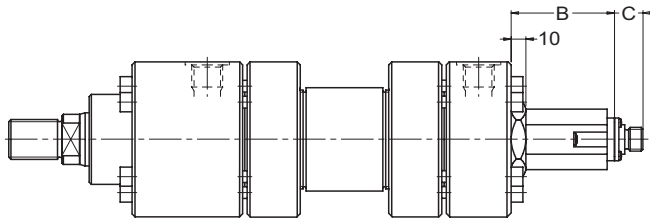

## Rear dimensions of transducer integral cable

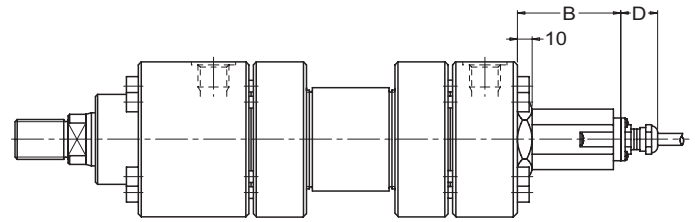

## Types and dimensions of connectors

CMB hydraulic cylinders equipped with magnetostrictive transducers can be supplied with four models of connectors to be ordered separately (connection cable not supplied). Models with 6 pins are used exclusively for Analog-linear transducers and Can-Bus while those with 7 pins are used for the SSI:

- Code **02990060000001** - 6 pins DIN metal connector with direct female coupling
- Code **02990060000002** - 6 pins DIN metal connector with 90° square, adjustable direction female coupling
- Code **02990060000003** - 7 pins DIN metal connector with direct female coupling
- Code **02990060000004** - 7 pins DIN metal connector with 90° square, adjustable direction female coupling

Chart showing dimensions of magnetostrictive transducers:

B Linear analog	B SSI, Can-Bus e Profibus-DP	C <sub>max</sub>	D <sub>max</sub>
65	83,5*	13	20

\* To add 10 millimeter with electrical stroke greater of 3500 millimeter

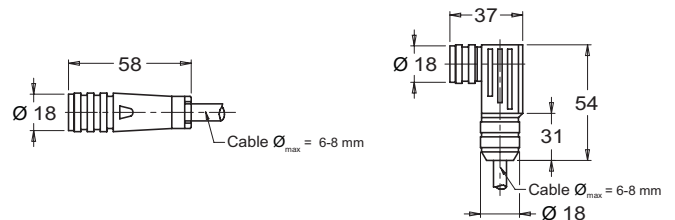

6 or 7 pins DIN metal connector with direct

7 pins DIN metal connector with 90° square, adjustable direction female coupling

## Technical features of Linear-analog transducer

### Features

<b>Measured variable</b>	Displacement
<b>Measuring range</b>	50 - 1650 mm
<b>Output signal voltage</b>	0 ... + 10 V e + 10 V ... 0 V Load resistance $R_L \geq 5$ kOhm
<b>Output signal current</b>	4 ... 20 mA e 20 ... 4 mA 0 ... 20 mA e 20 ... 0 mA Load resistance $R_L \geq 100$ Ohm
<b>Resolution</b>	Infinite
<b>Linearity tolerance</b>	$\leq \pm 0,05$ % F.S. (minimum $\pm 50$ $\mu$ m)
<b>Repeatability</b>	$\leq \pm 0,001$ % F.S. (minimum $\pm 2,5$ $\mu$ m)
<b>Hysteresis</b>	$\leq 20$ $\mu$ m
<b>Connection type</b>	Integrated connector or cable
<b>Input voltage</b>	24 V d.c. ( $\pm 25$ %)
<b>Current drain</b>	80 mA typical
<b>Ripple</b>	$\leq 1$ % peak to peak
<b>Temperature coefficient</b>	70 ppm/° C typical (valid for output signal voltage only) 90 ppm/° C typical (valid for output current signal only)
<b>Operating temperature</b>	- 40° C ... + 65° C
<b>Mounting position</b>	Any orientation
<b>Magnet speed</b>	Any
<b>Sensor head</b>	Aluminium diecasting housing
<b>Sensor rod with flange</b>	Stainless steel
<b>Pressure rating</b>	350 bar (530 Bar peak pressure)
<b>Protection degree</b>	IP 67 (Rod, flange) IP 65 (Sensor head)
<b>Threaded flange</b>	M 18 x 1,5
<b>Magnet type</b>	GF plastic with permanent magnets

## Ordering code for Linear-analog transducer

Features	Description	Code
<b>Transducer type</b>	Linear-analog with rod housing	LH
<b>Flange type</b>	Threaded flange M 18 x 1,5 (standard)	M
<b>Connection type</b>	Screw connector with 6 pins	D0
	PVC cable 1,5 mt.	R0
	10 mt. PVC cable, with or without connector (specify cable length and connector)	RX
<b>Metering unit</b>	Millimeters	M
<b>Measuring range</b>	Standard from 50 to 1650 mm	-
<b>Output</b>	0 ... 10 V e 10 ... 0 V	V0
	4 ... 20 mA	A0
	20 ... 4 mA	A1
	0 ... 20 mA	A2
	20 ... 0 mA	A3
	Start/Stop (ask the builder)	R0

Ordering code for Linear-analog transducer

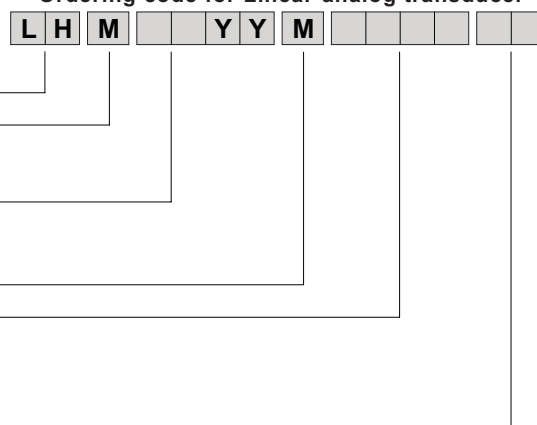

## Technical features of SSI, Can-Bus and Profibus-DP transducers

Features	
<b>Measured variable (SSI transducer)</b>	Position
<b>Measured variable (Can-Bus e Profibus-DP transducer)</b>	Displacement and position
<b>Measuring range</b>	25 - 6000 mm
<b>Output signal (SSI transducer)</b>	SSI (Synchronous Serial Interface) - RS 422/485 Standard
<b>Output signal (Can-Bus transducer)</b>	Can-Bus system according ISO 11898
<b>Output signal (Profibus-DP transducer)</b>	Profibus-DP system according ISO 74498
<b>Data format (SSI transducer)</b>	Binary or Gray encodes
<b>Data length (SSI transducer)</b>	25 o 24 bit (on request)
<b>Data format (Can-Bus transducer)</b>	CAN Base 2.0 A
<b>Data format (Profibus-DP transducer)</b>	Profibus-DP (EN 50 170)
<b>Resolution (SSI and Can-Bus transducer)</b>	2 µm maximum
<b>Resolution (trasduttore Profibus-DP)</b>	5 µm maximum
<b>Baud Rate (trasduttore Can-Bus)</b>	Selectable: 1000, 500, 250 e 125 Kbit/sec.
<b>Linearity tolerance (uncorrected)</b>	< ± 0,01 % F.S. (minimum ± 40 µm) independent of external temperature influence
<b>Repeatability</b>	< ± 0,001 % F.S. (minimum ± 2,5 µm)
<b>Hysteresis</b>	< 4 µm
<b>Connection type</b>	Integrated connector or cable
<b>Input voltage</b>	24 V d.c. (+ 20 % / - 15%)
<b>Current drain (SSI transducer)</b>	70 mA typical
<b>Current drain (Can-Bus and Profibus-DP transducer)</b>	90 mA typical
<b>Ripple</b>	< 1 % peak to peak
<b>Temperature coefficient</b>	< 15 ppm/° C
<b>Electric strength</b>	500 V (D.C. ground to machine ground)
<b>Operating temperature</b>	- 40° C ... + 75° C
<b>EMC-Test</b>	DIN IEC 801-4 / type 4 / CE qualified
<b>Shock rating</b>	100 g (single hit) / IEC-Standard 68-2-27
<b>Vibration rating</b>	5 g / 10 -150 Hz / IEC-Standard 68-2-6
<b>Mounting position</b>	Any orientation
<b>Magnet speed</b>	Any
<b>Electronic head</b>	Aluminium diecasting housing
<b>Sensor rod with flange</b>	Stainless steel
<b>Pressure rating</b>	350 bar (530 Bar peak pressure)
<b>Protection degree</b>	IP 67 (if mating connector is correctly fitted)
<b>Threaded flange</b>	M 18 x 1,5
<b>Magnet type</b>	GF plastic with permanent magnets



## Ordering code for Profibus-DP transducer

Features	Description	Code
Transducer type	Profibus-DP with rod housing	RH
Flange type	Threaded flange M 18 x 1,5 (standard)	M
Measuring range	Standard from 25 to 6000 mm	-
Connection type	Screw connector with 4 pins	D52
	Screw connector with 6 pins	D63
Input voltage	+ 24 V d.c.	1
Output	Profibus-DP (standard)	P102

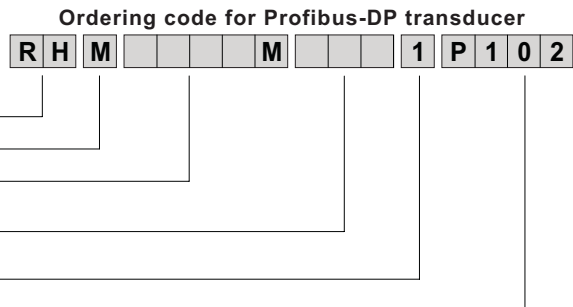

## Electrical connections

T9 series CMB hydraulic cylinders come complete with all the manufacturer's technical documentation regarding the identification and wiring of transducer connectors.

For all further technical information regarding the installation and/or electrical connection of transducers, contact our Technical Department.

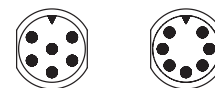
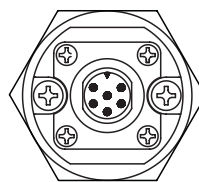

External view 6 or 7 pins connection

## Storage and maintenance

To guarantee the cylinders a long life, CMB recommends you follow the following maintenance rules extremely carefully:

- Store the cylinders in a closed, dry environment in a vertical position with the rod pointing upwards to reduce the chance of corrosion taking place inside due to condensation.
- The rod, screw threads, centres and all the accessories applied to the rod and cap must be protected not only from aggressive agents but also from knocks which could compromise their proper working.
- The protective caps fitted on the connections must not be removed until the time of installation in order to prevent dirt and/or foreign bodies from entering the cylinder.
- After installation, periodically check the cylinder to make sure there are no traces of oil due to the seals wearing out or any damage to mechanical parts. If there are, provide for their replacement as soon as possible.
- When in function, make sure the rod does not rotate around its own axis. In the event that rotation becomes necessary, remove supply pressure and proceed with the operation.
- The seals kits supplied by CMB as well as spare parts must be stocked in a dry environment and direct contact with sources of heat and direct exposure to sunlight must be avoided.
- If it becomes necessary to re-mount the cylinders, tighten the screws diagonally, applying a gradual coupling torque until the maximum value given in the chart is reached (values refer to dry threads):

Bore (mm)	50	63	80	100	125	140 <sup>!</sup>	160	180 <sup>!</sup>	200	250	320	400
Screw in classe 12.9	M8	M10	M12	M16	M16	M24	M24	M24	M24	M27	M30	M36
Coupling torque (Nm)	39	77	135	330	330	1100	1100	1100	1100	1650	2250	3850

<sup>!</sup> Bore non-compliant with ISO 6022 standard.

## Replacing bush seals

The presence of leaking fluid in proximity of the bush means that the seals need replacing.

To replace these, dismantle the mechanical parts and worn out seals making sure you follow the recommendations given below very carefully, remembering that in many cases poor functioning is due exclusively to the seals not being fitted properly:

- Remove the supply pressure and drain off the remaining hydraulic fluid present in the cylinder chamber.
- Unscrew the retention grub screw and dismantle the flange bush, sliding it along the rod to extract it.
- After dismantling the worn-out seals, wash the bush carefully so that it is perfectly clean, making sure it is free from all metal particles and that there is no scoring or surface flaws of any kind on it; if these are present, replace it by requesting the spare part from CMB.
- Lubricate the new seals and bush using the same hydraulic fluid used in the installation or another type of compatible fluid.
- Carefully check the direction the seals lie in with respect to the direction the hydraulic thrust fluid works in as highlighted in the figures below.

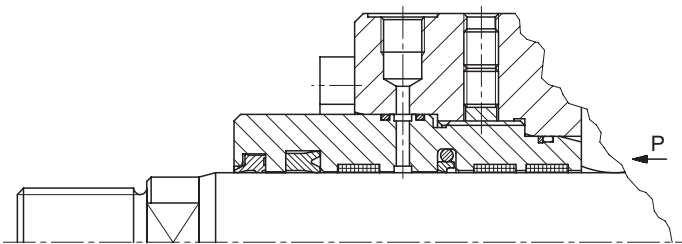

Standard bush

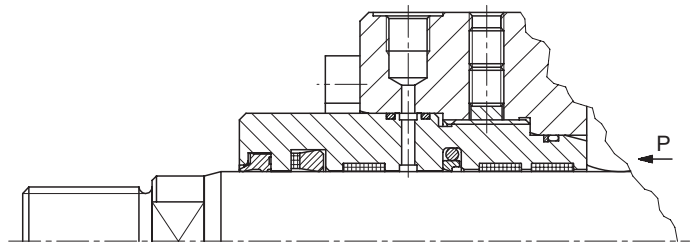

Bush for water and glycol mixtures,  
high temperatures and/or aggressive fluids

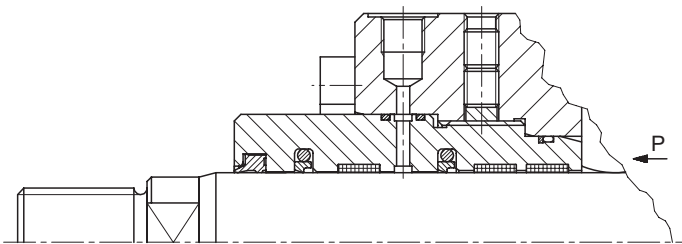

Low friction bush

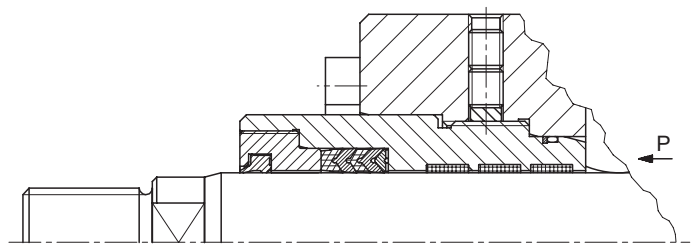

Bush for heavy applications

- Install the seals in the bush, fitting them evenly without the use of metal tools with sharp edges making sure the seals do not remain deformed for long periods of time.
- When mounting the bush, be careful not to damage the seals by these coming into contact with the rod thread screw and rotate the bush to facilitate fitting it onto the rod.
- Slide the bush along the rod and screw it down into the flange locking it into position using the retention grub screw.



# ISO 6022 09 Series

## Exploded view showing 09 series cylinders mechanical spare parts

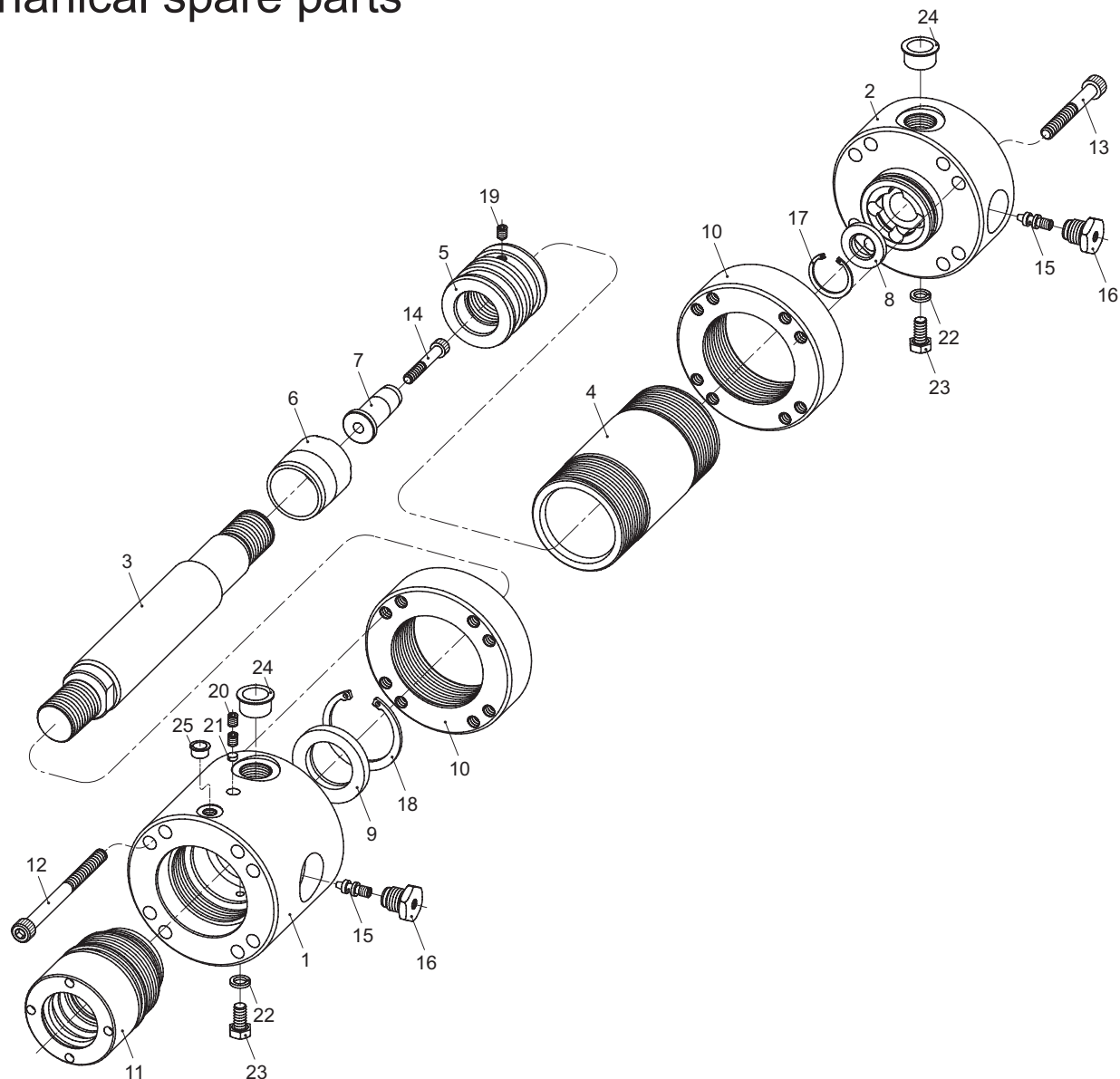

Tab.1 - Mechanical spare parts for 09 series cylinders

Pos.	Description	Notes
1	Head	-
2	Cap	-
3	Rod	-
4	Cylinder tube	-
5	Piston	-
6	Front cushioning sleeve	Only if fitted with cushion
7	Rear cushioning sleeve	Only if fitted with cushion
8	Rear cushioning bush	Only if fitted with cushion
9	Front cushioning bush	Bores 160, 180, 200, 250, 320, 400 only if fitted with cushion
10	Locking flange	-
11	Rod bushing	-
12	Screw fixing head	-
13	Screw fixing cap	-

Pos.	Description	Notes
14	Screw fixing rear cushioning	Bores 160, 180, 200, 250, 320, 400 only if fitted with cushion
15	Adjustment cushioning screw	Only if fitted with cushion
16	Cushion needle valve cartridge	Only if fitted with cushion
17	Rear cushioning elastic ring	Only if fitted with cushion
18	Front cushioning elastic ring	Bores 160, 180, 200, 250, 320, 400 only if fitted with cushion
19	Grub screw locking piston	-
20	Grub screw locking rod bushing	-
21	Bushing thread-braking pellet	-
22	Copper washer	Only if fitted with air bleeds
23	Air bleeds screw	Only if fitted with air bleeds
24	Screw thread protection cap	-
25	Screw thread protection cap	Only if fitted with drainage

## Spare seals kit for standard 09 series cylinders and for 09 series with inductive sensors

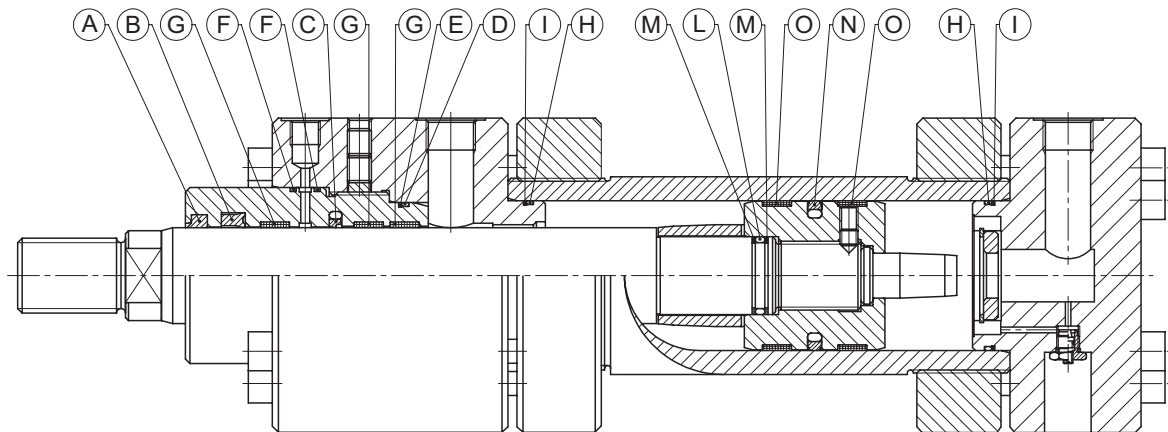

Tab.2 - Spare seals kit for standard 09 series cylinders and for 09 series with inductive sensors

Pos.	Description	Notes
A	Scraper	-
B	Rod lipseal	-
C	Rod low friction seal	-
D	Rod bushing O-Ring	-
E	Rod bushing O-Ring back up washer	-
F	Drainage rod bushing O-Ring	Only if fitted with drainage
G	Rod guide ring	-
H	Tube cylinder O-Ring	-
I	Tube cylinder O-Ring back up washer	-
L	Piston O-Ring	-
M	Piston O-Ring back up washer	-
N	Piston seal	-
O	Piston guide ring	-
P	Cushioning screw O-Ring	Only if fitted with cushion
Q	Cushioning needle valve cartridge O-Ring	Only if fitted with cushion
R	Cushioning needle valve cartridge O-Ring back up washer	Only if fitted with cushion

Detail showing cushioning adjustment

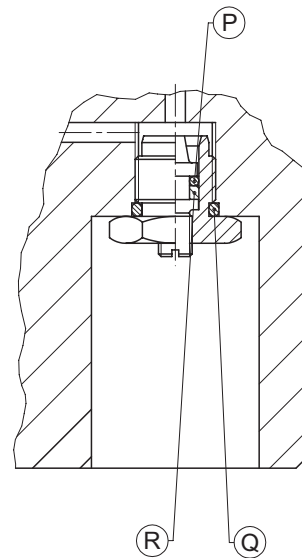

The following tables describe the procedure for ordering complete spare seals kit:

Tab.3 - Complete seals kit for standard 09 series cylinders and for 09 series with inductive sensors

Features	Description	Code
<b>Kit series</b>	Complete seals kit for 09 series cylinders compliant with ISO 6022 standards and for 09 series with inductive sensors	K9
<b>Bore</b>	Specify bore in mm	-
<b>Rod</b>	Specify rod diameter by letter (see cylinder ordering code at page 2)	A
<b>Seals type</b>	Normal (Nitrile rubber, Polyurethane, PTFE charged bronze)	0
	High temperature and/or aggressive fluid (Fluoroelastomer, PTFE charged bronze)	1*
	Water and glycol mixtures (Nitrile rubber, PTFE charged bronze)	7
	Low friction (Nitrile rubber, PTFE charged bronze)	9
	Heavy application (Nitrile rubber, charged nitrile rubber cotton fabric)	20

Seals ordering code

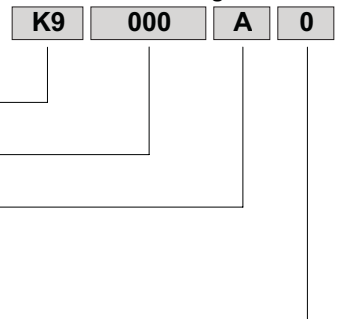

\* Maximum working temperature for 09 series cylinders equipped with inductive sensors: 70 °C

# ISO 6022 09 Series

Exploded view showing mechanical spare parts for 09 series double rod cylinders

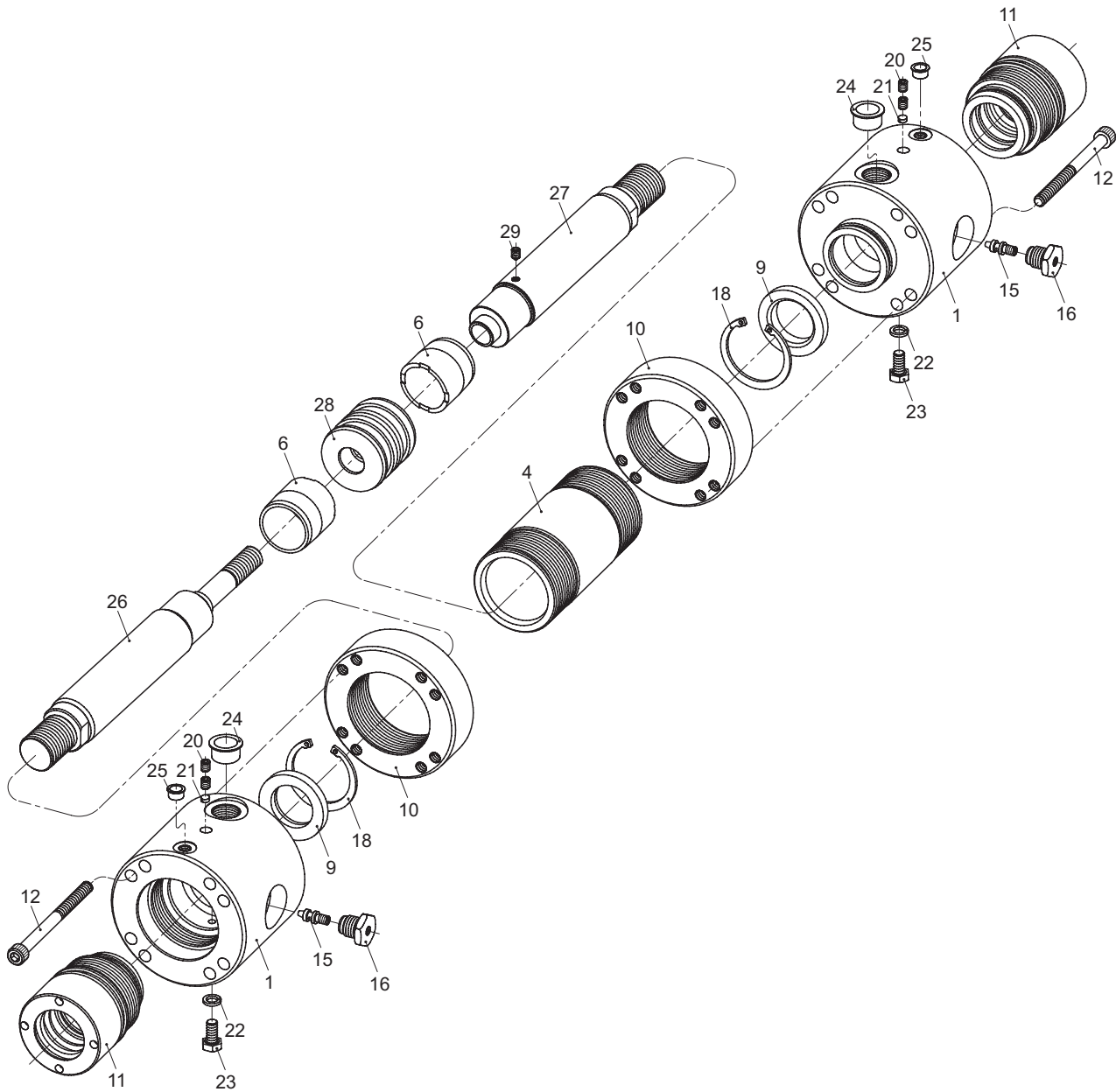

Tab.4 - Mechanical spare parts for 09 series double rod cylinders

Pos.	Description	Notes
1	Head	-
4	Cylinder tube	-
6	Front cushioning sleeve	Only if fitted with cushion
9	Front cushioning bush	Bores 160, 180, 200, 250, 320, 400 only if fitted with cushion
10	Locking flange	-
11	Rod bushing	-
12	Screw fixing head	-
15	Adjustment cushioning screw	Only if fitted with cushion
16	Cushion needle valve cartridge	Only if fitted with cushion
18	Front cushioning elastic ring	Bores 160, 180, 200, 250, 320, 400 only if fitted with cushion

Pos.	Description	Notes
20	Grub screw locking rod bushing	-
21	Bushing thread-braking pellet	-
22	Copper washer	Only if fitted with air bleeds
23	Air bleeds screw	Only if fitted with air bleeds
24	Screw thread protection cap	-
25	Screw thread protection cap	Only if fitted with drainage
26	Front rod	-
27	Rear rod	-
28	Piston	-
29	Grub screw locking rod	-

## Spare seals kit for standard 09 series double rod cylinders and for 09 series double rod with inductive sensors

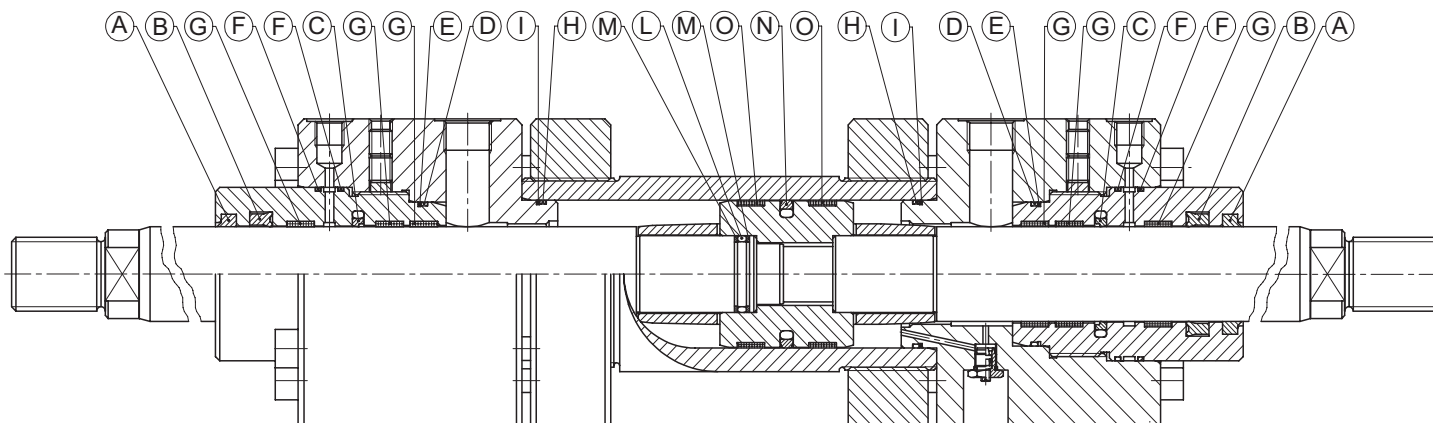

Tab.5 - Spare seals kit for standard 09 series double rod cylinders and for 09 series double rod with inductive sensors

Pos.	Description	Notes
A	Scraper	-
B	Rod lipseal	-
C	Rod low friction seal	-
D	Rod bushing O-Ring	-
E	Rod bushing O-Ring back up washer	-
F	Drainage rod bushing O-Ring	Only if fitted with drainage
G	Rod guide ring	-
H	Tube cylinder O-Ring	-
I	Tube cylinder O-Ring back up washer	-
L	Piston O-Ring	-
M	Piston O-Ring back up washer	-
N	Piston seal	-
O	Piston guide ring	-
P	Cushioning screw O-Ring	Only if fitted with cushion
Q	Cushioning needle valve cartridge O-Ring	Only if fitted with cushion
R	Cushioning needle valve cartridge O-Ring back up washer	Only if fitted with cushion

Detail showing cushioning adjustment

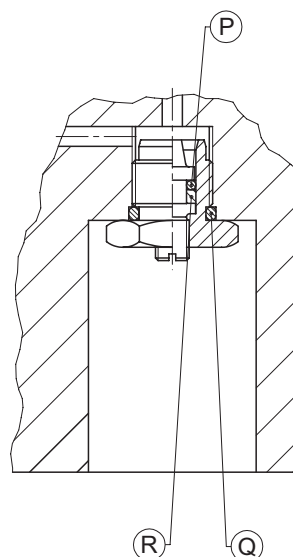

The following tables describe the procedure for ordering complete spare seals kit:

Tab.6 - Complete seals kit for standard 09 series double rod cylinders and for 09 series double rod with inductive sensors

Features	Description	Code
<b>Kit series</b>	Complete seals kit for 09 series double rod cylinders compliant with ISO 6022 standards and for 09 series double rod with inductive sensors	K9
<b>Bore</b>	Specify bore in mm	-
<b>Rod</b>	Specify rod diameter by letter (see cylinder ordering code at page 2)	A
<b>Seals type</b>	Normal (Nitrile rubber, Polyurethane, PTFE charged bronze)	2
	High temperature and/or aggressive fluid (Fluoroelastomer, PTFE charged bronze)	3*
	Water and glycol mixtures (Nitrile rubber, PTFE charged bronze)	8
	Low friction (Nitrile rubber, PTFE charged bronze)	10
	Heavy application (Nitrile rubber, charged nitrile rubber cotton fabric)	21

Seals ordering code

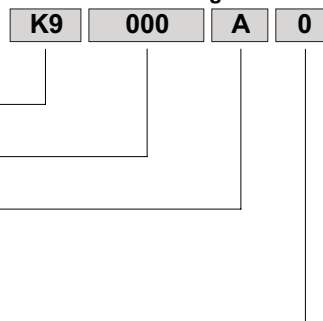

\* Maximum working temperature for 09 series double rod cylinders equipped with inductive sensors: 70 °C

# ISO 6022 09 Series

Exploded view showing mechanical spare parts for 09 series cylinders with inductive sensors

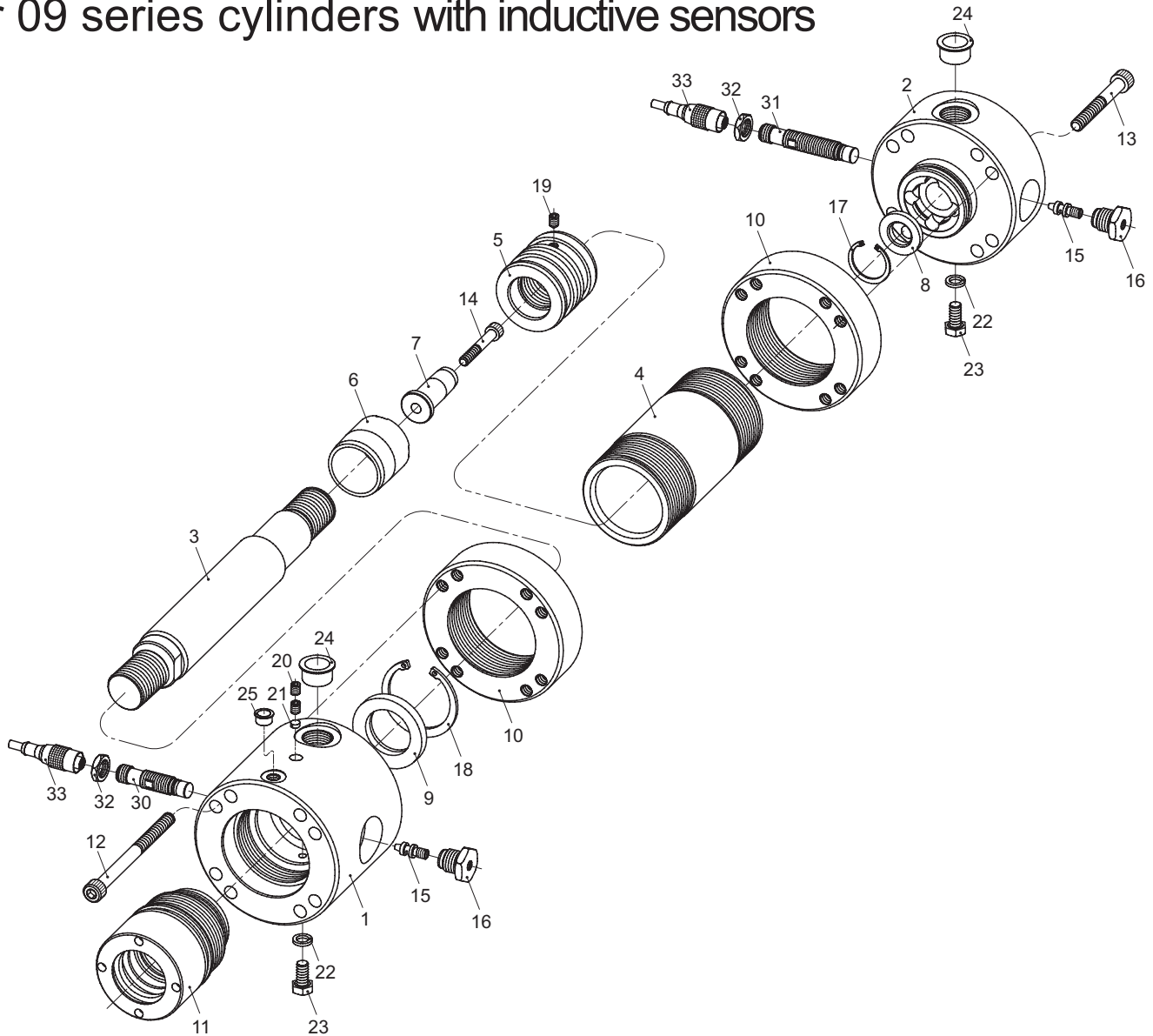

Tab.7 - Mechanical spare parts for 09 series cylinders with inductive sensors

Pos.	Description	Notes
1	Head	-
2	Cap	-
3	Rod	-
4	Cylinder tube	-
5	Piston	-
6	Front cushioning sleeve	-
7	Rear cushioning sleeve	-
8	Rear cushioning bush	-
9	Front cushioning bush	Bores 160, 180, 200, 250, 320, 400 only if fitted with cushion
10	Locking flange	-
11	Rod bushing	-
12	Screw fixing head	-
13	Screw fixing cap	-
14	Screw fixing rear cushioning	Bores 160, 180, 200, 250, 320, 400 only if fitted with cushion
15	Adjustment cushioning screw	-

Pos.	Description	Notes
16	Cushion needle valve cartridge	-
17	Rear cushioning elastic ring	-
18	Front cushioning elastic ring	Bores 160, 180, 200, 250, 320, 400 only if fitted with cushion
19	Grub screw locking piston	-
20	Grub screw locking rod bushing	-
21	Bushing thread-braking pellet	-
22	Copper washer	Only if fitted with air bleeds
23	Air bleeds screw	Only if fitted with air bleeds
24	Screw thread protection cap	-
25	Screw thread protection cap	Only if fitted with drainage
30	Head inductive sensor	-
31	Cap inductive sensor	-
32	Nut locking sensor into position	-
33	Connector	-

## Exploded view showing T9 series cylinders mechanical spare parts

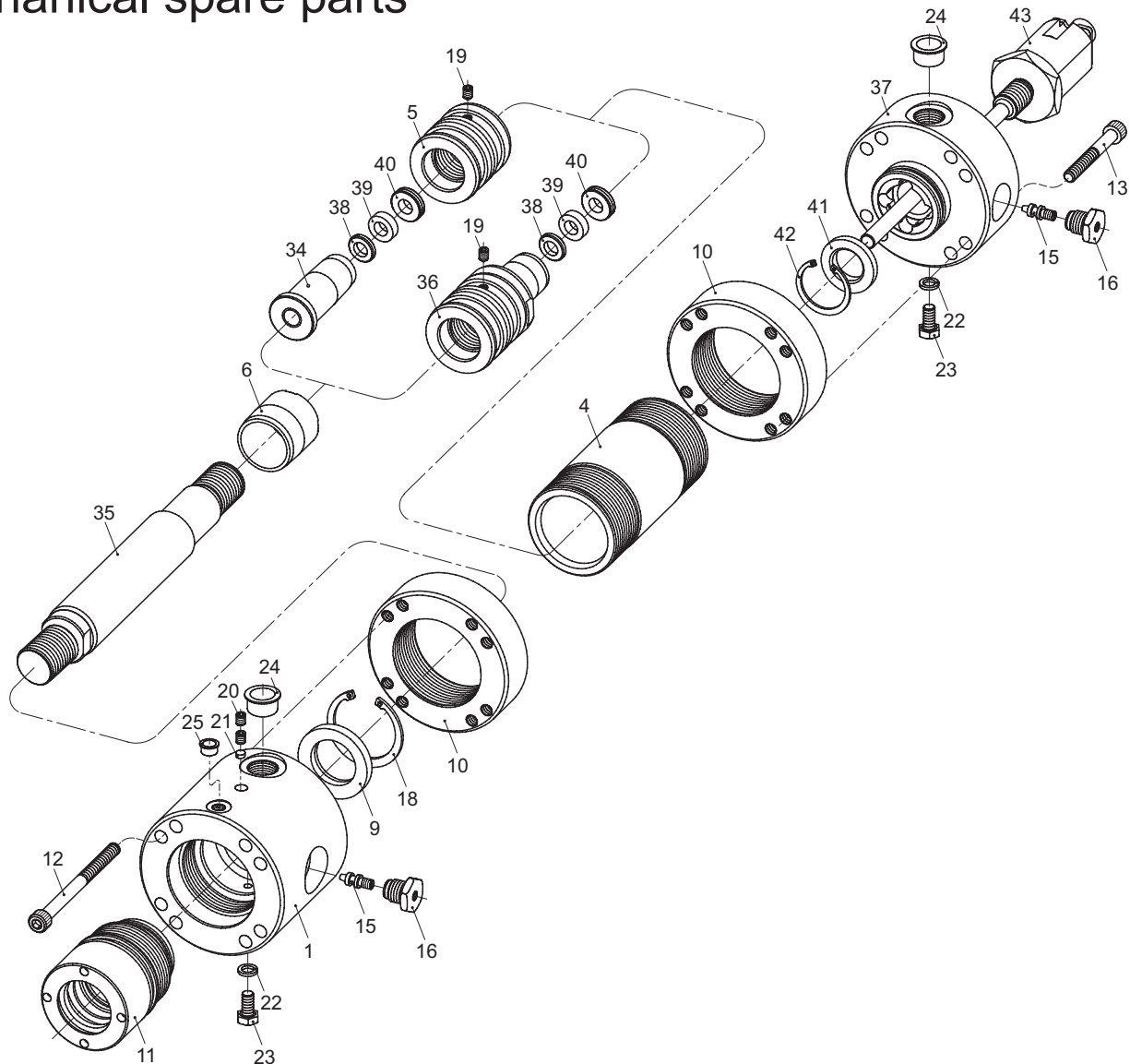

Tab.8 - Mechanical spare parts for T9 series cylinders

Pos.	Description	Notes
1	Head	-
4	Cylinder tube	-
5	Piston	Bores 160, 180, 200, 250, 320, 400 only if fitted with cushion
6	Front cushioning sleeve	Only if fitted with cushion
9	Front cushioning bush	Bores 160, 180, 200, 250, 320, 400 only if fitted with cushion
10	Locking flange	-
11	Rod bushing	-
12	Screw fixing head	-
13	Screw fixing cap	-
15	Adjustment cushioning screw	Only if fitted with cushion
16	Cushion needle valve cartridge	Only if fitted with cushion
18	Front cushioning elastic ring	Bores 160, 180, 200, 250, 320, 400 only if fitted with cushion
19	Grub screw locking piston	-
20	Grub screw locking rod bushing	-
21	Bushing thread-braking pellet	-

Pos.	Description	Notes
22	Copper washer	-
23	Air bleeds screw	-
24	Screw thread protection cap	-
25	Screw thread protection cap	Only if fitted with drainage
34	Cushioning sleeve with magnet holder for linear transducer	Bores 160, 180, 200, 250, 320, 400 only if fitted with cushion
35	Rod for linear transducer	-
36	Piston for linear transducer	Bores 50, 63, 80, 100 and 125
37	Cap for linear transducer	-
38	Amagnetic front spacer	-
39	Toroidal positioning magnet	-
40	Ring locking magnet	-
41	Rear cushioning bush	Only if fitted with cushion
42	Rear cushioning elastic ring	Only if fitted with cushion
43	Linear position transducer	Optional (supplied only on request)

# ISO 6022 09 Series

## Spare seals kit for T9 series cylinders

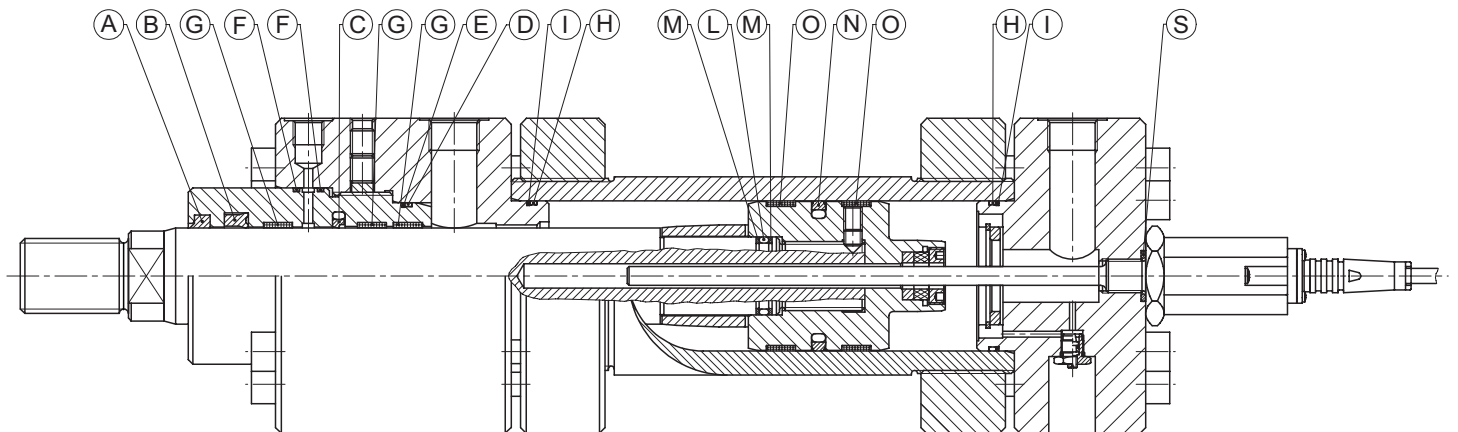

Tab.9 - Spare seals kit for T9 series cylinders

Pos.	Description	Notes
A	Scraper	-
B	Rod lipseal	-
C	Rod low friction seal	-
D	Rod bushing O-Ring	-
E	Rod bushing O-Ring back up washer	-
F	Drainage rod bushing O-Ring	Only if fitted with drainage
G	Rod guide ring	-
H	Tube cylinder O-Ring	-
I	Tube cylinder O-Ring back up washer	-
L	Piston O-Ring	-
M	Piston O-Ring back up washer	-
N	Piston seal	-
O	Piston guide ring	-
P	Cushioning screw O-Ring	Only if fitted with cushion
Q	Cushioning needle valve cartridge O-Ring	Only if fitted with cushion
R	Cushioning needle valve cartridge O-Ring back up washer	Only if fitted with cushion
S	Position transducer O-Ring	Only if fitted with cushion

Detail showing cushioning adjustment

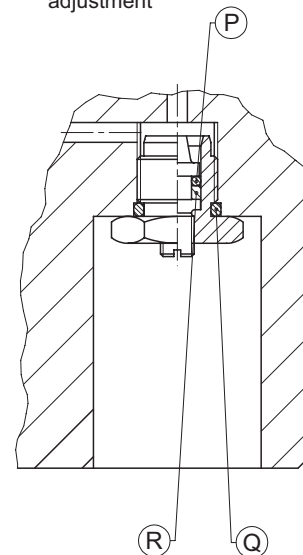

The following tables describe the procedure for ordering complete spare seals kit:

Tab.10 - Complete seals kit for T9 series (designed to take magnetostrictive transducer)

Features	Description	Code
<b>Kit series</b>	Complete seals kit for T9 cylinders compliant with ISO 6022 standards	K9
<b>Bore</b>	Specify bore in mm	-
<b>Rod</b>	Specify rod diameter by letter (see cylinder ordering code at page 2)	A
<b>Seals type</b>	Normal (Nitrile rubber, Polyurethane, PTFE charged bronze)	19
	High temperature and/or aggressive fluid (Fluoroelastomer, PTFE charged bronze)	18*
	Water and glycol mixtures (Nitrile rubber, PTFE charged bronze)	6
	Low friction (Nitrile rubber, PTFE charged bronze)	13
	Heavy application (Nitrile rubber, charged nitrile rubber cotton fabric)	22

Seals ordering code

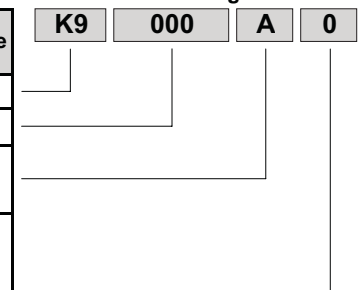

\* Maximum working temperature: 70 °C

## Standard and large-sized connections

The cylinders in the 09 series are supplied with BSP screw-threaded cylindrical connections with housing for sealing washers. In the event that it is necessary to use oil inlets different from the ones illustrated in the sizing tables of this catalogue, larger-sized connections, SAE flange couplings and screw threading not covered by ISO 6022 standards are available. The table below gives all the possible inlet connections available for the 09 series.

Bore Ø mm	Rod Ø mm	Oil inlets thread										
		Standard	On request									
		BSP	Metric	NPT	UNF-2B	SAE Flange 3000 PSI	SAE Flange 6000 PSI	BSP	Metric	NPT	UNF-2B	SAE Flange 3000 PSI
50	32	1/2"	M22x1,5	1/2"	3/4" - 16	-	-	3/4"	M27x1,5	3/4"	1" 1/16 - 12	-
	36											
63	40	3/4"	M27x2	3/4"	1" 1/16 - 12	1/2"	1/2"	1"	M33x2	1"	1" 5/16 - 12	-
	45											
80	50	3/4"	M27x2	3/4"	1" 1/16 - 12	1/2"	1/2"	1"	M33x2	1"	1" 5/16 - 12	3/4"
	56											
100	63	1"	M33x2	1"	1" 5/16 - 12	3/4"	3/4"	1" 1/4	M42x2	1" 1/4	1" 5/8 - 12	1"
	70											
125	80	1"	M33x2	1"	1" 5/16 - 12	3/4"	3/4"	1" 1/4	M42x2	1" 1/4	1" 5/8 - 12	1"
	90											
140 <sup>!</sup>	90	1" 1/4	M42x2	1" 1/4	1" 5/8 - 12	1"	1"	1" 1/2	M48x2	1" 1/2	1" 7/8 - 12	1 1/4"
	100											
160	100	1" 1/4	M42x2	1" 1/4	1" 5/8 - 12	1"	1"	1" 1/2	M48x2	1" 1/2	1" 7/8 - 12	1 1/4"
	110											
180 <sup>!</sup>	110	1" 1/4	M42x2	1" 1/4	1" 5/8 - 12	1"	1"	1" 1/2	M48x2	1" 1/2	1" 7/8 - 12	1 1/4"
	125											
200	125	1" 1/4	M42x2	1" 1/4	1" 5/8 - 12	1"	1"	1" 1/2	M48x2	1" 1/2	1" 7/8 - 12	1 1/4"
	140											
250	160	1" 1/2	M48x2	1" 1/2	1" 7/8 - 12	1" 1/4	1" 1/4	2"	M60x2	2"	2" 1/2-12	1 1/2"
	180											
320	200	2"	M60x2	2"	2" 1/2 - 12	1" 1/2	1" 1/2	-	-	-	-	2"
	220											
400	250	2"	M60x2	2"	2" 1/2 - 12	2"	2"	-	-	-	-	-
	280											

! Bore non-compliant with ISO 6022 standard.

## Single-acting cylinders

CMB cylinders are supplied as standard with double-acting function.

They may however be used as single-acting cylinders by feeding the cylinder from just one side of the piston and delegating the task of repositioning the rod to an outside load when the feeding pressure ceases to work. The unused connection must be connected to a source of external lubrication to allow lubricated air in and out of the chamber not supplied with hydraulic oil.

## Double rod cylinders

Double rod cylinders are produced using two separate rods, one screwed onto the end of the other.

As a consequence of this type of connection, on all double rod cylinders, the rod into which the other one is screwed is inevitably less resistant.

For identification purposes, the stronger rod is marked at the end with the letter "M".

CMB recommends the use of the weaker rod only for less demanding applications.



## Choice of diameter of rod

To guarantee sufficient resistance at peak loading, cylinder rods undergoing certain conditions of pushing force must be checked following the calculation procedure given below:

- Establish the mounting type and most suitable rod connection to be used for the application the cylinder is to be used for. Using the table below (Tab.11), establish the stroke factor corresponding to the conditions the cylinder is to work in.
- Calculate the basic length by multiplying the working stroke by the stroke factor determined above.
- Determine the push force by multiplying the total cross-section of the cylinder by the working pressure or by using Table 12 on page 35.
- On the diagram in Fig. 3 on page 34, find the intersection point between the coordinates relating to the pushing force and the basic length.
- The rod diameter to be chosen is the one given by the curve immediately above the previously found intersection point.
- Rods of smaller diameter than the one given by the diagram do not ensure sufficient mechanical resistance.

## Spacers

Spacers prevent the piston from hitting against the head when the rod is completely extended and guarantee the presence of a space that can be varied by the number of limiting devices inserted between the piston and cylinder head.

This enables the lever arm present between the bush and piston to be increased, thereby increasing as a consequence the rigidity of the rod. The number of spacers to be used depends on the loading conditions and the mounting style, set out in the right-hand column of the diagram in Fig. 3; each spacer has a length of 50 mm.

Remember that the dimensions of the cylinder are increased by 50 mm multiplied by the number of spacers used with respect to the figures given in the support tables. If the number of spacers required falls in the grey area, please consult our Technical Department so that a more specific cylinder can be designed to your requirements.

Example of code: **09125T2250P06/2**

Cylinder to ISO 6022 standards - bore 125 - rod 90 - working stroke 2250 - cushioning on both ends - intermediate fixed trunnion (ISO MT4) - N° 2 spacers (L=50x2=100 mm). The quotas ZB, ZJ and PJ obtained from the support tables must be increased by 100 mm due to the presence of two spacers.

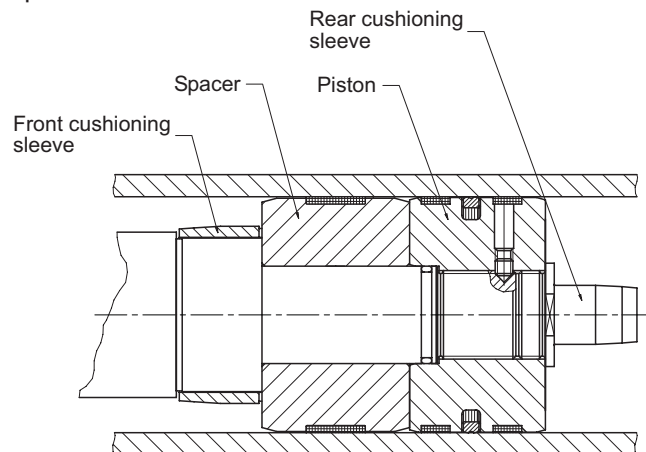

Tab. 11 - Stroke factor choice table

Mounting style	Rod connection	Mounting	Stroke factor
13	Fixed and supported		2
	Fixed and rigidly guided		0,5
	Jointed and rigidly guided		0,7
14	Fixed and supported		4
	Fixed and rigidly guided		1
	Jointed and rigidly guided		1,5

Mounting style	Rod connection	Mounting	Stroke factor
07,08	Jointed and supported		4
	Jointed and rigidly guided		2
03	Fixed and supported		2
	Fixed and rigidly guided		0,5
	Jointed and rigidly guided		0,7
06	Jointed and supported		3
	Jointed and rigidly guided		1,5

Fig. 3 - Diagram showing choice of rod

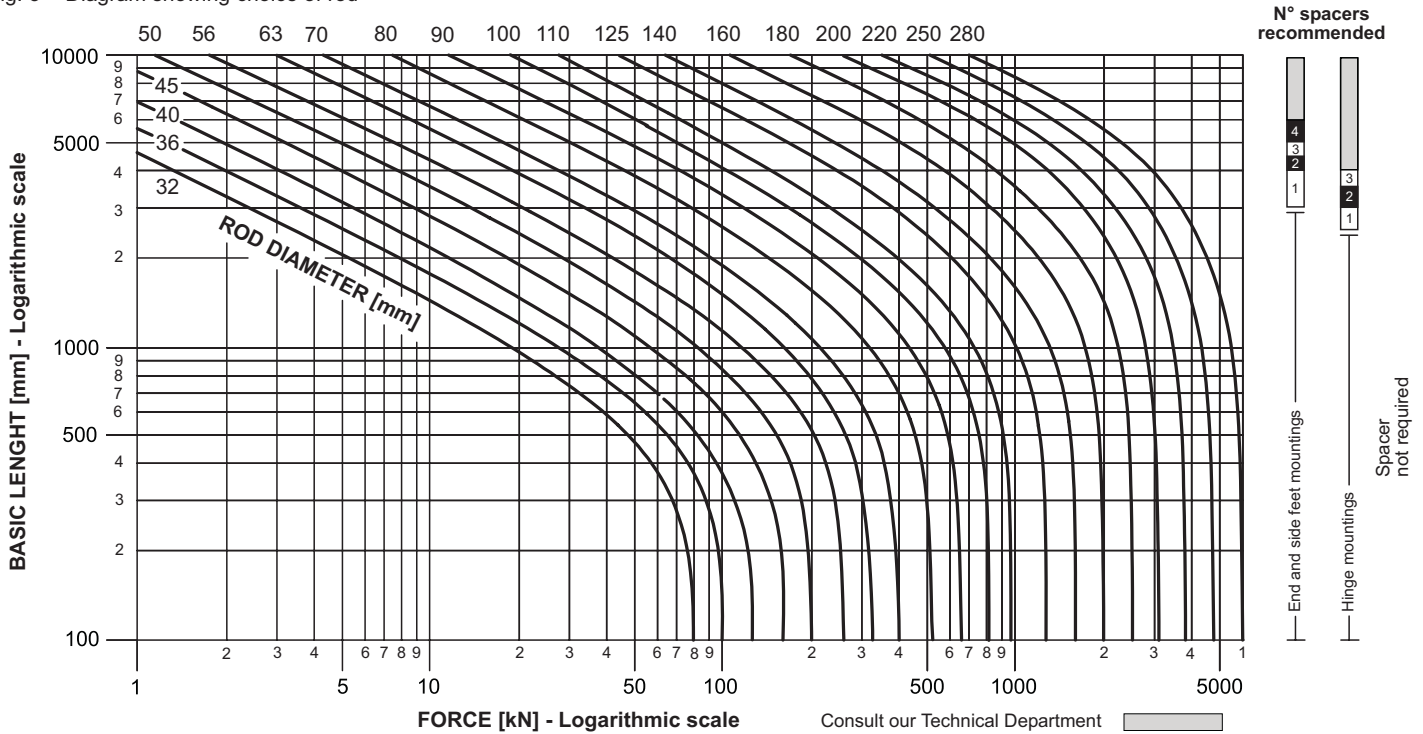

## Theoretical velocities

The drawing in Fig.4 represents the conventional hydraulic diagram of a cylinder: note how the fluid alternately feeds the front chamber through the 4/2 distributor when the rear chamber is discharging and vice versa.

The theoretical speeds generated by the cylinder can be obtained from the following correlations:

Rod speed when pushing:

$$V_s = \frac{Q \cdot 1000}{A_p \cdot 60}$$

Rod speed when pulling:

$$V_t = \frac{Q \cdot 1000}{A_a \cdot 60}$$

dove:

$V_s$  = Rod pushing speed in m/s

$V_t$  = Rod pulling speed in m/s

$Q$  = Flow rate in l/min

$A_p$  = Piston area in  $\text{mm}^2$

$A_a$  = Annular area in  $\text{mm}^2$

$A_s$  = Rod area in  $\text{mm}^2$

$Q_d$  = Flow rate through directional control valve in l/min

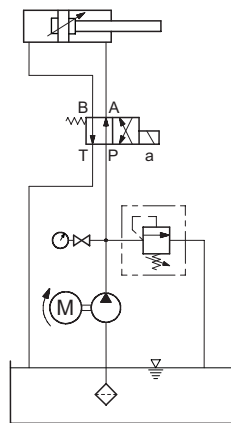

Fig. 4

The drawing in Fig.5 represents the diagram of the regenerative hydraulic circuit of a cylinder.

This diagram finds application in systems which require high speeds combined with relatively low degrees of force: note that the ring chamber is always in communication with the pump while the total chamber is connected alternately by means of the 4/2 distributor to the pump and therefore the rod protrudes by the difference in the areas or on discharge and therefore the rod re-enters.

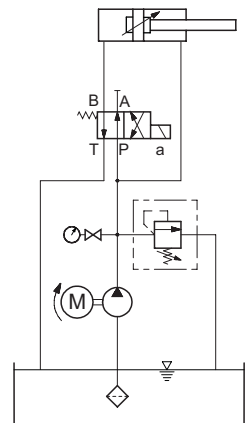

Fig. 5

The theoretical speeds generated by the cylinder can be obtained from the following correlations:

Rod speed when pushing:

$$V_s = \frac{Q \cdot 1000}{A_s \cdot 60}$$

Rod speed when pulling:

$$V_t = \frac{Q \cdot 1000}{A_a \cdot 60}$$

In installations with a regenerating circuit the distributor must be correctly sized. The capacity transiting through the distributor is calculated as follows:

$$Q_d = \frac{V_s \cdot A_p \cdot 60}{1000}$$

## Theoretical forces developed by the cylinder

When choosing a hydraulic cylinder, it is necessary to check that on the installation the nominal pressure values indicated for this series of products are not exceeded. These for continuous service are equal to 250 bar even if the sizing of the cylinders allows maximum working peaks of 320 bar to be achieved for short periods of time. Having established the load and working pressure, and after having determined the most suitable diameter of the rod to guarantee resistance at peak loads (see pages 33 and 34), the cylinder bore may be chosen from the table below by identifying the working pressure and the closest pushing or pulling force generated to the one required.

Tab. 12 - Theoretical forces developed by the cylinder

Bore Ø mm	Rod Ø mm	Working Area		50**		100**		150**		200**		250**		300**	
		Push	Pull	Push	Pull	Push	Pull	Push	Pull	Push	Pull	Push	Pull	Push	Pull
		mm <sup>2</sup>	mm <sup>2</sup>	kN*	kN*	kN*	kN*	kN*	kN*	kN*	kN*	kN*	kN*	kN*	kN*
50	32	1963,49	1159,24	9,82	5,8	19,63	11,59	29,45	17,39	39,27	23,18	49,09	28,98	58,9	34,78
	36		945,61												
63	40	3117,24	1860,6	15,59	9,3	31,17	18,61	46,76	27,91	62,34	37,21	77,93	46,52	93,52	55,82
	45		1526,8												
80	50	5026,54	3063,04	25,13	15,32	50,27	30,63	75,40	45,95	100,53	61,26	125,66	76,58	150,79	91,89
	56		2563,53												
100	63	7853,98	4736,73	39,27	23,68	78,54	47,37	117,81	71,05	157,08	94,73	196,35	118,42	235,62	142,1
	70		4005,53												
125	80	12271,84	7245,29	61,36	36,23	122,72	72,45	184,08	108,68	245,44	144,91	306,80	181,13	368,16	217,35
	90		5910,14												
140 <sup>!</sup>	90	15393,8	9032,07	76,97	45,16	153,94	90,32	230,91	135,48	307,88	180,64	384,84	225,80	461,81	270,96
	100		7539,82												
160	100	20106,18	12252,2	100,53	61,26	201,06	122,52	301,59	183,78	402,12	245,04	502,65	306,31	603,19	367,56
	110		10602,86												
180 <sup>!</sup>	110	25446,8	15943,48	127,23	79,72	254,47	159,44	381,70	239,15	508,94	318,87	636,17	398,59	763,40	478,3
	125		13174,95												
200	125	31415,90	19144,05	157,08	95,72	314,16	191,44	471,24	287,16	628,32	382,88	785,40	478,60	942,48	574,32
	140		16022,09												
250	160	49087,3	28981,1	245,44	144,91	490,87	289,81	736,31	434,72	981,75	579,62	1227,18	724,53	1472,62	869,43
	180		23640,4												
320	200	80424,78	49008,85	402,12	245,04	804,25	490,09	1206,37	735,13	1608,49	980,18	2010,62	12225,2	2412,74	1470,27
	220		42411,5												
400	250	125663,7	76576,31	628,32	382,88	1256,64	765,76	1884,95	1148,64	2513,27	1531,53	3141,59	1914,41	3769,91	2297,28
	280		64088,48												

\* 1kN = 98,067 Kg<sub>f</sub>

\*\* 1bar = 100000 Pa

! Bore non-compliant with ISO 6022 standard.

## Cushioning cones length

Bore Ø	Front cushioning cone length	Rear cushioning cone length
50	38	34
63	40	42
80	50	58
100	50	49
125	60	64
140	60	64

Bore Ø	Front cushioning cone length	Rear cushioning cone length
160	75	68
180	75	73
200	80	69
250	100	101
320	100	99
400	110	108

## End of stroke cushioning

End of stroke cushioning is provided by optional braking devices available for all bores and recommended to control deceleration at the end of stroke of the load applied to the rod when the piston speed exceeds 0.1 m/s.

End of stroke braking is in all circumstances recommended because it reduces peaks in pressure and thrust transmitted through the installation thereby guaranteeing greater resistance of the cylinder to fatigue as well as of the hydraulic devices connected to the installation.

Cushioning can be provided to the head and cap or both sides without the size of the cylinder being altered. The braking speed is adjustable by means of needle valves provided with a safety anti-expulsion system to prevent the adjustment needle from being inadvertently removed from the cartridge during adjustment operations.

In comparison with cylindrical and conical cushioning systems present on the market, CMB uses special cushioning cones with 3 tapers, sized to absorb the energy developed during the end of stroke braking in a constant way, thereby drastically reducing thrust and guaranteeing progressive braking action, bringing the pressure states in the chamber up to a value that provides ideal cushioning. For cylinders with bores greater than 160 mm fitted with suspension, the heads can be fitted on request with an additional entrance which connects directly with the braking chamber. We recommend this type of coupling connected to a maximum pressure valve set at 350 bar to limit overpressure during braking.

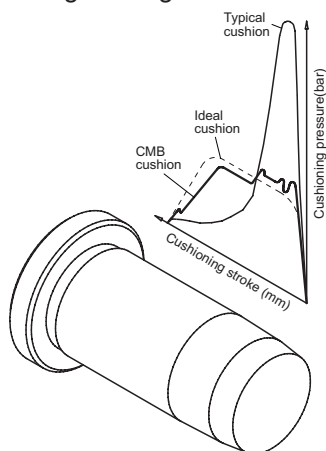

Fig. 6 - Theoretical pressure states in the braking chamber

## Air bleeds and drainage

On request air bleeds on the heads can be supplied which allow for the elimination of air generated when the whole cylinder stroke is not used or when the coupling connections are not turned upwards.

In cylinders with long strokes and regenerating circuits in which the annular combustion chamber is constantly under pressure, it is advisable to request a coupling on the front head for draining off fluid that accumulates between the first and second seal.

The size of the coupling is 1/8" BSP for bores up to 100 inclusive and 1/4" BSP for larger bores.

## Position of connections

The standard positions of the input connections (**P**), end of stroke braking (**R**), air bleeds (**S**), inductive sensors (**K**), drainage (**D**) and supplementary coupling (**Y**) for the maximum pressure valve are highlighted in bold print in Table 13 at the bottom of the page.

In the event that rotated positions are required, this must be specified during the ordering stage, indicating in the order code the letter corresponding to the type of connection (**P, R, S, K, D** or **Y**) to be rotated with respect to the standard followed by the new position side (**1, 2, 3** or **4**) of the head and coupling respectively consistent with the sides available in the table.

In the event that no specification is made in the order code, connections will be the standard ones highlighted in the table.

Esempio codifica: **09050L0200P08/CE R23S42K30D1**

Cylinder to ISO 6022 standards - bore 50 - rod 36 - stroke 200 - cushioning on both ends - rear spherical bearing (MP5) - standard oil feeder inlets side 1 (see table below) - cushioning side 2 on head and side 3 on cap - air bleeds side 4 on head and side 2 on cap - inductive sensor side 3 only on cap - standard drainage on head side 1.

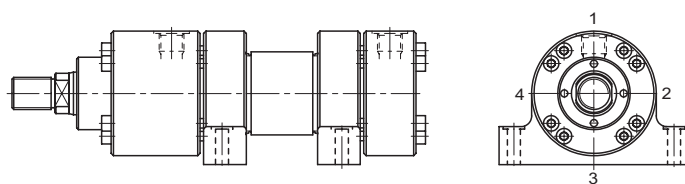

Tab. 13 - Position of available connections

	Mounting types							
	00		03		06 - 07 - 08		13 - 14	
	Head	Cap	Head	Cap	Head	Cap	Head	Cap
Oil port <b>P</b>	<b>1</b>	<b>1</b>	<b>1</b>	<b>1</b>	<b>1</b>	<b>1</b>	<b>1</b>	<b>1</b>
	2	2	2	2	2	2	2	2
	3	3	-	-	3	3	3	3
	4	4	4	4	4	4	4	4
Braking adjustment <b>R</b>	1	1	1	1	1	1	1	1
	2	2	<b>2</b>	<b>2</b>	2	2	2	2
	<b>3</b>	<b>3</b>	-	-	<b>3</b>	<b>3</b>	<b>3</b>	<b>3</b>
	4	4	4	4	4	4	4	4
Air bleeds <b>S</b>	1	1	1	1	1	1	1	1
	2	2	2	2	2	2	2	2
	3	3	-	-	3	3	3	3
	<b>4</b>	<b>4</b>	<b>4</b>	<b>4</b>	<b>4</b>	<b>4</b>	<b>4</b>	<b>4</b>
Inductive sensors <b>K</b>	1	1	1	1	1	1	1	1
	<b>2</b>	<b>2</b>	2	2	<b>2</b>	<b>2</b>	<b>2</b>	<b>2</b>
	3	3	-	-	3	3	3	3
	4	4	<b>4</b>	<b>4</b>	4	4	4	4
Drainage <b>D</b>	<b>1</b>	-	<b>1</b>	-	<b>1</b>	-	<b>1</b>	-
	2	-	2	-	2	-	2	-
	3	-	-	-	3	-	3	-
	4	-	4	-	4	-	4	-
Optional coupling <b>Y</b>	1	1	-	-	1	1	1	1
	2	2	-	-	2	2	2	2
	3	3	-	-	3	3	3	3
	<b>4</b>	<b>4</b>	-	-	<b>4</b>	<b>4</b>	<b>4</b>	<b>4</b>

## DIMENSIONS OF ROD ENDS

Standard thread rod end

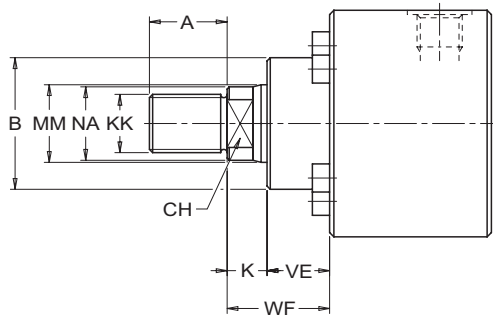

Style w: female thread rod end

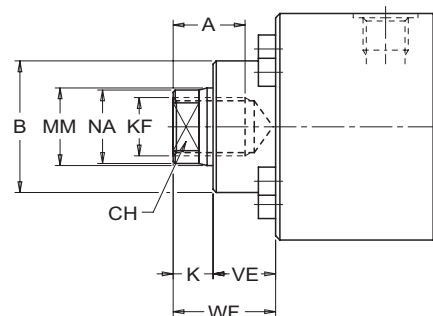

### Rod ends

ISO 6022 series cylinders are available with both male and female rod ends in accordance with ISO 4395 - 91 standard.

Non-regulation screw threading such as Whitworth, British Standard and American Standard Unified are also available.

On request rod ends can be produced from drawings by attaching a sketch with the sizes to be produced to the cylinder order.

### Area for tightening with tools

Rods with a diameter of less than 110 mm inclusive have a flat area at the end to facilitate tightening the accessory connected to the rod using an adjustable wrench with CH opening.

Rods with a diameter of more than 125 mm inclusive are provided instead with N° 4 holes  $\varnothing$  NA indicated in the tablet to allow for tightening using a UNI 6752 - DIN 1810 hook wrench with round nose end.

Bore $\varnothing$	MM $\varnothing$	A	B <sup>fb</sup> $\varnothing$	K	VE	WF	NA $\varnothing$	CH	KK (Metric)	KF (Metric)
50	32	36	63	18	29	47	31	28	M27x2	Not available
	35						32	M27x2		
63	40	45	75	21	32	53	38	34	M33x2	Not available
	43						36	M33x2		
80	50	56	90	24	36	60	48	43	M42x2	Not available
	54						46	M42x2		
100	63	63	110	27	41	68	60	53	M48x2	Not available
	67						60	M48x2		
125	80	85	132	31	45	76	77	65	M64x3	Not available
	87						75	M64x3		
140 <sup>!</sup>	90	90	145	31	45	76	87	75	M72x3	Not available
	100						85	M72x3		
160	100	95	160	35	50	85	96	85	M80x3	Not available
	110						95	M80x3		
180 <sup>!</sup>	110	105	185	40	55	95	106	95	M90x3	Not available
	125						$\varnothing$ 12	M90x3		
200	125	112	200	40	61	101	121	$\varnothing$ 12	M100x3	Not available
	140						$\varnothing$ 12	M100x3		
250	160	125	250	42	71	113	155	$\varnothing$ 15	M125x4	Not available
	180						$\varnothing$ 15	M125x4		
320	200	160	320	48	88	136	195	$\varnothing$ 15	M160x4	Not available
	220						$\varnothing$ 15	M160x4		
400	250	200	400	53	110	163	245	$\varnothing$ 20	M200x4	Not available
	280						$\varnothing$ 20	M200x4		

! Bore non-compliant with ISO 6022 standard.  
All dimensions are given in millimetres.

## KatCMB

**KatCMB** is the new multi-media technical catalogue produced by CMB to simplify the composition of codes and drawing up of cylinder designs to ISO 6020/2 and ISO 6022 standards.

As well as guiding the Customer in the choice and composition of cylinder codes, the programme is able to generate CAD drawings which may be imported and if necessary customised by means of various CAD applications thanks to the DXF graphic interchange file.

To request **KatCMB** or obtain more detailed information about the product, contact our Marketing Service.

## Index

Page

### PRESENTATION AND COMPOSITION OF CYLINDER CODES

Presentation.....	1
Technical features.....	1
How to order a CMB 09 series cylinder.....	2
Seals and hydraulic fluids.....	3
Mountings choice for the 09 series.....	4
Main categories of mounting types.....	4
Side foot mounting.....	4
End mounting.....	4
Hinge mounting.....	4
Double rod cylinders mounting.....	4

### TYPES OF MOUNTING FOR SINGLE-ROD CYLINDERS

Basic version (not to ISO standards).....	5
Side foot (not to ISO standards).....	6
Intermediate fixed trunnion (ISO MT4).....	7
Rear clevis (ISO MP3).....	8
Rear spherical bearing (ISO MP5).....	9
Front flange (ISO MF3).....	10
Rear flange (ISO MF4).....	11

### TYPES OF MOUNTING FOR DOUBLE-ROD CYLINDERS

Double rod basic version (not to ISO standards).....	12
Double rod side foot (not to ISO standards).....	13
Double rod intermediate fixed trunnion (ISO MT4).....	14
Double rod front flange (ISO MF3).....	15

### ACCESSORIES

Rod eye with spherical bearing (ISO 6982/DIN 24338).....	16
Rod eye with plain bearing (ISO 6981/DIN 24337).....	16
Fork joint hinge with pin (ISO 8133).....	17

### WEIGHTS

Weights of the 09 series.....	17
-------------------------------	----

### CYLINDERS WITH INDUCTIVE SENSORS

Inductive proximity sensors.....	18
Features of inductive sensors.....	18

### CYLINDERS WITH MAGNETOSTRICTIVE TRANSDUCER

Introduction to T9 series cylinders.....	19
Mounting type.....	19
Magnetostrictive transducer.....	19
Types of output signals available.....	19
CE mark.....	19
Rear dimensions of transducer with flying connector.....	20
Rear dimensions of transducer integral cable.....	20

## Index

Page

Types and dimensions of connector.....	20
Technical features of Linear-analog transducer.....	20
Ordering code for Linear-analog transducer.....	21
Technical features of SSI, Can-Bus and Profibus-DP transducers.....	21
Ordering code for Synchronous-Serial transducer.....	22
Ordering code for Can-Bus transducer.....	22
Ordering code for Profibus-DP transducer.....	23
Electrical connections.....	23

### STORAGE AND MAINTENANCE OF CYLINDERS

Storage and maintenance.....	23
Replacing bush seals.....	24

### EXPLODED VIEWS SHOWING MECHANICAL PARTS AND SEALS

Exploded view showing 09 series cylinders mechanical spare parts.....	25
Spare seals kit for standard 09 series cylinders and for 09 series with inductive sensors.....	26
Exploded view showing mechanical spare parts for 09 series double rod cylinders.....	27
Spare seals kit for standard 09 series double rod cylinders and for 09 series double rod with inductive sensors.....	28
Exploded view showing mechanical spare parts for 09 series double rod cylinders with inductive sensors.....	29
Exploded view showing T9 series cylinders mechanical spare parts.....	30
Spare seals kit for standard T9 series cylinders.....	31

### CHOICE AND SIZING OF CYLINDERS

Standard and large-sized connections.....	32
Single-acting cylinders.....	32
Double rod cylinders.....	32
Choice of diameter of rod.....	33
Spacers.....	33
Theoretical velocities.....	34
Theoretical forces developed by the cylinder.....	35
Cushioning cones length.....	35
End of stroke cushioning.....	36
Air bleeds and drainage.....	36
Position of connections.....	36
Dimensions of rod ends.....	37
Rod ends.....	37
Area for tightening with tools.....	37
<b>KatCMB</b> - multi-media technical catalogue.....	38

Visit us at our Internet site  
[www.cmbcilindri.com](http://www.cmbcilindri.com)

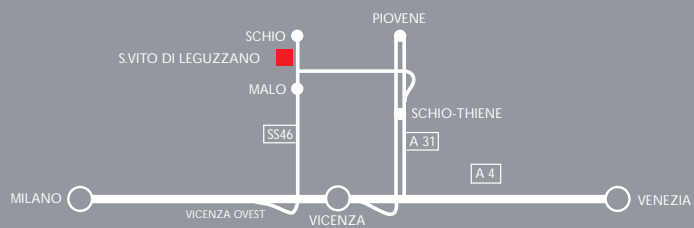

**CMB S.r.l.** - Via Vicenza, 17  
36030 S.Vito di Leguzzano (VI) Italy  
Tel +39 0445 519555 r.a.  
Fax +39 0445 519481  
[www.cmbcilindri.com](http://www.cmbcilindri.com)  
[info@cmb-cil.com](mailto:info@cmb-cil.com)