

VAM 750

Speed Control

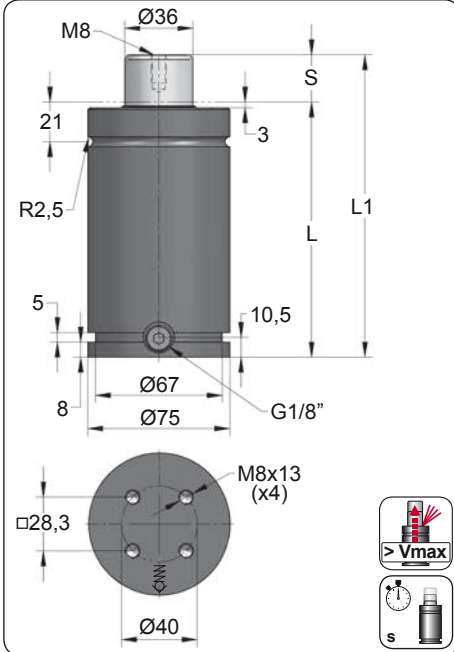

ORDER	S (mm)	L1 ±0,25 (mm)	L (mm)	Kg.
VAM 750 025	25	160	135	3.47
VAM 750 038	38	186	148	3.71
VAM 750 050	50	210	160	3.92
VAM 750 063	63.5	237	173.5	4.17
VAM 750 080	80	270	190	4.46
VAM 750 100	100	310	210	4.82
VAM 750 125	125	360	235	5.27

$t_{max} = k \times S_U$

	k
VAM 750	0.062

Max. delay time (t_{max})
Constant (k)
Stroke used (S_U)

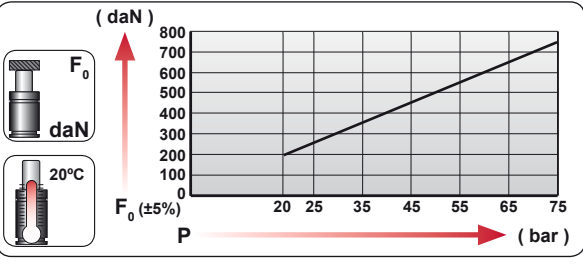

CODE	Pressure		Force	
	bar	psi	daN	daN
VAM 750	75	1088	760	1010

-Slight initial return back depends on the stroke used.
-Return at constant slowed speed.

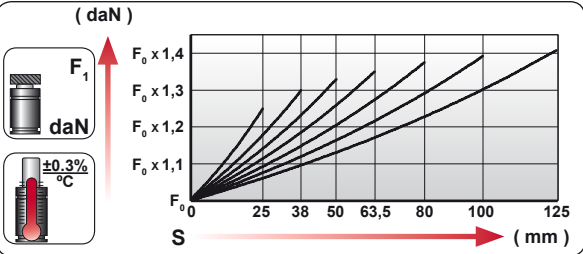

ENG ORDER	DEU BESTELLUNG	FRA COMMANDE	ITA ORDINE	ESP PEDIDO	POR PEDIDO
-----------	----------------	--------------	------------	------------	------------

VAM 750 50

VAM 750 050

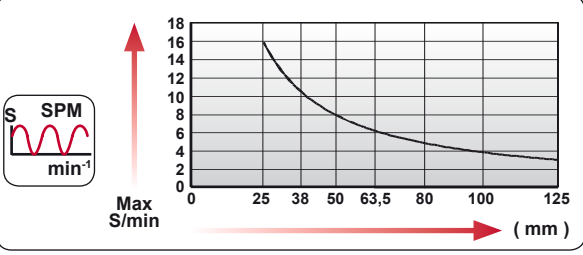

	$S_{max} < 90\%$	$V_{max} 0,5 \text{ m/s}$	$P_{min} (20^\circ\text{C})$	$P_{max} (20^\circ\text{C})$	T_{min}	T_{max}	
--	------------------	---------------------------	------------------------------	------------------------------	-----------	-----------	--

N ₂	$S_{max} < 90\%$	$V_{max} 0,5 \text{ m/s}$	bar psi	bar psi	°C °F	°C °F	600 CP-
			20 290	75 1088	0 32	80 176	

CONVENTIONAL

Stroke

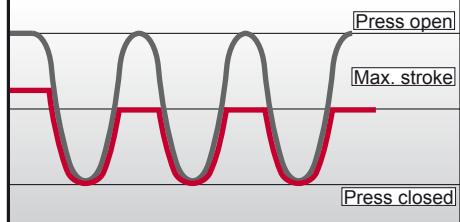

Time

VAM

Stroke

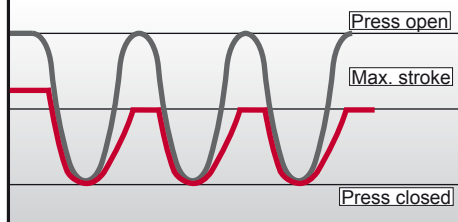

Time

DATA REQUIRED



• Desired force (daN):.....



• Total stroke (mm):.....



• Stroke used (mm):.....



• Number of cycles per minute:.....



• Desired delay time (eg. 1 second):.....

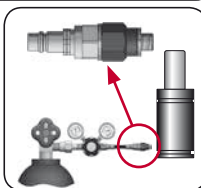
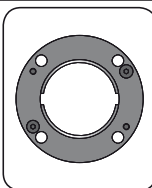
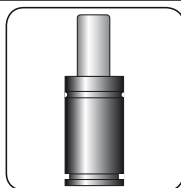

CODE	VAM 750 050	KIT S-XXXXXXX KIT C-XXXXXXX	A14-075	18 CG 1-Q
ENG ORDER	GAS SPRING	REPAIR KIT	FLANGE	CHARGING ADAPTER
DEU BESTELLUNG	GASDRUCKFEDER	ERSATZTEILSATZ	FLANSCHEN	LADEADAPTER
FRA COMMANDE	RESSORT À GAZ	KIT DE RÉPARATION	BRIDE	RACCORD DE CHARGE
ITA ORDINE	CILINDRO AD AZOTO	KIT DI MANUTENZIONE	FLANGE	ADATTATORE DI CARICO
ESP PEDIDO	RESORTE DE GAS	KIT DE REPARACION	BRIDA	ADAPTADOR DE CARGA
POR PEDIDO	CILINDRO DE GÁS	KIT DE MANUTENÇÃO	FLANGE	ADAPTADOR DE CARGA

VAM 750 MOUNTS

Speed Control

AZOL
GAS

A14-075

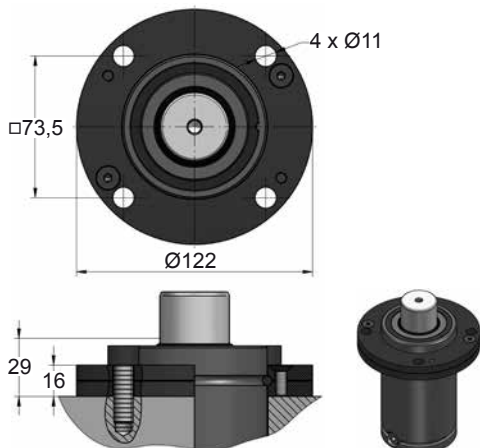

A34-075

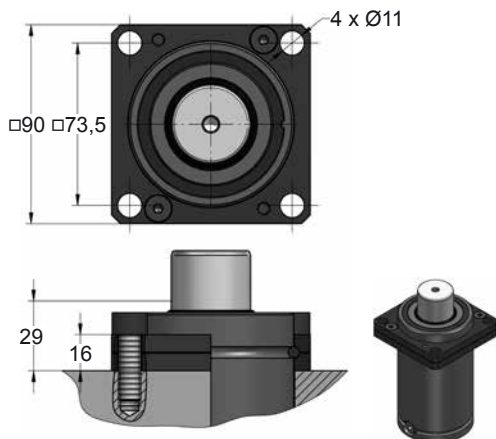

B21-075

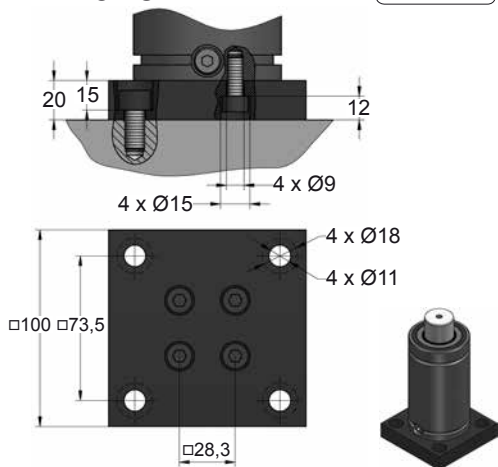

B76-075

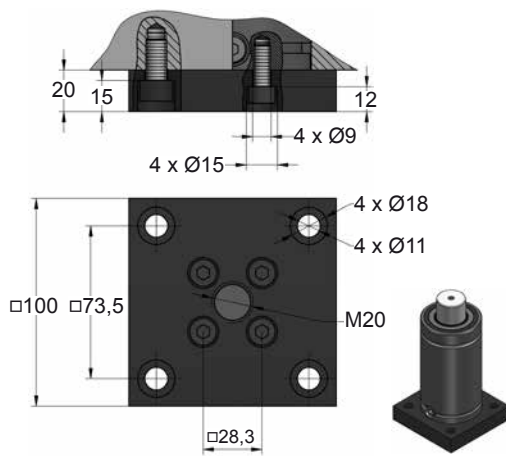

SEAL

KIT S-XXXXXXX

CARTRIDGE

KIT C-XXXXXXX

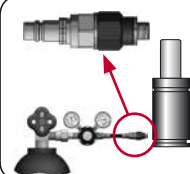
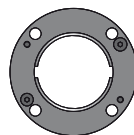

CODE	VAM 750 050	KIT S-XXXXXXX KIT C-XXXXXXX	A14-075	18 CG 1-Q
ENG ORDER	GAS SPRING	REPAIR KIT	FLANGE	CHARGING ADAPTER
DEU BESTELLUNG	GASDRUCKFEDER	ERSATZTEILSATZ	FLANSCHEN	LADEADAPTER
FRA COMMANDE	RESSORT À GAZ	KIT DE RÉPARATION	BRIDE	RACCORD DE CHARGE
ITA ORDINE	CILINDRO AD AZOTO	KIT DI MANUTENZIONE	FLANGE	ADATTATORE DI CARICO
ESP PEDIDO	RESORTE DE GAS	KIT DE REPARACION	BRIDA	ADAPTADOR DE CARGA
POR PEDIDO	CILINDRO DE GAS	KIT DE MANUTENÇÃO	FLANGE	ADAPTADOR DE CARGA



VAM 750 MOUNTS

Speed Control

C05-075

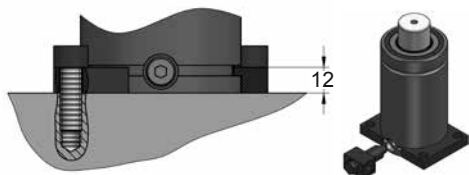
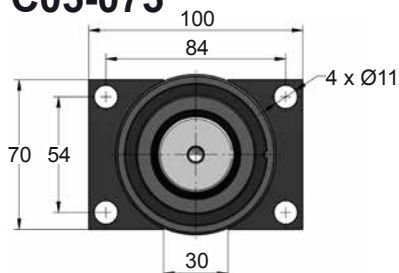

C20-075

ISO 9001 VDI E24.54.815.G EM24.54.700F

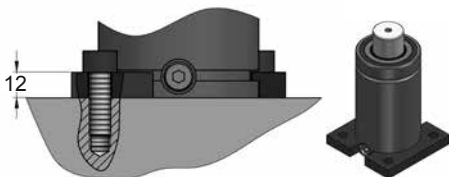
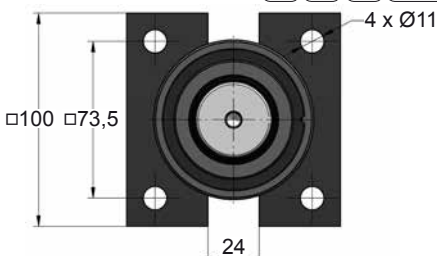

D02-075

2 x Ø11

ISO 9001 E24.54.815.G EM24.54.700F

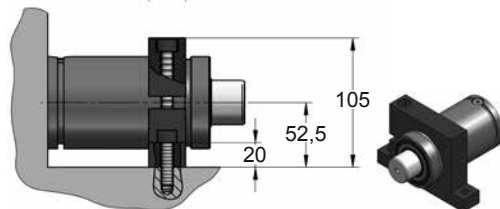
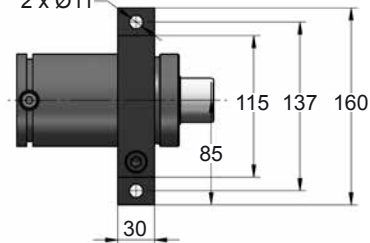

D67-075

VDI

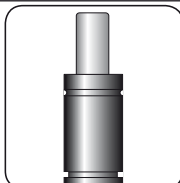
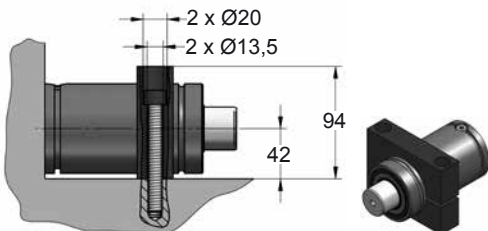
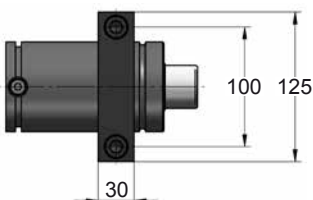

SEAL KIT S-XXXXXXX



CARTRIDGE KIT C-XXXXXXX

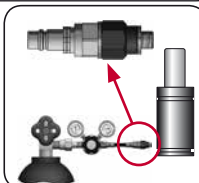
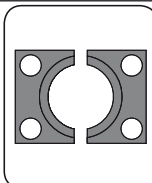

CODE	VAM 750 050	KIT S-XXXXXXX KIT C-XXXXXXX	C05-075	18 CG 1-Q
ENG ORDER	GAS SPRING	REPAIR KIT	FLANGE	CHARGING ADAPTER
DEU BESTELLUNG	GASDRUCKFEDER	ERSATZTEILSATZ	FLANSCHEN	LADEADAPTER
FRA COMMANDE	RESSORT À GAZ	KIT DE RÉPARATION	BRIDE	RACCORD DE CHARGE
ITA ORDINE	CILINDRO AD AZOTO	KIT DI MANUTENZIONE	FLANGE	ADATTATORE DI CARICO
ESP PEDIDO	RESORTE DE GAS	KIT DE REPARACION	BRIDA	ADAPTADOR DE CARGA
POR PEDIDO	CILINDRO DE GÁS	KIT DE MANUTENÇÃO	FLANGE	ADAPTADOR DE CARGA