

CP-KC 1000 V1

Heavy Load

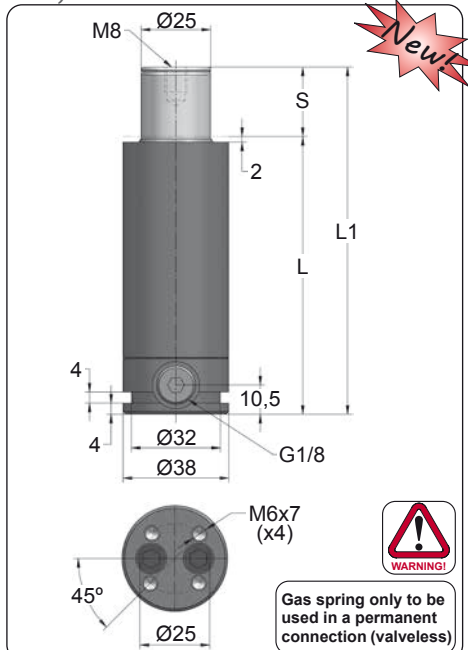

ORDER	S (mm)	L1 ±0,25 (mm)	L (mm)	Kg.
CP-KC 1000 010 V1	10	95	85	0.58
CP-KC 1000 015 V1	15	105	90	0.61
CP-KC 1000 025 V1	25	125	100	0.66
CP-KC 1000 038 V1	38	155	117	0.74
CP-KC 1000 050 V1	50	180	130	0.80
CP-KC 1000 063 V1	63	225	162	0.92
CP-KC 1000 080 V1	80	260	180	1.01



Gas spring only to be used in a permanent connection (valveless)

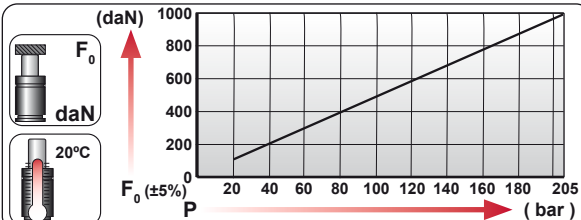

CODE	Pressure Gauge	bar	psi	F ₀ daN	F ₁ daN
CP-KC 1000 050 V1		0	0	---	---

ENG Gas spring only to be used in a permanent connection (valveless)
 DEU Gasdruckfeder kann nur im Verbund eingesetzt werden (ohne Ventil)
 FRA Ressort à gaz ne peut être utilisé que relié dans une connexion (sans valve)
 ITA Cilindro può essere utilizzato solo in una connessione permanente (senza valvola)
 ESP Cilindro de gas sólo puede ser usado en un sistema conexionado (sin válvula)
 POR Cilindro de gás apenas pode ser utilizado em um sistema interligado (sem válvula)

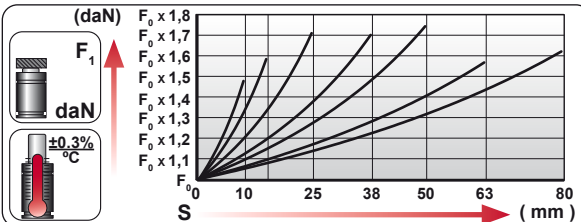

Language	ORDER	F ₀ daN	S mm
ENG	CP-KC 1000	50	
DEU	BESTELLUNG		
FRA	COMMANDE		
ITA	ORDINE		
ESP	PEDIDO		
POR	PEDIDO		

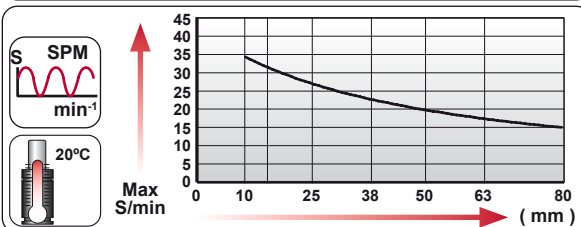





--	--	--	--	--	--	--	--

N ₂	Smax < 90%	Vmax 0,5 m/s	bar psi	bar psi	°C °F	°C °F	600 CP-
			20 290	205 2975	0 32	80 176	

ONLY PERMANENT HOSED GAS SPRINGS



CODE				
	bar	psi	daN	daN
-----	---	---	---	---
CP-KC 1000 050 V1	0	0	---	---

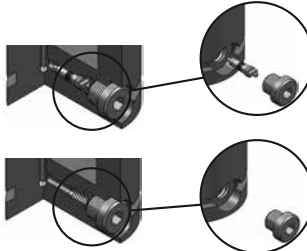

ENG	Hosed gas spring	Gas spring delivered unfilled and it can only be used in a permanent connection (valveless)
DEU	Gasdruckfeder zum verschlauchen	Gasdruckfeder wird drucklos angeliefert und kann nur im Verbund eingesetzt werden (ohne Ventil)
FRA	Ressort à gaz relié	Ressort à gaz fourni non chargé et il ne peut être utilisé que relié dans une connexion permanente (sans valve de charge)
ITA	Cilindro collegabile	Cilindro fornito scarico e può essere utilizzato solo in una connessione permanente (senza valvola unidirezionale)
ESP	Cilindro conexionable	Cilindro de gas suministrado descargado y sólo puede ser usado en un sistema conexionado permanente (sin válvula de carga)
POR	Cilindro de gas interligado	Cilindro de gás fornecido descarregado, apenas pode ser utilizado em um sistema interligado permanente (sem válvula de carga)

C20-038



E24.54.815.G
EM24.54.700.F

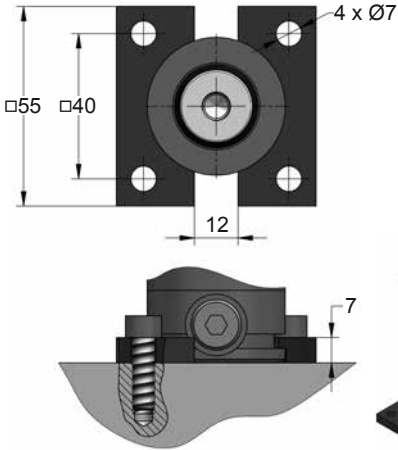

KC 1000

Gas spring only to be used in a permanent connection (valveless)

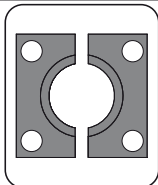
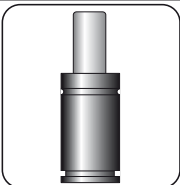
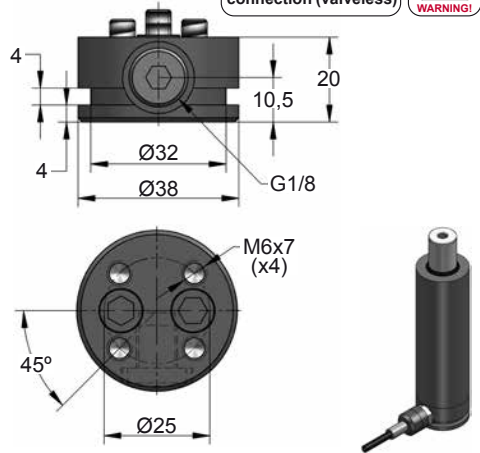

CODE	CS-KC 1000 050 V1	KIT S-XXXXXXX	C20-038	SKK 12R 1/8
ENG	ORDER	GAS SPRING	FLANGE	CHARGING ADAPTER
DEU	BESTELLUNG	GASDRUCKFEDER	FLANSCH	LADEADAPTER
FRA	COMMANDE	RESSORT À GAZ	BRIDE	RACCORD DE CHARGE
ITA	ORDINE	CILINDRO AD AZOTO	FLANGE	ADATTATORE DI CARICO
ESP	PEDIDO	RESORTE DE GAS	BRIDA	ADAPTADOR DE CARGA
POR	PEDIDO	CILINDRO DE GÁS	FLANGE	ADAPTADOR DE CARGA