

# CK 200 V1

Low Profile

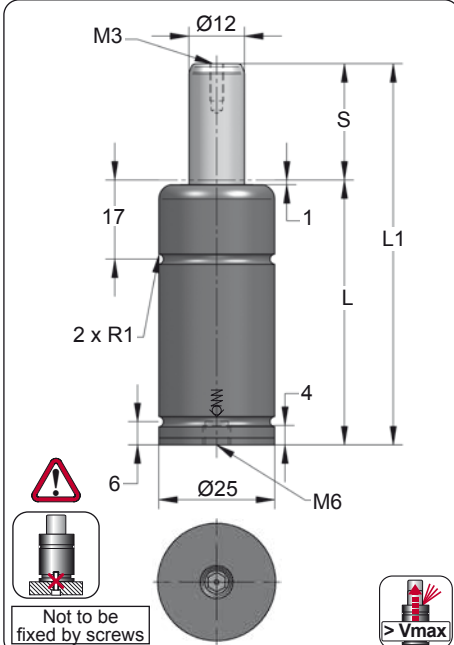

ORDER	S (mm)	L1 ±0,25 (mm)	L (mm)	Kg.
CK 200 007 V1	7	46	39	0.11
CK 200 010 V1	10	52	42	0.12
CK 200 012 V1	12.7	57.4	44.7	0.12
CK 200 016 V1	16	64	48	0.13
CK 200 019 V1	19	70	51	0.13
CK 200 025 V1	25	82	57	0.15
CK 200 032 V1	32	96	64	0.16
CK 200 038 V1	38	108	70	0.17
CK 200 050 V1	50	132	82	0.19
CK 200 063 V1	63.5	159	95.5	0.22
CK 200 080 V1	80	192	112	0.25
CK 200 100 V1	100	232	132	0.29



CODE	Pressure Gauge	bar	psi	F <sub>0</sub> daN	F <sub>1</sub> daN
CK 200 050 V1		170	2465	190	280
-----	-----	-----	-----	-----	-----

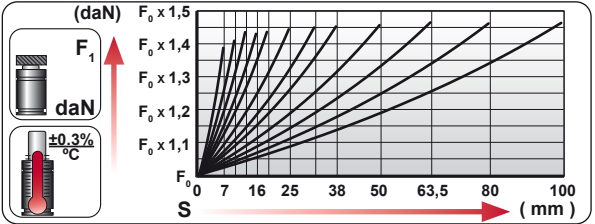
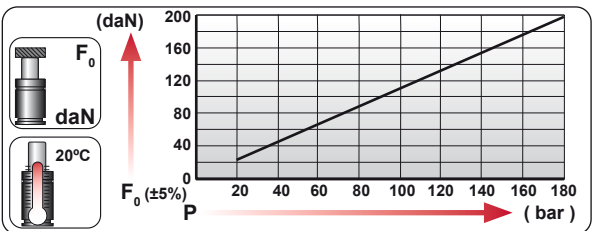

ENG ORDER  
 DEU BESTELLUNG  
 FRA COMMANDE  
 ITA ORDINE  
 ESP PEDIDO  
 POR PEDIDO

F<sub>0</sub> daN  
 S mm

**CK 200 50**  
**CK 200 050 V1**

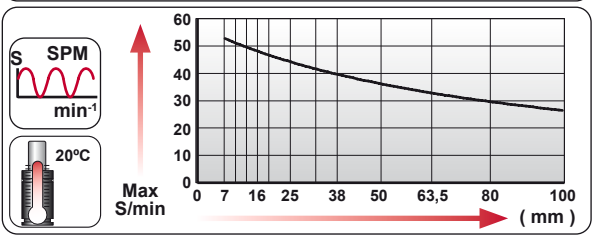

N <sub>2</sub>	Smax < 90%	Vmax 1,6 m/s	bar psi	bar psi	°C °F	°C °F	
			20 290	180 2610	0 32	80 176	

# CK 200 V1 MOUNTS

Low Profile

## A14-025

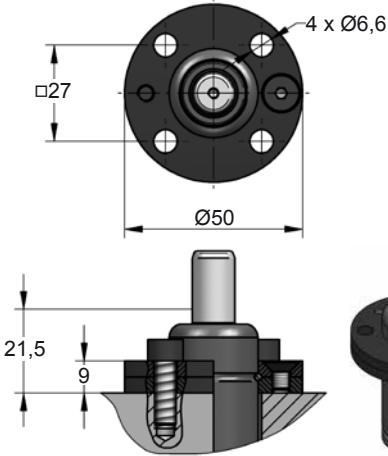

## A19-025

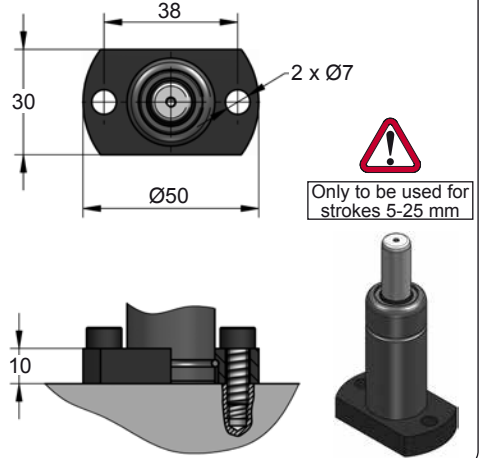

## A44-025

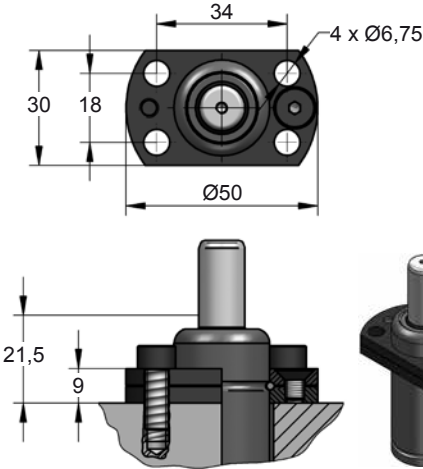

## A49-025

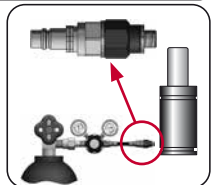
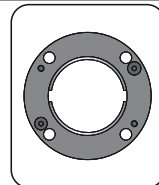
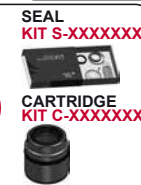
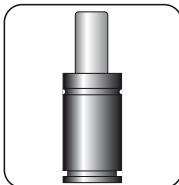
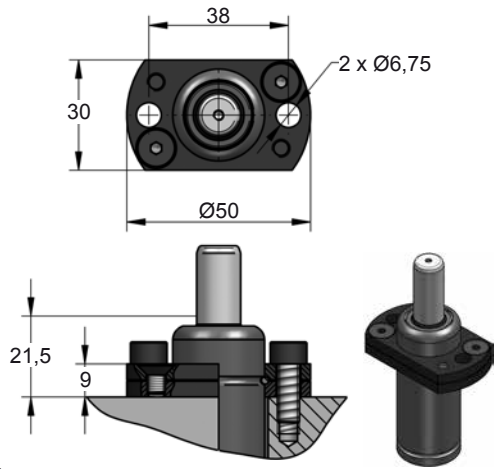

CODE	CK 200 050 V1	<b>X</b>	A14-025	06 CG 2-Q
ENG ORDER	GAS SPRING	REPAIR KIT	FLANGE	CHARGING ADAPTER
DEU BESTELLUNG	GASDRUCKFEDER	ERSATZTEILSATZ	FLANSCHEN	LADEADAPTER
FRA COMMANDE	RESSORT À GAZ	KIT DE RÉPARATION	BRIDE	RACCORD DE CHARGE
ITA ORDINE	CILINDRO AD AZOTO	KIT DI MANUTENZIONE	FLANGE	ADATTATORE DI CARICO
ESP PEDIDO	RESORTE DE GAS	KIT DE REPARACION	BRIDA	ADAPTADOR DE CARGA
POR PEDIDO	CILINDRO DE GAS	KIT DE MANUTENÇÃO	FLANGE	ADAPTADOR DE CARGA