

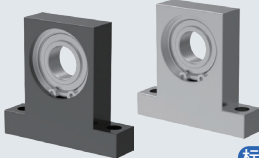

★ 产品特点: 最适用于前后空间小的情况。可以1mm为单位指定高度。



标准加工

按图定制

①代号	M材质		S表面处理	A附件
	轴承	固定座	固定座	挡圈
HATBAK	钢	一般结构用钢	四氧化三铁保护膜	弹簧钢
HATEAK			无电解镀锌	
HATCAK		铝合金	本色阳极氧化	不锈钢
HATGAK				
HATNAK	不锈钢	-		

▲ 如果对防锈性能有要求, 请优先选用无电解镀锌表面处理、铝合金材质和不锈钢材质产品。
 ▲ 由于产品批次不同, 发货表面处理产品可能存在色差, 不影响尺寸及功能。
 ▲ 固定座一般结构用钢和不锈钢材质带有防锈油。

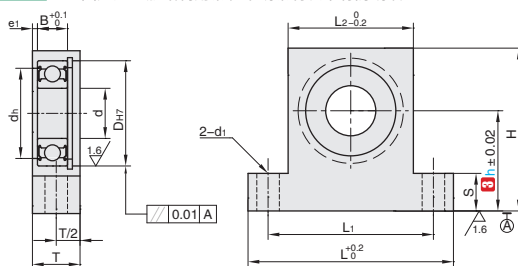

视角标准: 第一视角

①代号 - ②轴承型号 - ③中心高h - ④追加加工类型

HATBAK - 6900ZZ - h15 - MTC

①代号	②轴承型号	③中心高h 指定单位 1mm	d	H	L ₁	d ₁	L	L ₂	T	S	d _h	D _{h17}	H7公差	B	e ₁
	623ZZ	10 ~ 30	3	h+9	26	4.5	36	16	10	5	7	10	+0.015 0	4	
	624ZZ		4	h+11	28		38	18			9	13			
	605ZZ	15 ~ 30	5	h+12	30	40	20	10	14	+0.018 0	5				
	625ZZ		5	h+13	34	46	22	12	16						
	606ZZ	20 ~ 40	6	h+14	35	47	23	12	17		+0.021 0	6			
	626ZZ		6	h+14	37	49	25	15	19						
	698ZZ	25 ~ 50	8	h+14	37	49	25	11	16		19	6			
	608ZZ		8	h+15	41	53	29	12	18	22	7				
	628ZZ	30 ~ 60	10	h+16	44	56	32	15	20	24	8				
	6800ZZ		10	h+14	38	50	26	10	16	19	5				
	6900ZZ	35 ~ 100	10	h+15	41	53	29	12	19	22	6		+0.021 0	6	
	6000ZZ		10	h+17	46	58	34	15	22	26	8				
	6200ZZ	40 ~ 80	12	h+19	50	62	38	15	24	30	9				
	6801ZZ		12	h+15	41	53	29	10	18	21	5				
	6901ZZ	45 ~ 120	12	h+16	44	56	32	12	21	24	6				
	6001ZZ		12	h+18	48	60	36	15	24	28	8				
	6201ZZ	50 ~ 150	15	h+20	52	64	40	16	26	32	+0.025 0		10		
	6802ZZ		15	h+16	44	56	32	10	21	24	5				
	6902ZZ	55 ~ 180	15	h+18	48	60	36	12	25	28	+0.021 0		7	2	
	6002ZZ		15	h+20	54	68	40	15	28	32	9				
	6202ZZ	60 ~ 200	17	h+22	58	72	44	16	29	35	+0.025 0		11		
	6903ZZ		17	h+19	52	64	38	13	27	30	+0.021 0	7			
	6003ZZ	65 ~ 240	17	h+22	56	70	43	16	31	35	+0.025 0	10			
	6203ZZ		17	h+24	62	76	49	19	34	40	12				
	6804ZZ	70 ~ 280	20	h+20	53.5	68	40	13	29	32	7				
	6904ZZ		20	h+23	59	73	45	15	34	37	9				
	6004ZZ	75 ~ 320	20	h+25	66	82	50	19	36	42	+0.025 0		12		
	6204ZZ		20	h+28	72	88	56	19	40	47	14				
	6805ZZ	80 ~ 360	25	h+23	64	82	46	13	34	37	7				
	6905ZZ		25	h+25	69	91	51	15	39	42	9				
	6005ZZ	85 ~ 400	25	h+28	76	96	56	19	41	47	12				
	6205ZZ		25	h+31	82	102	62	22	45	52	+0.030 0	15			
	6806ZZ	90 ~ 450	30	h+25	71	91	51	14	39	42	7				
	6906ZZ		30	h+28	76	96	56	16	44	47	+0.025 0		9		
	6006ZZ	95 ~ 500	30	h+32	84	104	64	19	48	55	13				
	6206ZZ		30	h+36	92	112	72	22	55	62	16				
	6007ZZ	100 ~ 600	35	h+36	92	112	72	21	55	62	14				
	6207ZZ		35	h+44	118	13	148	88	26	64	72		+0.030 0	17	
	6008ZZ	105 ~ 700	40	h+41	102	11	122	82	24	20	60	68	15	3	
	6208ZZ		40	h+50	130	13	160	100	27	25	74	80	18		

▲ 在轴承与挡圈之间会产生间隙, 选型时请注意。
 ▲ 爱安特不承诺轴承的品牌。