

平键

★ 产品特点：键的侧面为工作面，对中性好，方便拆卸。

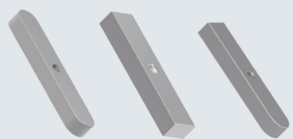

①代号	类型	④材质
FKACJ	A型	45#
FKBCJ	B型	
FKCCJ	C型	

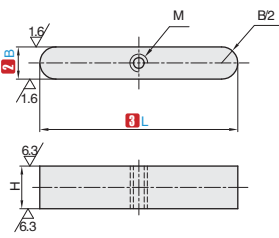

FKACJ
A型

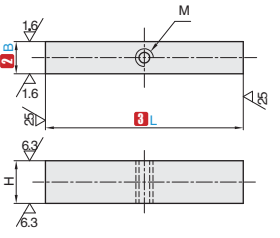

FKBCJ
B型

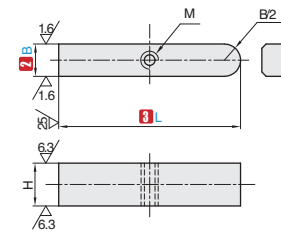

FKCCJ
C型

视角标准：第一视角



①代号 - ②B - ③L
FKACJ - B5 - L20

①代号	②B	公差 h9	③L											C	H容差		M 粗牙 螺纹	
			10	15	20	25	30	35	40	45	50	55	60		5	6		
FKACJ	5	0	10	15	20	25	30	35	40	45	50	0.25 ~ 0.40	5	0	M3			
	6	-0.030	10	15	20	25	30	35	40	45	50		55	60		6	-0.030	
	7	0	15	20	25	30	35	40	45	50	60	7	-0.036					
FKBCJ	8	-0.036	15	20	25	30	35	40	45	50	55	60	70	80	0.40 ~ 0.60	8	0	M4
	10	0	15	20	25	30	35	40	45	50	55	60	70	80		9	-0.090	
FKCCJ	12	0	20	25	30	35	40	45	50	55	60	70	80	0.40 ~ 0.60	10	0	M5	
	14	0	30	35	40	45	50	55	60	70	80	90	9		-0.090			
	15	0	30	35	40	45	50	55	60	70	80	90	10		-0.110			
	16	-0.043	40	45	50	55	60	70	80	90	100	11	0	M6				
18	0	40	45	50	55	60	70	80	90	100	110	11	-0.110					

L	公差
≤10	0 -0.15
11 ~ 15	0 -0.18
16 ~ 30	0 -0.21
31 ~ 50	0 -0.25
51 ~ 80	0 -0.30
81 ~ 110	0 -0.35

K1 平键/挡圈/开口销
圆柱销/油嘴