

45钢双膜片免键式联轴器



★ 产品特点：零回转间隙，适用于正反转，具有良好的耐磨性、腐蚀性、耐油性和电气绝缘性。



CAD
2D 3D

①代号	主体M材质	弹性体M材质	S表面处理
CPLNSZ	45 钢	SUS304 不锈钢	四氧化三铁保护膜

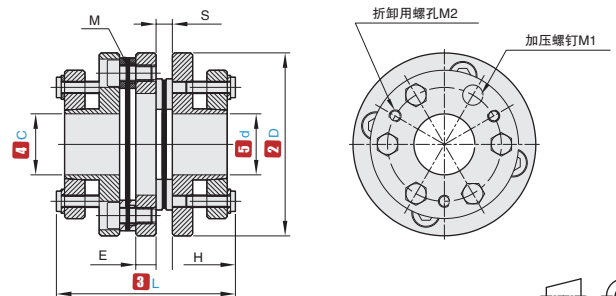

△c和d开口加工前的公差为H8。

视角标准：第一视角



①代号 - ②D - ③L - ④c - ⑤d
CPLNSZ - 70 - 80 - c18 - d20

①代号	②D	③L	④c⑤d 可选范围	H	E	S	M	M1	M2	
CPLNSZ	56	80	14 16 18 20 22 24	29	8	7	M5	M5	M5	
	70	80	18 20 22 24 25 28 30 32 35	29						
	70L	105	18 20 22 24 25 28 30 32 35	41.5						
	80	88	18 20 22 24 25 28 30 32 35	31	10	8	M6	M6	M6	
	80L	113	18 20 22 24 25 28 30 32 35	43.5						
	90	88	20 22 24 25 28 30 32 35 38 40 42 45 48	31	10	8	M8	M6	M6	
	90L	129	20 22 24 25 28 30 32 35 38 40 42 45 48	51.5						
	100	88	24 25 28 30 32 35 38 40 42 45 48 50 52 55 60	30						
	100L	144	24 25 28 30 32 35 38 40 42 45 48 50 52 55 60	57	14	11	M10	M8	M8	
	126	125	28 30 32 35 38 40 42 45 48 50 52 55 60 62 65	44.5						
	126L	177	28 30 32 35 38 40 42 45 48 50 52 55 60 62 65	70.5						
	144	144	32 35 38 40 42 45 48 50 52 55 60 62 65 70 75	53						
	144L	196	32 35 38 40 42 45 48 50 52 55 60 62 65 70 75	79						

①代号	②D	③L	额定扭矩 (N·m)	最大扭矩	最高转速 (r/min)	惯性力矩 (kg·m ²)	静态扭转刚度 (N·m/rad)	容许安装偏差			重量 (g)
								径向 (mm)	角向 (°)	轴向 (mm)	
CPLNSZ	56	80	50	100	15000	0.61x10 ⁻³	22x10 ³	0.02			780
	70	80	70	140	13000	0.81x10 ⁻³	30x10 ³				2902.5
	70L	105				0.93x10 ⁻³	34x10 ³				1580.5
	80	88	125	250	11000	1.32x10 ⁻³	32x10 ³	1503.5			
	80L	113				1.52x10 ⁻³	37x10 ³	1730			
	90	88	180	360	10000	2.56x10 ⁻³	68x10 ³	1	±1	2408.5	
	90L	129				2.95x10 ⁻³	78x10 ³			2300	
	100	88				3.68x10 ⁻³	79x10 ³			2471.5	
	100L	144	280	560	8000	4.23x10 ⁻³	91x10 ³	0.03		2550	
	126	125	450	900	10000	7.95x10 ⁻³	216x10 ³			5238.5	
	126L	177			7000	9.14x10 ⁻³	248x10 ³	5835			
	144	144	760	1520	8000	16.7x10 ⁻³	380x10 ³			6080.5	
	144L	196			6500	19.2x10 ⁻³	437x10 ³	9420			

△以上参数由最大孔径测得。

D1 联轴器



交货期 **12天** 发货

数量分类	标准订单	特殊订单
数量	小单	大单
交货期	1-10	11以上
	12工作日	现询

△遇到特殊期间，货期会有变更，详情请见官网通知。

相关产品推荐

		
滚珠丝杠 详情见官网	平键 ▶ P2134-2137	单轴驱动器 详情见官网



爱安特自营商城焕新登场，线上下单，疾速送达



400-6699-428



www.ant-fa.com